

***RoHS Compliant***  
**ATA Disk Chip Series**  
***Datasheet for Standard ADC 3***  
**March 21, 2011**  
**Revision 1.2**



***This Specification Describes the Features and Capabilities of  
the Standard and Industrial Temperature  
ATA Disk Chip***

***Please Contact Fortasa Memory System Sales for any  
Custom Features Required For Your Specific Application***



4151 Middlefield Road  
2<sup>nd</sup> Floor  
Palo Alto, CA 94303 USA  
888-367-8588  
[www.fortasa.com](http://www.fortasa.com)

### Features:

- **Standard ATA/IDE Bus Interface**
  - ATA command set compatible
    - ATA operating mode support for up to:
      - PIO Mode-4
      - Multiword DMA Mode-2
      - Ultra DMA Mode-5
- **Connector Type**
  - 40-pin standard female connector
- **Low power consumption (typical)**
  - Supply voltage: 3.3V & 5V
  - Active mode: 180 mA/200 mA (3.3V/5.0V)
  - Sleep mode: 4.6 mA/3.3 mA (3.3V/5.0V)
- **Performance**
  - Sustained read: up to 55 MB/sec
  - Sustained write: up to 40 MB/sec
- **Capacity**
  - <128MB – Contact Factory
  - 128, 256, 512 MB
  - 1, 2, 4, 8, GB
- **NAND flash type: SLC**
- **Superior Reliability Through Built-in Hardware ECC**
  - Corrects up to 13/24 random single-bit errors per 1024-byte sector
- **Temperature ranges**
  - Operation:
    - Standard Temperature: 0 °C to 70 °C
    - Industrial Temperature: -40 °C to 85 °C
  - Storage: -40 °C to 100 °C
- **Flash management**
  - Intelligent endurance design
    - Advanced wear-leveling algorithms*
    - S.M.A.R.T. Technology*
    - Enhanced Data Integrity*
  - Intelligent power failure recovery
  - Enhanced security level
    - Quick erase*
- **RoHS compliant**

## Table of Contents

1. General Description.....	6
2. Functional Block.....	6
3. Pin Assignments.....	7
4. Capacity Specification.....	8
4.1 Performance Specification .....	8
4.2 Environmental Specifications.....	9
5. Flash Management .....	9
5.1 Intelligent Flash Controller Features .....	9
5.1.1 Advanced wear-leveling algorithms .....	9
5.1.2 S.M.A.R.T. technology.....	9
5.1.3 Built-in hardware ECC.....	9
5.1.4 Enhanced data integrity .....	10
5.2 Intelligent Power Failure Recovery .....	10
6. Software Interface .....	11
6.1 Command Set.....	11
6.1.1 Check-Power-Mode – E5H or 98H .....	12
6.1.2 Execute-Drive-Diagnostic – 90H .....	12
6.1.3 Erase-Sector(s) – C0H.....	13
6.1.4 Flush-Cache – E7H .....	13
6.1.5 Format-Track – 50H.....	13
6.1.6 Identify-Drive – ECH .....	14
6.1.7 Idle – E3H or 97H.....	22
6.1.8 Idle-Immediate – E1H or 95H.....	22
6.1.9 Initialize-Drive-Parameters – 91H.....	22
6.1.10 NOP – 00H .....	23
6.1.11 Read-Buffer – E4H.....	23
6.1.12 Read DMA – C8H or C9H.....	23
6.1.13 Read-Multiple – C4H .....	24
6.1.14 Read Sectors – 20H or 21H.....	25
6.1.15 Read Verify Sector(s) – 40H or 41H .....	25
6.1.16 Recalibrate – 1XH.....	26

---

6.1.17 Request-sense – 03H .....	26
6.1.18 Security-Disable-Password – F6H.....	27
6.1.19 Security-Erase-Prepare – F3H.....	27
6.1.20 Security-Erase-Unit – F4H.....	28
6.1.21 Security-Freeze-Lock – F5H.....	28
6.1.22 Security-Set-Password – F1H .....	29
6.1.23 Security-Unlock – F2H.....	30
6.1.24 Seek – 7XH.....	30
6.1.25 Set-Features – EFH .....	31
6.1.26 SMART – B0H .....	32
6.1.27 Set-Multiple-Mode – C6H .....	35
6.1.28 Set-Sleep-Mode – E6H or 99H.....	36
6.1.29 Standby – E2H or 96H.....	36
6.1.30 Standby-Immediate – E0H or 94H .....	37
6.1.31 Translate-Sector – 87H.....	37
6.1.32 Write-Buffer – E8H.....	38
6.1.33 Write-DMA – CAH or CBH.....	38
6.1.34 Write-Multiple – C5H.....	39
6.1.35 Write-Multiple-Without-Erase – CDH.....	40
6.1.36 Write-Sector(s) – 30H or 31H.....	40
6.1.37 Write-Sector(s)-Without-Erase – 38H .....	41
6.1.38 Write-Verify – 3CH.....	41
<b>7. Electrical Specification.....</b>	<b>43</b>
7.1 DC Characteristics.....	44
7.2 AC Characteristics.....	45
7.2.1 I/O Input (Read) Timing Specification .....	46
7.2.2 I/O Output (Write) Timing Specification.....	47
<b>8. Physical Characteristics .....</b>	<b>48</b>
8.1 Dimensions .....	48
<b>9. Product Ordering Information .....</b>	<b>49</b>
9.1 Product Code Designations.....	49
9.2 Valid Combinations.....	50
9.2.1 Standard Temperature.....	50
9.2.2 Industrial Temperature.....	51



---

10. Revision History.....52

### 1. General Description

Fortasa's ATA-Disk Chip is a high-performance, embedded flash drive designed to replace the conventional IDE hard disk drive. The ADCs can be plugged into a standard IDE connector commonly found in desktops, IT-STB, industrial PCs and thin client systems. Fortasa's ADC SSD has a built-in microcontroller with file management firmware that communicates with the ATA standard interfaces. No additional or proprietary host software is required.

Well suited for embedded flash storage applications by offering new and expanded functionalities as well as more cost-effective designs, better performance and increased reliability, ADC is designed to work at either 5 or 3.3 Volts, supports the standard ATA/IDE protocol for up to PIO Mode-4, Multiword DMA Mode-2 and Ultra DMA Mode-5 interfaces, and uses the standard ATA driver complying with all major operating systems such as Microsoft's Windows series, Mac OS, and Unix variants.

Featuring technologies as Advanced Wear-leveling algorithms, S.M.A.R.T, Enhanced Data Integrity, Intelligent Power Failure Recovery, Secure Protection Zone and Quick Erase, Fortasa's ADC assures users of a versatile device on data storage.

### 2. Functional Block

The ATA Disk Chip includes a controller and flash media, as well as the ATA standard interface. Figure 2-1 shows the functional block diagram.

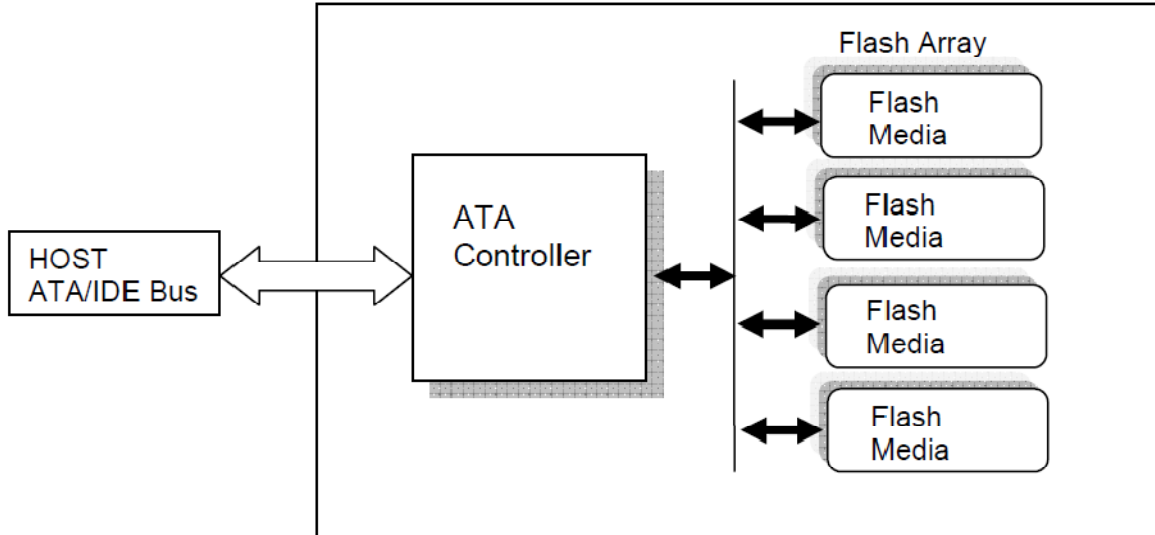
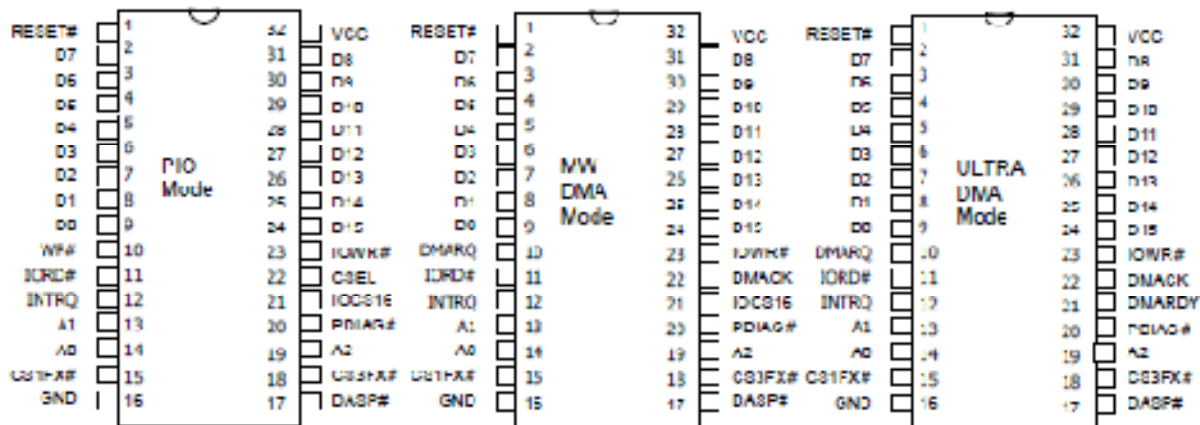

Figure 2-1: Functional block diagram

### 3. Pin Assignments

Table 3-1 lists the pin assignments with respective signal names for the 32-pin configuration. A “#” suffix indicates the active low signal. The pin type can be input, output or input/output.

**FIGURE 3-1: PIN ASSIGNMENTS FOR 32-PIN PSDIP**



**Table 3-1:** Pin assignments for the 32-pin configuration

Pin No	Signal Name	Pin Type	IO Type	Pin No	Signal Name	Pin Type	IO Type
1	RESET#	I	I2U	17	VDD	-	Power
2	D7	I/O	I1Z, O2	18	D8	I/O	I1Z, O2
3	D6	I/O	I1Z, O2	19	D9	I/O	I1Z, O2
4	D5	I/O	I1Z, O2	20	D10	I/O	I1Z, O2
5	D4	I/O	I1Z, O2	21	D11	I/O	I1Z, O2
6	D3	I/O	I1Z, O2	22	D12	I/O	I1Z, O2
7	D2	I/O	I1Z, O2	23	D13	I/O	I1Z, O2
8	D1	I/O	I1Z, O2	24	D14	I/O	I1Z, O2
9	D0	I/O	I1Z, O2	25	D15	I/O	I1Z, O2
10	WP#/DMARQ	O/I	I2U-/O1	26	IOWR#	I	I2Z
11	IORD#	I	I2Z	27	DMACK#	I	I2U-
12	INTRQ	O	O1	28	IOCS16#	O	O2
13	A1	I	I1Z	29	PDIAG#	I/O	I1U, O1
14	A0	I	I1Z	30	A2	I	I1Z
15	CS1FX#	I	I2Z	31	CS3FX#	I	I2Z
16	GND		Ground	32	DASP#	I/O	I1U, O6

## 4. Capacity Specification

Standard capacity specification of the ATA Disk Chip product are shown in Table 4-1. The table lists the specific capacity and the default numbers of heads, sectors and cylinders (CHS) for each product line.

**Table 4-1: Capacity specifications**

Capacity	Total Bytes <sup>1,2</sup>	Cylinders	Heads	Sectors	Max LBA
128MB	128,057,344	977	8	32	250,112
256MB	256,901,120	980	16	32	501,760
512MB	512,483,328	993	16	63	1,000,944
1GB	1,024,966,656	1,986	16	63	2,001,888
2GB	2,048,385,024	3,969	16	63	4,000,752
4GB	4,096,253,952	7,937	16	63	8,000,496
8GB	8,001,552,384	15,504	16	63	15,628,032
16GB	16,001,040,384	16383 <sup>3</sup>	16	63	31,252,032

1. Total bytes includes reserved system blocks.
2. Total bytes displayed varies depending on the operating system.
3. Cylinders, heads or sectors are not applicable for these capacities. Only LBA addressing applies.

***Please contact factory for any non-listed ATA Disk Chip capacity or custom CHS requirement.***

### 4.1 Performance Specification

Performances of the ATA-Disk Chip are listed in Table 4-2.

**Table 4-2: Standard Performance specifications**

Performance \ Capacity	128MB / 256 MB	2GB	4GB	8 GB / 16 GB
	512 MB / 1GB			
Sustained read (MB/s)	25	25	45	55
Sustained write (MB/s)	10	20	30	40

## 4.2 Environmental Specifications

Environmental specification of the ATA-Disk Chip series follows the MIL-STD-810F standard as shown in Table 4-3.

**Table 4-3:** Environmental specifications

Environment		Specification
Temperature	Operation	0°C to 70°C (standard); -40°C to 85°C (Industrial temperature)
	Storage	-40°C to 100°C
Vibration		Sine wave: 10~2000Hz, 15G (X, Y, Z axes)
Shock		Half sine wave, Peak acceleration 50 G, 11 ms (X, Y, Z ; All 6 axes)
Humidity		5% to 95% RH (Non-condensing)

## 5. Flash Management

The most critical attribute of an Industrial grade ATA-Disk Chip is its inherent high level of reliability. This characteristic is achieved through unique technical features of Flash Controller and specific component selection that offer higher degree of reliability compared to the consumer grade components.

### 5.1 Intelligent Flash Controller Features

#### 5.1.1 Advanced wear-leveling algorithms

All NAND flash devices are limited by a finite number of write cycles. Under a standard file system, frequent file table updates are mandatory. As a painful side effect of OS file overhead, some areas of flash address space wear out faster than others. As these certain sections get a substantially higher write occurrence the whole ATA-Disk Chip can wear out very quickly. This uneven wear would significantly reduce the lifetime of the whole device, even if majority of the Flash sectors are far from the write cycle limit. Fortasa's ATA-Disk Chip products offer advanced data wear leveling which distributes Flash writes evenly across the ATA-Disk Chip memory space. By utilizing this advanced wear leveling feature, the lifetime of the media can be significantly extended.

#### 5.1.2 S.M.A.R.T. technology

S.M.A.R.T. is an acronym for Self-Monitoring, Analysis and Reporting Technology, an open standard allowing disk drives to automatically monitor their own health and report potential problems. It protects the user from unscheduled downtime by monitoring and storing critical drive performance and calibration parameters. Ideally, this should allow taking proactive actions to prevent impending drive failure. Fortasa SMART feature adopts the conventional SMART command B0h to read data from the drive. By having the Fortasa SMART Utility running on the host, the system can monitor and analyze the ATA-Disk Chip status and determine the end of useful life for a graceful and scheduled maintenance and replacement.

#### 5.1.3 Built-in hardware ECC

The Fortasa Flash Controller uses superior BCH Error Detection Code (EDC) and Error Correction Code (ECC) algorithms which correct up to 24 random single-bit errors for each 1024-byte block of data. High performance is fulfilled through hardware-based error detection and correction.

### 5.1.4 Enhanced data integrity

The properties of NAND flash memory make it ideal for applications that require high integrity while operating in challenging environments. The integrity of data to NAND flash memory is generally maintained through ECC algorithms and bad block management. Flash controllers can support up to 8 bits ECC capability for accuracy of data transactions, and bad block management is a preventive mechanism from loss of data by retiring unusable media blocks and relocating the data to the other blocks, along with the integration of advanced wear leveling algorithms, so that the lifespan of device can be expanded.

### 5.2 Intelligent Power Failure Recovery

The Low Power Detection on the Flash controller initiates cached data saving before the power supply to the device drops too low for operation. This feature prevents the device from system crash and ensures data integrity during an unexpected brownout. This feature makes sure that there are no catastrophic failures of the ATA-Disk Chip due to system power glitches.

### 5.3 Enhanced Security Level – Special Features

Fortasa's ATA Disk Chip products offer additional security features that are not standard to the ATA interface.

#### 5.3.1 Quick erase

The ATA Disk Chip data can be rapidly and securely erased through a unique host command that could perform multiple functions:

1. Erase all data securely
2. Erase and program standard or unique pattern on top of data
3. Erase all data and FAT and FW overhead files to destroy the Chip into a completely unrecoverable state

***Please contact Fortasa Memory Systems Sales for more information about these unique features.***

## 6. Software Interface

### 6.1 Command Set

Table 6-1 summarizes the command set with the paragraphs that follow describing the individual commands and the task file for each.

**Table 6-1:** Command set

Command	Code	FR <sup>1</sup>	SC <sup>2</sup>	SN <sup>3</sup>	CY <sup>4</sup>	DH <sup>5</sup>	LBA <sup>6</sup>
Check-Power-Mode	E5H or 98H	-	-	-	-	D8	-
Execute-Drive-Diagnostic	90H	-	-	-	-	D	-
Erase-Sector(s)	C0H	-	Y	Y	Y	Y	Y
Flush-Cache	E7H	-	-	-	-	D	-
Format-Track	50H	-	Y <sup>7</sup>	-	Y	Y <sup>8</sup>	Y
Identify-Drive	ECH	-	-	-	-	D	-
Idle	E3H or 97H	-	Y	-	-	D	-
Idle-Immediate	E1H or 95H	-	-	-	-	D	-
Initialize-Drive-Parameters	91H	-	Y	-	-	Y	-
NOP	00H	-	-	-	-	D	-
Read-Buffer	E4H	-	-	-	-	D	-
Read DMA	C8H or C9H	-	Y	Y	Y	Y	Y
Read-Long-Sector	22H or 23H	-	-	Y	Y	Y	Y
Read-Multiple	C4H	-	Y	Y	Y	Y	Y
Read-Sector(s)	20H or 21H	-	Y	Y	Y	Y	Y
Read-Verify-Sector(s)	40H or 41H	-	Y	Y	Y	Y	Y
Recalibrate	1XH	-	-	-	-	D	-
Request-Sense	03H	-	-	-	-	D	-
Security-Disable-Password	F6H	-	-	-	-	D	-
Security-Erase-Prepare	F3H	-	-	-	-	D	-
Security-Erase-Unit	F4H	-	-	-	-	D	-
Security-Freeze-Lock	F5H	-	-	-	-	D	-
Security-Set-Password	F1H	-	-	-	-	D	-
Security-Unlock	F2H	-	-	-	-	D	-
Seek	7XH	-	-	Y	Y	Y	Y
Set-Features	EFH	Y	-	-	-	D	-
SMART	B0H	Y	Y	Y	Y	D	-
Set-Multiple-Mode	C6H	-	Y	-	-	D	-
Set-Sleep-Mode	E6H or 99H	-	-	-	-	D	-
Stand-By	E2H or 96H	-	-	-	-	D	-
Stand-By-Immediate	E0H or 94H	-	-	-	-	D	-
Translate Sector	87H	-	Y	Y	Y	Y	Y
Write-Buffer	E8H	-	-	-	-	D	-
Write DMA	CAH or CBH	-	Y	Y	Y	Y	Y
Write-Multiple	C5H	-	Y	Y	Y	Y	Y
Write-Multiple-Without-Erase	CDH	-	Y	Y	Y	Y	Y
Write-Sector(s)	30H or 31H	-	Y	Y	Y	Y	Y
Write-Sector(s)-Without-Erase	38H	-	Y	Y	Y	Y	Y
Write-Verify	3CH	-	Y	Y	Y	Y	Y

1. FR - Features register

2. SC - Sector Count register

# ATA Disk Chip

## FMS-FCxxxxMXXXXS-XXXX



- 3. SN - Sector Number register
- 4. CY - Cylinder registers
- 5. DH - Drive/Head register
- 6. LBA - Logical Block Address mode supported (see command descriptions for use)
- 7. Y - The register contains a valid parameter for this command
- 8. For the Drive/Head register:
  - Y means both the CFC and Head parameters are used
  - D means only the CFC parameter is valid and not the Head parameter

### 6.1.1 Check-Power-Mode - E5H or 98H

Bit ->	7	6	5	4	3	2	1	0
<b>Command (7)</b>	98H or E5H							
<b>C/D/H (6)</b>	X		Drive		X			
<b>Cyl High (5)</b>					X			
<b>Cyl Low (4)</b>					X			
<b>Sec Num (3)</b>					X			
<b>Sec Cnt (2)</b>					X			
<b>Feature (1)</b>					X			

This command checks the power mode. Because the ATA-Disk Chip can recover from sleep in 200ns, idle mode is never enabled. The ATA-Disk Chip sets BSY, sets the Sector Count register to 00H, clears BSY and generates an interrupt.

### 6.1.2 Execute-Drive-Diagnostic - 90H

Bit ->	7	6	5	4	3	2	1	0
<b>Command (7)</b>	90H							
<b>C/D/H (6)</b>	X		Drive		X			
<b>Cyl High (5)</b>					X			
<b>Cyl Low (4)</b>					X			
<b>Sec Num (3)</b>					X			
<b>Sec Cnt (2)</b>					X			
<b>Feature (1)</b>					X			

This command performs the internal diagnostic tests implemented by the ATA-Disk Chip . If the Drive bit is ignored and the diagnostic command is executed by both the Master and the Slave with the Master responding with status for both devices, the Diagnostic codes shown in Table 6-2 are returned in the Error register at the end of the command.

**Table 6-2:** Diagnostic codes

Code	Error Type
01H	No Error Detected
02H	Formatter Device Error
03H	Sector Buffer Error
04H	ECC Circuitry Error
05H	Controlling Microprocessor Error
8XH	Slave Error

# ATA Disk Chip

## FMS-FCxxxxMXXXXS-XXXX



### 6.1.3 Erase-Sector(s) – C0H

Bit ->	7	6	5	4	3	2	1	0
Command (7)	C0H							
C/D/H (6)	X	LBA	X	Drive	Head (LBA 27-24)			
Cyl High (5)	Cylinder High (LBA 23-16)							
Cyl Low (4)	Cylinder Low (LBA 15-8)							
Sec Num (3)	Sector Number (LBA 7-0)							
Sec Cnt (2)	Sector Count							
Feature (1)	X							

This command is used to pre-erase and condition data sectors in advance of a Write-Without-Erase or Write-Multiple-Without-Erase command. There is no data transfer associated with this command but a Write Fault error status can occur.

### 6.1.4 Flush-Cache – E7H

Bit ->	7	6	5	4	3	2	1	0
Command (7)	E7H							
C/D/H (6)	X		Drive		X			
Cyl High (5)	X							
Cyl Low (4)	X							
Sec Num (3)	X							
Sec Cnt (2)	X							
Feature (1)	X							

This command causes the ATA-Disk Chip to complete writing data from its cache. The ATA-Disk Chip then clears BSY and generates an interrupt.

### 6.1.5 Format-Track – 50H

Bit ->	7	6	5	4	3	2	1	0
Command (7)	50H							
C/D/H (6)	X	LBA	X	Drive	Head (LBA 27-24)			
Cyl High (5)	Cylinder High (LBA 23-16)							
Cyl Low (4)	Cylinder Low (LBA 15-8)							
Sec Num (3)	Sector Number (LBA 7-0)							
Sec Cnt (2)	Sector Count							
Feature (1)	X							

This command is accepted for host backward compatibility. The ATA-Disk Chip expects a sector buffer of data from the host to follow the command with the same protocol as the Write-Sector(s) command although the ATA-Disk Chip does not use the information in the buffer. The use of this command is not recommended.

# ATA Disk Chip

## FMS-FCxxxxMXXXXS-XXXX



### 6.1.6 Identify-Drive – ECH

Bit ->	7	6	5	4	3	2	1	0
Command (7)	E7H							
C/D/H (6)	X			Drive	X			
Cyl High (5)					X			
Cyl Low (4)					X			
Sec Num (3)					X			
Sec Cnt (2)					X			
Feature (1)					X			

The Identify-Drive command enables the host to receive parameter information from the ATA-Disk Chip. This command has the same protocol as the Read- Sector(s) command. The parameter words in the buffer have the arrangement and meanings defined in Table 6-3. All reserved bits or words are zero. Table 6-3 is the definition for each field in the Identify-Drive Information.

**Table 6-3:** Identify-Drive information (1 of 3)

Word Address	Default Value	Total Bytes	Data Field Type Information
0	044AH	2	General configuration bit-significant information
1	bbbbH <sup>2</sup>	2	Default number of cylinders
2	0000H	2	Reserved
3	bbbbH <sup>2</sup>	2	Default number of heads
4	0000H	2	Reserved
5	0200H	2	Reserved
6	bbbbH <sup>2</sup>	2	Default number of sectors per track
7-8	bbbbH <sup>2</sup>	4	Number of sectors per device (Word 7 = MSW, Word 8 = LSW)
9	xxxxH	2	Vendor Unique
10-19	ddddH <sup>4</sup>	20	Unique serial number in ASCII
20	0002H	2	Buffer type
21	xxxxH	2	Buffer size in 512 Byte increments
22	xxxxH	2	# of ECC bytes passed on Read/Write-Long-Sector Commands

# ATA Disk Chip

## FMS-FCxxxxMXXXXS-XXXX



**Table 6-3:** Identify-Drive information (2 of 3)

Word Address	Default Value	Total Bytes	Data Field Type Information
23-26	aaaaH <sup>5</sup>	8	Firmware revision in ASCII. Big Endian Byte Order in Word
27-46	ccccH <sup>6</sup>	40	User Definable Model number/name
47	8001H	2	Maximum number of sectors on Read/Write-Multiple command
48	0000H	2	Reserved
49	0B00H	2	Capabilities
50	0000H	2	Reserved
51	0200H	2	PIO data transfer cycle timing mode
52	0000H	2	Reserved
53	0007H	2	Translation parameters are valid
54	nnnnH <sup>3</sup>	2	Current numbers of cylinders
55	nnnnH <sup>3</sup>	2	Current numbers of heads
56	nnnnH <sup>3</sup>	2	Current sectors per track
57-58	nnnnH <sup>3</sup>	4	Current capacity in sectors (LBAs) (Word 57 = LSW, Word 58 = MSW)
59	010xH	2	Multiple sector setting
60-61	nnnnH <sup>3</sup>	4	Total number of sectors addressable in LBA Mode
62	0000H	2	Reserved
63	0x07H	2	DMA data transfer is supported in ATA Flash Disk Controller
64	0003H	2	Advanced PIO Transfer Mode Supported
65	0078H	2	120ns cycle time support for Multiword DMA Mode-2
66	0078H	2	120ns cycle time support for Multiword DMA Mode-2
67	0078H	2	PIO Mode-4 supported
68	0078H	2	PIO Mode-4 supported
69-79	0000H	20	Reserved
80	007EH	2	ATA/ATAPI major version number
81	0019H	2	ATA/ATAPI minor version number
82	706BH	2	Features/command sets supported
83	400CH	2	Features/command sets supported
84	4000H	2	Features/command sets supported
85-87	xxxxH	6	Features/command sets Enabled
88	xx1FH	2	Ultra DMA Mode supported and selected
89	xxxxH	2	Time required for security erase unit completion
90	xxxxH	2	Time required for enhanced security erase unit completion

**Table 6-3: Identify-Drive information (3 of 3)**

Word Address	Default Value	Total Bytes	Data Field Type Information
91-127	0000H	74	Reserved
128	xxxxH	2	Security Status
129-159	0000H	62	Vendor unique bytes
160-162	xxxxH	4	Reserved
163	xxx2H	2	Reserved
164-255	0000H	182	Reserved

1. XXXX=This field is subject to change by the host or the device
2. bbbb - default value set by controller. The selections could be user programmable.
3. n - calculated data based on product configuration
4. dddd - unique number of each device
5. aaaa - any unique firmware revision
6. cccc - default value is "xxxMB ATA-Disk Chip" where xxx is the flash drive capacity. The user has an option to change the model number during manufacturing.

### 1. Word 0: General Configuration

This field informs the host that this is a non-magnetic, hard sectored, removable storage device with a transfer rate greater than 10 MB/sec and is not MFM encoded.

### 2. Word 1: Default Number of Cylinders

This field contains the number of translated cylinders in the default translation mode. This value will be the same as the number of cylinders.

### 3. Word 3: Default Number of Heads

This field contains the number of translated heads in the default translation mode.

### 4. Word 6: Default Number of Sectors per Track

This field contains the number of sectors per track in the default translation mode.

### 5. Word 7-8: Number of Sectors

This field contains the number of sectors per ATA-Disk Chip. This double word value is also the first invalid address in LBA translation mode. This field is only required by ATA Chip feature set support.

### 6. Word 10-19: Serial Number

Unique serial number ID. The twenty bytes are a user-programmable value with a default value of spaces.

### 7. Word 20: Buffer Type

This field defines the buffer capability:

0002H: a dual ported multi-sector buffer capable of simultaneous data transfers to or from the host and the ATA-Disk Chip .

### 8. Word 23-26: Firmware Revision

This field contains the revision of the firmware for this product.

### 9. Word 27-46: Model Number

This field contains the model number for this product.

### 10. Word 47: Read-/Write-Multiple Sector Count

This field contains the maximum number of sectors that can be read or written per interrupt using the Read-Multiple or Write-Multiple commands. Only a value of '1' is supported.

### 11. Word 49: Capabilities

Bit	Function
13	Standby Timer 0: forces sleep mode when host is inactive.
11	IORDY Support 1: PIO Mode-4 is supported.
9	LBA Support 1: LBA mode addressing is supported.
8	DMA Support 1: DMA mode is supported.

### 12. Word 51: PIO Data Transfer Cycle Timing Mode

This field defines the mode for PIO data transfer. The ATA-Disk Chip supports up to PIO Mode-4

### 13. Word 53: Translation Parameters Valid

Bit	Function
0	1: Words 54-58 are valid and reflect the current number of cylinders, heads and sectors.
1	1: Words 64-70 are valid to support PIO Mode-3 and 4.
2	1: Word 88 is valid to support Ultra DMA data transfer.

### 14. Word 54-56: Current Number of Cylinders, Heads, Sectors/Track

These fields contain the current number of user addressable Cylinders, Heads, and Sectors/Track in the current translation mode.

### 15. Word 57-58: Current Capacity

This field contains the product of the current cylinders times heads times sectors.

### 16. Word 59: Multiple Sector Setting

This field contains a validity flag in the Odd Byte and the current numbers of sectors that can be transferred per interrupt for R/W Multiple in the Even Byte. The Odd Byte is always 01H which indicates that the Even Byte is always valid.

The Even Byte value depends on the value set by the Set Multiple command. The Even Byte of this word by default contains a 00H which indicates that R/W Multiple commands are not valid.

### 17. Word 60-61: Total Sectors Addressable in LBA Mode

This field contains the number of sectors addressable for the ATA-Disk Chip in LBA mode only.

### 18. Word 63: Multiword DMA Transfer

This field identifies the Multiword DMA transfer modes supported by the ATA-Disk Chip and indicates the mode that is currently selected. Only one DMA mode shall be selected at any given time.

Bit	Function
15-11	Reserved
10	Multiword DMA mode-2 selected 1: Multiword DMA mode-2 is selected and bits 8 and 9 are cleared to 0. 0: Multiword DMA mode-2 is not selected.
9	Multiword DMA mode-1 selected 1: Multiword DMA mode-1 is selected and 8 and 10 shall be cleared to 0. 0: Multiword DMA mode-1 is not selected.
8	Multiword DMA mode-0 selected 1: Multiword DMA mode-0 is selected and bits 9 and 10 are cleared to 0. 0: Multiword DMA mode-0 is not selected.
7-3	Reserved
2	Multiword DMA mode-2 supported 1: Multiword DMA mode-2 and below are supported and Bits 0 and 1 shall be set to 1.
1	Multiword DMA mode-1 supported 1: Multiword DMA mode-1 and below are supported.
0	Multiword DMA mode-0 supported 1: Multiword DMA mode-0 is supported.

### 19. Word 64: Advanced PIO Data Transfer Mode

Bit (7:0) is defined as the PIO data and register transfer supported field. If this field is supported, Bit 1 of word 53 shall be set to one. This field is bit significant. Any number of bits may be set to one in this field by the device to indicate the PIO modes the device is capable of supporting. Of these bits, bit (7:2) are Reserved for future PIO modes.

Bit	Function
0	1: PIO Mode-3 is supported.
1	1: PIO Mode-4 is supported.

### 20. Word 65: Minimum Multiword DMA Transfer Cycle Time Per Word

This field defines the minimum Multiword DMA transfer cycle time per word. This field defines, in nanoseconds, the minimum cycle time that the ATA-Disk Chip supports when performing Multiword DMA transfers on a per word basis. The ATA-Disk Chip supports up to Multiword DMA Mode-2, so this field is set to 120ns.

### 21. Word 66: Device Recommended Multiword DMA Cycle Time

This field defines the ATA-Disk Chip recommended Multiword DMA transfer cycle time. This field defines, in nanoseconds, the minimum cycle time per word during a single sector host transfer while performing a multiple sector READ DMA or WRITE DMA command for any location on the media under nominal conditions. If a host runs at a faster cycle rate by operating at a cycle time of less than this value, the ATA-Disk Chip may negate DMARQ for flow control. The rate at which DMARQ is negated could result in reduced throughput despite the faster cycle rate. Transfer at this rate does not ensure that flow control will not be used, but implies that higher performance may result. The ATA-Disk Chip supports up to Multiword DMA Mode-2, so this field is set to 120ns.

### 22. Word 67: Minimum PIO Transfer Cycle Time Without Flow Control

This field defines, in nanoseconds, the minimum cycle time that, if used by the host, the device guarantees data integrity during the transfer without utilization of IORDY flow control. If this field is supported, Bit 1 of word 53 shall be set to one. The ATA-Disk Chip minimum cycle time is 120 ns. A value of 0078H is reported.

### 23. Word 68: Minimum PIO Transfer Cycle Time with IORDY

This field defines, in nanoseconds, the minimum cycle time that the device supports while performing data transfer while utilizing IORDY flow control. If this field is supported, Bit 1 of word 53 shall be set to one. The ATA-Disk Chip minimum cycle time is 120 ns, e.g., PIO mode 4. A value of 0078H is reported.

### 24. Word 80: Major Version Number

If not 0000H or FFFFH, the device claims compliance with the major version(s) as indicated by bits (6:1) being set to one. Since ATA standards maintain downward compatibility, a device may set more than one bit. The ATA-Disk Chip supports ATA-1 to ATA-6.

### 25. Word 81: Minor Version Number

If an implementer claims that the revision of the standard they used to guide their implementation does not need to be reported or if the implementation was based upon a standard prior to the ATA-3 standard, word 81 shall be 0000H or FFFFH. A value of 0019H reported in word 81 indicates ATA/ATAPI-6 T13 1410D revision 3a guided the implementation.

### 26. Words 82-84: Features/command sets supported

Words 82, 83, and 84 indicate the features and command sets supported.

#### Word 82

Bit	Function
15	0: Obsolete
14	1: NOP command is supported
13	1: Read Buffer command is supported
12	1: Write Buffer command is supported
11	0: Obsolete
10	0: Host Protected Area feature set is not supported
9	0: Device Reset command is not supported
8	0: Service interrupt is not supported
7	0: Release interrupt is not supported
6	1: Look-ahead is supported
5	1: Write cache is supported
4	0: Packet Command feature set is not supported
3	1: Power Management feature set is supported
2	0: Removable Media feature set is not supported
1	1: Security Mode feature set is supported
0	0: SMART feature set is not supported

#### Word 83

The values in this word should not be depended on by host implementers.

Bit	Function
15	0: Provides indications that the features/command sets supported words are not valid
14	1: Provides indications that the features/command sets supported words are valid
13-9	0: Reserved
8	1: Set-Max security extension supported
7-5	0: Reserved
4	0: Removable Media Status feature set is not supported
3	1: Advanced Power Management feature set is not supported
2	1: CFA feature set is not supported
1	0: Read DMA Queued and Write DMA Queued commands are not supported
0	1: Download Microcode command is not supported

### Word 84

The values in this word should not be depended on by host implementers.

Bit	Function
-----	----------

15	0: Provides indications that the features/command sets supported words are valid
14	1: Provides indications that the features/command sets supported words are valid
13-0	0: Reserved

### 27. Words 85-87: Features/command sets enabled

Words 85, 86, and 87 indicate features/command sets enabled. The host can enable/disable the features or command set only if they are supported in Words 82-84.

#### Word 85

Bit	Function
-----	----------

15	0: Obsolete
14	0: NOP command is not enabled 1: NOP command is enabled
13	0: Read Buffer command is not enabled 1: Read Buffer command is enabled
12	0: Write Buffer command is not enabled 1: Write Buffer command is enabled
11	0: Obsolete
10	1: Host Protected Area feature set is not enabled
9	0: Device Reset command is not enabled
8	0: Service interrupt is not enabled
7	0: Release interrupt is not enabled
6	0: Look-ahead is not enabled 1: Look-ahead is enabled
5	0: Write cache is not enabled 1: Write cache is enabled
4	0: Packet Command feature set is not enabled
3	0: Power Management feature set is not enabled 1: Power Management feature set is enabled
2	0: Removable Media feature set is not enabled
1	0: Security Mode feature set has not been enabled via the Security Set Password command 1: Security Mode feature set has been enabled via the Security Set Password command
0	0: SMART feature set is not enabled

#### Word 86

Bit	Function
-----	----------

15-9	0: Reserved
8	1: Set-Max security extension enabled
7-5	0: Reserved
4	0: Removable Media Status feature set is not enabled
3	0: Advanced Power Management feature set is not enabled via the Set Features command 1: Advanced Power Management feature set is enabled via the Set Features command
2	0: CFA feature set is disabled
1	0: Read DMA Queued and Write DMA Queued commands are not enabled
0	0: Download Microcode command is not enabled

#### Word 87

The values in this word should not be depended on by host implementers.

Bit	Function
-----	----------

15	0: Provides indications that the features/command sets supported words are valid
14	1: Provides indications that the features/command sets supported words are valid
13-0	0: Reserved

**Word 88**

Bit	Function
15-13	Reserved
12	1: Ultra DMA mode-4 is selected 0: Ultra DMA mode-4 is not selected
11	1: Ultra DMA mode-3 is selected 0: Ultra DMA mode-3 is not selected
10	1: Ultra DMA mode-2 is selected 0: Ultra DMA mode-2 is not selected
9	1: Ultra DMA mode-1 is selected 0: Ultra DMA mode-1 is not selected
8	1: Ultra DMA mode-0 is selected 0: Ultra DMA mode-0 is not selected
7-5	Reserved
4	1: Ultra DMA mode-4 and below are supported
3	1: Ultra DMA mode-3 and below are supported
2	1: Ultra DMA mode-2 and below are supported
1	1: Ultra DMA mode-1 and below are supported
0	1: Ultra DMA mode-0 is supported

**28. Word 89: Time required for Security erase unit completion**

Word 89 specifies the time required for the Security Erase Unit command to complete.

Value	Time
0	Value Not Specified
1-254	(Value * 2) minutes
255	>508 minutes

**29. Word 90: Time required for Enhanced security erase unit completion**

Word 90 specifies the time required for the Enhanced Security Erase Unit command to complete.

Value	Time
0	Value Not Specified
1-254	(Value * 2) minutes
255	>508 minutes

**30. Word 128: Security Status**

Bit	Function
8	Security Level 1: Security mode is enabled and the security level is the maximum 0: and security mode is enabled, indicates that the security level is high
5	Enhanced security erase unit feature supported 1: Enhanced security erase unit feature set is supported
4	Expire 1: Security count has expired and Security Unlock and Security Erase Unit are command aborted until a power-on reset or hard reset
3	Freeze 1: Security is frozen
2	Lock 1: Security is locked

# ATA Disk Chip

## FMS-FCxxxxMXXXXS-XXXX



- 1 Enable/Disable  
1: Security is enabled  
0: Security is disabled
- 0 Capability  
1: Supports security mode feature set  
0: Does not support security mode feature set

### 6.1.7 Idle - E3H or 97H

Bit ->	7	6	5	4	3	2	1	0
Command (7)	E3H or 97H							
C/D/H (6)	X		Drive		X			
Cyl High (5)					X			
Cyl Low (4)					X			
Sec Num (3)					X			
Sec Cnt (2)	Timer Count (5msec increments)							
Feature (1)					X			

This command causes the ATA-Disk Chip to set BSY, enter the Idle Mode, clear BSY and generate an interrupt. If the sector count is non-zero, it is interpreted as a timer count with each count being 5 milliseconds and the automatic power down mode is enabled. If the sector count is zero and the automatic power down mode is also enabled, the timer count is set to 3, with each count being 5ms. Note that this time base (5msec) is different from the ATA specification.

### 6.1.8 Idle-Immediate - E1H or 95H

Bit ->	7	6	5	4	3	2	1	0
Command (7)	E1H or 95H							
C/D/H (6)	X		Drive		X			
Cyl High (5)					X			
Cyl Low (4)					X			
Sec Num (3)					X			
Sec Cnt (2)					X			
Feature (1)					X			

This command causes the ATA-Disk Chip to set BSY, enter the Idle Mode, clear BSY and generate an interrupt.

### 6.1.9 Initialize-Drive-Parameters - 91H

Bit ->	7	6	5	4	3	2	1	0
Command (7)	91H							
C/D/H (6)	X	0	X	Drive	Max Head (no. of heads-1)			
Cyl High (5)					X			
Cyl Low (4)					X			
Sec Num (3)					X			
Sec Cnt (2)	Number of Sectors							
Feature (1)					X			

This command enables the host to set the number of sectors per track and the number of heads per cylinder. Only the Sector Count and the Drive/Head registers are used by this command.

**6.1.10 NOP – 00H**

Bit ->	7	6	5	4	3	2	1	0
<b>Command (7)</b>	00H							
<b>C/D/H (6)</b>	X		Drive		X			
<b>Cyl High (5)</b>					X			
<b>Cyl Low (4)</b>					X			
<b>Sec Num (3)</b>					X			
<b>Sec Cnt (2)</b>					X			
<b>Feature (1)</b>					X			

This command always fails with the ATA-Disk Chip returning command aborted.

**6.1.11 Read-Buffer – E4H**

Bit ->	7	6	5	4	3	2	1	0
<b>Command (7)</b>	E4H							
<b>C/D/H (6)</b>	X		Drive		X			
<b>Cyl High (5)</b>					X			
<b>Cyl Low (4)</b>					X			
<b>Sec Num (3)</b>					X			
<b>Sec Cnt (2)</b>					X			
<b>Feature (1)</b>					X			

The Read Buffer command enables the host to read the current contents of the ATA-Disk Chip (ADC)'s sector buffer. This command has the same protocol as the Read Sector(s) command.

**6.1.12 Read DMA – C8H or C9H**

Bit ->	7	6	5	4	3	2	1	0
<b>Command (7)</b>	C8H or C9H							
<b>C/D/H (6)</b>	1	LBA	1	Drive	Head (LBA 27-24)			
<b>Cyl High (5)</b>	Cylinder High (LBA 23-16)							
<b>Cyl Low (4)</b>	Cylinder Low (LBA 15-8)							
<b>Sec Num (3)</b>	Sector Number (LBA 7-0)							
<b>Sec Cnt (2)</b>	Sector Count							
<b>Feature (1)</b>	X							

This command executes in a similar manner to the READ SECTOR (S) command except for the following:

- The host initializes the DMA channel prior to issuing the command;
- Data transfers are qualified by DMARQ and are performed by the DMA channel;
- The ATA-Disk Chip issues only one interrupt per command to indicate that data transfer has terminated and status is available.

During the DMA transfer phase of a READ DMA command, the ATA-Disk Chip shall provide status of the BSY bit or the DRQ bit until the command is completed. At command completion, the command block registers contain the cylinder, head and sector number (LBA) of the last sector read.

If an error occurs, the read terminates at the sector where the error occurred. The flawed data is pending in the sector buffer. Subsequent sectors are transferred only if the error was a correctable data error. All other errors cause Read-DMA to stop after transfer of the sector that contained the error.

For Ultra-DMA mode, if a CRC error is detected during transfer, the ICRC and ABRT bits of the Error register are set at the end of the command.

### 6.1.13 Read-Multiple – C4H

Bit ->	7	6	5	4	3	2	1	0
<b>Command (7)</b>	C4H							
<b>C/D/H (6)</b>	X	LBA	X	Drive	Head (LBA 27-24)			
<b>Cyl High (5)</b>	Cylinder High (LBA 23-16)							
<b>Cyl Low (4)</b>	Cylinder Low (LBA 15-8)							
<b>Sec Num (3)</b>	Sector Number (LBA 7-0)							
<b>Sec Cnt (2)</b>	Sector Count							
<b>Feature (1)</b>	X							

The Read- Multiple command is similar to the Read- Sector(s) command. Interrupts are not generated on every sector, but on the transfer of a block which contains the number of sectors defined by a Set-Multiple command.

Command execution is identical to the Read- Sectors operation except that the numbers of sectors defined by a Set-Multiple command are transferred without intervening interrupts. DRQ qualification of the transfer is required only at the start of the data block, not on each sector.

The block count of sectors to be transferred without intervening interrupts is programmed by the Set-Multiple Mode command, which must be executed prior to the Read-Multiple command. When the Read-Multiple command is issued, the Sector Count register contains the number of sectors (not the number of blocks or the block count) requested. If the number of requested sectors is not evenly divisible by the block count, as many full blocks as possible are transferred, followed by a final, partial block transfer.

The partial block transfer is for  $n$  sectors, where  $n = \text{remainder}(\text{sector count}/\text{block count})$ . If the Read-Multiple command is attempted before the Set-Multiple Mode command has been executed or when Read-Multiple commands are disabled, the Read-Multiple operation is rejected with an Aborted Command error. Disk errors encountered during Read-Multiple commands are posted at the beginning of the block or partial block transfer, but DRQ is still set and the data transfer will take place as it normally would, including transfer of corrupted data, if any.

Interrupts are generated when DRQ is set at the beginning of each block or partial block. The error reporting is the same as that on a Read-Sector(s) Command. This command reads from 1 to 256 sectors as specified in the Sector Count register. A sector counts of 0 requests 256 sectors. The transfer begins at the sector specified in the Sector Number register.

At command completion, the Command Block registers contain the cylinder, head and sector number of the last sector read. If an error occurs, the read terminates at the sector where the error occurred. The Command Block registers contain the cylinder, head and sector number of the sector where the error occurred. The flawed data is pending in the sector buffer.

Subsequent blocks or partial blocks are transferred only if the error was a correctable data error. All other errors cause the command to stop after transfer of the block which contained the error.

**6.1.14 Read Sectors – 20H or 21H**

Bit ->	7	6	5	4	3	2	1	0
<b>Command (7)</b>	20H or 21H							
<b>C/D/H (6)</b>	X	LBA	X	Drive	Head (LBA 27-24)			
<b>Cyl High (5)</b>	Cylinder High (LBA 23-16)							
<b>Cyl Low (4)</b>	Cylinder Low (LBA 15-8)							
<b>Sec Num (3)</b>	Sector Number (LBA 7-0)							
<b>Sec Cnt (2)</b>	Sector Count							
<b>Feature (1)</b>	X							

This command reads from 1 to 256 sectors as specified in the Sector Count register. A sectors count of 0 requests 256 sectors. The transfer begins at the sector specified in the Sector Number register. When this command is issued and after each sector of data (except the last one) has been read by the host, the ATA-Disk Chip sets BSY, puts the sector of data in the buffer, sets DRQ, clears BSY, and generates an interrupt. The host then reads the 512 bytes of data from the buffer.

At command completion, the Command Block registers contain the cylinder, head and sector number of the last sector read. If an error occurs, the read terminates at the sector where the error occurred. The Command Block registers contain the cylinder, head, and sector number of the sector where the error occurred. The flawed data is pending in the sector buffer.

**6.1.15 Read Verify Sector(s) – 40H or 41H**

Bit ->	7	6	5	4	3	2	1	0
<b>Command (7)</b>	40H or 41H							
<b>C/D/H (6)</b>	X	LBA	X	Drive	Head (LBA 27-24)			
<b>Cyl High (5)</b>	Cylinder High (LBA 23-16)							
<b>Cyl Low (4)</b>	Cylinder Low (LBA 15-8)							
<b>Sec Num (3)</b>	Sector Number (LBA 7-0)							
<b>Sec Cnt (2)</b>	Sector Count							
<b>Feature (1)</b>	X							

This command is identical to the Read- Sectors command, except that DRQ is never set and no data is transferred to the host. When the command is accepted, the ATA-Disk Chip sets BSY.

When the requested sectors have been verified, the ATA-Disk Chip clears BSY and generates an interrupt. Upon command completion, the Command Block registers contain the cylinder, head, and sector number of the last sector verified.

If an error occurs, the Verify terminates at the sector where the error occurs. The Command Block registers contain the cylinder, head and sector number of the sector where the error occurred. The Sector Count register contains the number of sectors not yet verified.

**6.1.16 Recalibrate – 1XH**

Bit ->	7	6	5	4	3	2	1	0
<b>Command (7)</b>	1XH							
<b>C/D/H (6)</b>	X	LBA	X	Drive			X	
<b>Cyl High (5)</b>	X							
<b>Cyl Low (4)</b>	X							
<b>Sec Num (3)</b>	X							
<b>Sec Cnt (2)</b>	X							
<b>Feature (1)</b>	X							

This command is effectively a no operation command to the ATA-Disk Chip and is provided for compatibility purposes.

**6.1.17 Request-sense – 03H**

Bit ->	7	6	5	4	3	2	1	0
<b>Command (7)</b>	03H							
<b>C/D/H (6)</b>		X		Drive			X	
<b>Cyl High (5)</b>	X							
<b>Cyl Low (4)</b>	X							
<b>Sec Num (3)</b>	X							
<b>Sec Cnt (2)</b>	X							
<b>Feature (1)</b>	X							

This command requests extended error information for the previous command. Table 6-4 defines the valid extended error codes for the ATA-Disk Chip. The extended error code is returned to the host in the Error register.

**Table 6-4:** Extended Error Codes

Extended Error Code	Description
00H	No Error Detected
01H	Self Test OK (No Error)
09H	Miscellaneous Error
20H	Invalid Command
21H	Invalid Address (Requested Head or Sector Invalid)
2FH	Address Overflow (Address Too Large)
35H, 36H	Supply or generated Voltage Out of Tolerance
11H	Uncorrectable ECC Error
18H	Corrected ECC Error
05H, 30-34H, 37H, 3EH	Self Test or Diagnostic Failed
10H, 14H	ID Not Found
3AH	Spare Sectors Exhausted
1FH	Data Transfer Error / Aborted Command
0CH, 38H, 3BH, 3CH, 3FH	Corrupted Media Format
03H	Write / Erase Failed
22H	Power Level 1 Disabled

**6.1.18 Security-Disable-Password – F6H**

Bit ->	7	6	5	4	3	2	1	0
<b>Command (7)</b>	F6H							
<b>C/D/H (6)</b>	X			Drive	X			
<b>Cyl High (5)</b>					X			
<b>Cyl Low (4)</b>					X			
<b>Sec Num (3)</b>					X			
<b>Sec Cnt (2)</b>					Config			
<b>Feature (1)</b>					Feature			

This command requests a transfer of a single sector of data from the host. Table 6-5 defines the content of this sector of information. If the password selected by Word 0 matches the password previously saved by the device, the device disables the lock mode. This command does not change the Master password that may be reactivated later by setting a User password.

**Table 6-5:** Security password data content

Word	Content
0	Control word: Bit 0: Identifier 0: Compare user password 1: Compare master password Bit 1-15: Reserved
1-16	Password (32 bytes)
17-256	Reserved

**6.1.19 Security-Erase-Prepare – F3H**

Bit ->	7	6	5	4	3	2	1	0
<b>Command (7)</b>	F3H							
<b>C/D/H (6)</b>	X			Drive	X			
<b>Cyl High (5)</b>					X			
<b>Cyl Low (4)</b>					X			
<b>Sec Num (3)</b>					X			
<b>Sec Cnt (2)</b>					Config			
<b>Feature (1)</b>					Feature			

This command is issued immediately before the Security-Erase-Unit command to enable device erasing and unlocking. This command prevents accidental erasure of the data in the flash media.

### 6.1.20 Security-Erase-Unit - F4H

Bit ->	7	6	5	4	3	2	1	0
<b>Command (7)</b>	F4H							
<b>C/D/H (6)</b>	X		Drive		X			
<b>Cyl High (5)</b>					X			
<b>Cyl Low (4)</b>					X			
<b>Sec Num (3)</b>					X			
<b>Sec Cnt (2)</b>					Config			
<b>Feature (1)</b>					Feature			

This command requests transfer of a single sector of data from the host. Table 6-5 defines the content of this sector of information. If the password does not match the password previously saved by the ATA-Disk Chip, the ATA-Disk Chip rejects the command with command aborted. The Security-Erase-Prepare command should be completed immediately prior to the Security-Erase-Unit command. If the ATA-Disk Chip receives a Security-Erase-Unit command without an immediately prior Security-Erase-Prepare command, the ATA-Disk Chip aborts the Security- Erase-Unit command.

### 6.1.21 Security-Freeze-Lock - F5H

Bit ->	7	6	5	4	3	2	1	0
<b>Command (7)</b>	F5H							
<b>C/D/H (6)</b>	X		Drive		X			
<b>Cyl High (5)</b>					X			
<b>Cyl Low (4)</b>					X			
<b>Sec Num (3)</b>					X			
<b>Sec Cnt (2)</b>					Config			
<b>Feature (1)</b>					Feature			

The Security-Freeze-Lock command sets the ATA-Disk Chip to Frozen mode. After command completion, any other commands that update the ATA-Disk Chip Lock mode are rejected. Frozen mode is disabled by power off or hardware reset. If Security-Freeze-Lock is issued when the ATA-Disk Chip is in Frozen mode, the command executes and the ATA-Disk Chip remains in Frozen mode. After command completion, the Sector Count Register shall be set to 0. Commands disabled by Security- Freeze-Lock are:

- Security-Set-Password
- Security-Unlock
- Security-Disable-Password
- Security-Erase-Unit

If security mode feature set is not supported, this command shall be handled as Wear- Level command.

**6.1.22 Security-Set-Password – F1H**

Bit ->	7	6	5	4	3	2	1	0
<b>Command (7)</b>	F1H							
<b>C/D/H (6)</b>	X		Drive		X			
<b>Cyl High (5)</b>					X			
<b>Cyl Low (4)</b>					X			
<b>Sec Num (3)</b>					X			
<b>Sec Cnt (2)</b>					Config			
<b>Feature (1)</b>					Feature			

This command requests a transfer of a single sector of data from the host. Table 6-6 defines the content of the sector of information. The data transferred controls the function of this command.

**Table 6-6:** Security password data content

Word	Content
0	Control word: Bit 0: Identifier 0: Compare user password 1: Compare master password Bit 1-15: Reserved
1-16	Password (32 bytes)
17-256	Reserved

**Table 6-7:** Identifier and security level bit interaction

Identifier	Level	Command Result
User	High	The password supplied with the command shall be saved as the new User password. The lock mode shall be enabled from the next power-on or hardware reset. The ATA-Disk Chip shall then be unlocked by either the User password or the previously set Master password.
User	Maximum	The password supplied with the command shall be saved as the new user password. The lock mode shall be enabled from the next power-on reset or hardware reset. The ATA-Disk Chip shall then be unlocked by only the User password. The Master password previously set is still stored in the ATA-Disk Chip shall not be used to unlock the ATA-Disk Chip.
User	High or Maximum	This combination shall set a Master password but shall not enable or disable the Lock mode. The security level is not changed.

**6.1.23 Security-Unlock – F2H**

Bit ->	7	6	5	4	3	2	1	0
<b>Command (7)</b>	F2H							
<b>C/D/H (6)</b>		X		Drive			X	
<b>Cyl High (5)</b>	X							
<b>Cyl Low (4)</b>	X							
<b>Sec Num (3)</b>	X							
<b>Sec Cnt (2)</b>	Config							
<b>Feature (1)</b>	Feature							

This command requests transfer of a single sector of data from the host. Table 6-7 defines the content of this sector of information. If the identifier bit is set to Master and the device is in high security level, then the password supplied shall be compared with the stored Master password. If the device is in the maximum security level, then the unlock command shall be rejected. If the identifier bit is set to user, then the device compares the supplied password with the stored User password. If the password compare fails then the device returns command aborted to the host and decrements the unlock counter. This counter is initially set to five and is decremented for each password mismatch when Security-Unlock is issued and the device is locked. Once this counter reaches zero, the Security-Unlock and Security-Erase-Unit commands are command aborted until after a power-on reset or a hardware reset is received. Security-Unlock commands issued when the device is unlocked have no effect on the unlock counter.

**6.1.24 Seek – 7XH**

Bit ->	7	6	5	4	3	2	1	0
<b>Command (7)</b>	7XH							
<b>C/D/H (6)</b>	X	LBA	X	Drive	Head (LBA 27-24)			
<b>Cyl High (5)</b>	Cylinder High (LBA 23-16)							
<b>Cyl Low (4)</b>	Cylinder Low (LBA 15-8)							
<b>Sec Num (3)</b>	Sector Number (LBA 7-0)							
<b>Sec Cnt (2)</b>	Sector Count							
<b>Feature (1)</b>	X							

This command is effectively a NOP command to the ATA-Disk Chip although it does perform a range check of cylinder and head or LBA address and returns an error if the address is out of range.

### 6.1.25 Set-Features – EFH

Bit ->	7	6	5	4	3	2	1	0
Command (7)	EFH							
C/D/H (6)	X		Drive		X			
Cyl High (5)					X			
Cyl Low (4)					X			
Sec Num (3)					X			
Sec Cnt (2)					Config			
Feature (1)					Feature			

This command is used by the host to establish or select certain features. Table 6-5 defines all features that are supported.

Feature	Operation
01H	Enable 8-bit data transfers.
03H	Set transfer mode based on value in Sector Count register. Table 11-6 defines the values.
55H	Disable Read Look Ahead.
66H	Disable Power on Reset (POR) establishment of defaults at software Reset.
69H	NOP - Accepted for backward compatibility.
81H	Disable 8-bit data transfer.
96H	NOP - Accepted for backward compatibility.
97H	Accepted for backward compatibility. Use of this Feature is not recommended.
9AH	NOP - accepted for compatibility.
BBH	4 Bytes of data apply on Read/Write-Long-Sector commands.
AAH	Enable Read Look Ahead.
CCH	Enable Power on Reset (POR) establishment of defaults at software Reset.

Features 01H and 81H are used to enable and clear 8-bit data transfer mode. If the 01H feature command is issued all data transfers will occur on the low order D<sub>7</sub>-D<sub>0</sub> data bus and the IOCS16# signal will not be asserted for data register accesses.

Features 02H and 82H allow the host to enable or disable write cache in the ATA-Disk Chip that implements write cache. When the subcommand Disable-Write-Cache is issued, the ATA-Disk Chip should initiate the sequence to flush cache to non-volatile memory before command completion.

Feature 03H allows the host to select the transfer mode by specifying a value in the Sector Count register. The upper 5 bits define the type of transfer and the low order 3 bits encode the mode value. One PIO mode is selected at all times. The host may change the selected modes by the Set-Features command.

Feature 55H is the default feature for the ATA-Disk Chip. Therefore, the host does not have to issue Set-Features command with this feature unless it is necessary for compatibility reasons.

Features 66H and CCH can be used to enable and disable whether the Power-on Reset (POR) Defaults will be set when a software reset occurs.

**Table 6-6: Transfer mode values**

Mode	Bits [7:3]	Bits [2:0]
PIO default mode	00000b	000b
PIO default mode, disable IORDY	00000b	001b
PIO flow control transfer mode	00001b	mode <sup>1</sup>
Multiword DMA mode	00100b	mode <sup>1</sup>
Ultra DMA mode	01000b	mode <sup>1</sup>
Reserved	Other	N/A

1. Mode = transfer mode number, all other values are not valid

### 6.1.26 SMART – B0H

Smart Command signature is defined as cylinder being C2H to F4H. The feature register will indicate the subcommand as listed below.

#### 6.1.26.1 SMART Return Status – DAH

Bit ->	7	6	5	4	3	2	1	0
<b>Command (7)</b>	B0H							
<b>C/D/H (6)</b>	X		Drive		X			
<b>Cyl High (5)</b>	C2H							
<b>Cyl Low (4)</b>	4FH							
<b>Sec Num (3)</b>	X							
<b>Sec Cnt (2)</b>	X							
<b>Feature (1)</b>	DAH							

This Command is used to communicate the reliability status of the device to the host at the host's request. If the device has not detected a threshold exceeded condition, the device sets the LBA Mid register to 4FH and the LBA High register to C2H. If the device has detected a threshold exceeded condition, the device sets the LBA Mid register to F4H and the LBA High register to 2CH. In the current implementation, the only threshold checked is that if a fatal error has occurred.

#### 6.1.26.2 SMART Enable/Disable Attribute Autosave – D2H

Bit ->	7	6	5	4	3	2	1	0
<b>Command (7)</b>	B0H							
<b>C/D/H (6)</b>	X		Drive		X			
<b>Cyl High (5)</b>	C2H							
<b>Cyl Low (4)</b>	4FH							
<b>Sec Num (3)</b>	X							
<b>Sec Cnt (2)</b>	00H or F1H							
<b>Feature (1)</b>	D2H							

This Command enables or disables the optional attribute autosave feature of the device. A value of 00H in the Sec Cnt register will disable the autosave feature. A value of F1H in the Sec Cnt register will enable the autosave feature. Currently, no action is generated by this command since there is no online collection of data.

**6.1.26.3 SMART Enable Operations – D8H**

Bit ->	7	6	5	4	3	2	1	0
<b>Command (7)</b>	B0H							
<b>C/D/H (6)</b>	X		Drive		X			
<b>Cyl High (5)</b>	C2H							
<b>Cyl Low (4)</b>	4FH							
<b>Sec Num (3)</b>	X							
<b>Sec Cnt (2)</b>	X							
<b>Feature (1)</b>	D8H							

This Command enables access to all SMART capabilities within the device. Prior to receipt of this command, SMART data is collected but not accessible via SMART. The state of SMART (either enabled or disabled) shall be preserved by the device across power cycles. Once enabled, the receipt of subsequent SMART ENABLE OPERATIONS commands shall not affect any SMART data or functions.

**6.1.26.4 SMART Disable Operations – D9H**

Bit ->	7	6	5	4	3	2	1	0
<b>Command (7)</b>	B0H							
<b>C/D/H (6)</b>	X		Drive		X			
<b>Cyl High (5)</b>	C2H							
<b>Cyl Low (4)</b>	4FH							
<b>Sec Num (3)</b>	X							
<b>Sec Cnt (2)</b>	X							
<b>Feature (1)</b>	D9H							

This Command disables access to SMART data via SMART commands. After receipt of this command the device shall disable all SMART operations. However SMART data shall continue to be collected and accessible when SMART is next enabled. The state of SMART (either enabled or disabled) shall be preserved by the device across power cycles. After receipt of this command by the device, all other SMART commands, including SMART DISABLE OPERATIONS commands, with the exception of SMART ENABLE OPERATIONS, are disabled and invalid, and the commands shall aborted by the device.

# ATA Disk Chip

## FMS-FCxxxxMXXXXS-XXXX



### 6.1.26.5 SMART Execute Offline – D4H

Bit ->	7	6	5	4	3	2	1	0
<b>Command (7)</b>	B0H							
<b>C/D/H (6)</b>	X		Drive		X			
<b>Cyl High (5)</b>	C2H							
<b>Cyl Low (4)</b>	4FH							
<b>Sec Num (3)</b>	Subcommand Specific							
<b>Sec Cnt (2)</b>	X							
<b>Feature (1)</b>	D4H							

This Command causes the device to immediately initiate the optional set of activities that collect SMART data in an off-line mode and the save this data to the device's memory. This data is not retained across resets and a new command must be executed to recollect data. The SMART data collected is determined by the subcommand specified in the Sec Num register. All subcommands other than listed below will be aborted. Valid subcommands will be executed in captive mode and the device will set BSY bit until command is completed. The collected data should be read by a subsequent SMART Read Data (D0H) command.

SMART EXECUTE OFF-LINE Sector Number register values (sub-command specific)

Subcommand	Collected Data
0-201	Reserved
202 (0xCA)	Bad block count (captive)
203 (0xCB)	Group free block count (captive)
204 (0xCC)	Group average age (captive)
205 (0xCD)	Group maximum age (captive)
206 (0xCE)	Group minimum age (captive)
207 (0xCF)	Group wear swap count (captive)
208 (0xD0)	Group retention swap count (captive)
209 (0xD1)	Group total block erase count (captive)
210-255	Reserved

# ATA Disk Chip

## FMS-FCxxxxMXXXXS-XXXX



### 6.1.26.6 SMART Read Data – D0H

Bit ->	7	6	5	4	3	2	1	0
Command (7)	B0H							
C/D/H (6)	X		Drive		X			
Cyl High (5)	C2H							
Cyl Low (4)	4FH							
Sec Num (3)	X							
Sec Cnt (2)	X							
Feature (1)	D0H							

This Command returns the Device SMART data structure to the host. This command must be preceded by the SMART Execute Offline command with an appropriate subcommand listed above. The returned data will depend on the requested subcommand.

All returned data comply with the SMART data structure as specified in the ATA spec. Bytes 0 to 361 of the structure returns SST specific data that depends of the requested subcommand. Bytes 362 to 385 are standard values as defined in the ATA spec. bytes 386 to 510 returns SST specific data common to all subcommands. Byte 511 is the 2's complement checksum of all bytes in the data structure.

### Offline Data Collection Status (byte 362)

The offline data collection status byte indicates whether SMART data collection was successful or not. The host should check this value in the returned data structure before proceeding with interpretation of vendor specific data bytes. The follow are possible status values.

Value	Definition
00H	Offline data collection activity was never started.
02H	Offline data collection activity was completed without error.
04H	Offline data collection activity was suspended host.
05H	Offline data collection activity was aborted by host.
06H	Offline data collection activity was aborted by device.

### 6.1.27 Set-Multiple-Mode – C6H

Bit ->	7	6	5	4	3	2	1	0
Command (7)	C6H							
C/D/H (6)	X		Drive		X			
Cyl High (5)	X							
Cyl Low (4)	X							
Sec Num (3)	X							
Sec Cnt (2)	Sector Count							
Feature (1)	X							

This command enables the ATA-Disk Chip to perform Read and Write Multiple operations and establishes the block count for these commands. The Sector Count register is loaded with the number of sectors per block. Upon receipt of the command, the ATA-Disk Chip sets BSY to 1 and checks the Sector Count register.

If the Sector Count register contains a valid value and the block count is supported, the value is loaded for all subsequent Read-Multiple and Write-Multiple commands and execution of those commands is enabled. If a block count is not supported, an Aborted command error is posted, and Read- Multiple and Write- Multiple commands are disabled. If the Sector Count registers contains 0 when the command is issued, Read and Write- Multiple commands are disabled. At power-on, or after a hardware or (unless disabled by a Set-Feature command) software reset, the default mode is Read and Write-Multiple disabled.

### 6.1.28 Set-Sleep-Mode – E6H or 99H

Bit ->	7	6	5	4	3	2	1	0
<b>Command (7)</b>	E6H or 99H							
<b>C/D/H (6)</b>	X		Drive		X			
<b>Cyl High (5)</b>					X			
<b>Cyl Low (4)</b>					X			
<b>Sec Num (3)</b>					X			
<b>Sec Cnt (2)</b>					X			
<b>Feature (1)</b>					X			

This command causes the ATA-Disk Chip to set BSY, enter the Sleep mode, clear BSY and generate an interrupt. Recovery from sleep mode is accomplished by simply issuing another command (a reset is permitted but not required). Sleep mode is also entered when internal timers expire so the host does not need to issue this command except when it wishes to enter Sleep mode immediately. The default value for the timer is 15 milliseconds.

### 6.1.29 Standby – E2H or 96H

Bit ->	7	6	5	4	3	2	1	0
<b>Command (7)</b>	E2H or 96H							
<b>C/D/H (6)</b>	X		Drive		X			
<b>Cyl High (5)</b>					X			
<b>Cyl Low (4)</b>					X			
<b>Sec Num (3)</b>					X			
<b>Sec Cnt (2)</b>					X			
<b>Feature (1)</b>					X			

This command causes the ATA-Disk Chip to set BSY, enter the Sleep mode (which corresponds to the ATA “Standby” Mode), clear BSY and return the interrupt immediately. Recovery from Sleep mode is accomplished by simply issuing another command (a reset is not required).

**6.1.30 Standby-Immediate – E0H or 94H**

Bit ->	7	6	5	4	3	2	1	0
<b>Command (7)</b>	E0H or 94H							
<b>C/D/H (6)</b>		X		Drive			X	
<b>Cyl High (5)</b>					X			
<b>Cyl Low (4)</b>					X			
<b>Sec Num (3)</b>					X			
<b>Sec Cnt (2)</b>					X			
<b>Feature (1)</b>					X			

This command causes the ATA-Disk Chip to set BSY, enter the Sleep mode (which corresponds to the ATA “Standby” Mode), clear BSY and return the interrupt immediately. Recovery from Sleep mode is accomplished by simply issuing another command (a reset is not required).

**6.1.31 Translate-Sector – 87H**

Bit ->	7	6	5	4	3	2	1	0
<b>Command (7)</b>	87H							
<b>C/D/H (6)</b>	1	LBA	1	Drive		Head (LBA 27-24)		
<b>Cyl High (5)</b>	Cylinder High (LBA 23-16)							
<b>Cyl Low (4)</b>	Cylinder Low (LBA 15-8)							
<b>Sec Num (3)</b>	Sector Number (LBA 7-0)							
<b>Sec Cnt (2)</b>					X			
<b>Feature (1)</b>					X			

This command allows the host a method of determining the exact number of times a user sector has been erased and programmed. The controller responds with a 512 Byte buffer of information containing the desired cylinder, head, and sector, including its logical address, and the Hot Count, if available, for that sector. Table 6-7 represents the information in the buffer. Please note that this command is unique to the ATA-Disk Chip.

**Table 6-7: Translate-Sector Information**

Address	Information
00H-01H	Cylinder MSB (00), Cylinder LSB (01)
02H	Head
03H	Sector
04H-06H	LBA MSB (04) - LSB (06)
07H-12H	Reserved
13H	Erased flag (FFh) = Erased; 00h = Not erased
14H-17H	Reserved
18H-1AH	Hot Count MSB (18) - LSB (1A) <sup>1</sup>
1BH-1FFH	Reserved

1. A value of 0 indicates Hot Count is not supported.

**6.1.32 Write-Buffer - E8H**

Bit ->	7	6	5	4	3	2	1	0
<b>Command (7)</b>	E8H							
<b>C/D/H (6)</b>		X		Drive			X	
<b>Cyl High (5)</b>					X			
<b>Cyl Low (4)</b>					X			
<b>Sec Num (3)</b>					X			
<b>Sec Cnt (2)</b>					X			
<b>Feature (1)</b>					X			

The Write-Buffer command enables the host to overwrite contents of the ATA-Disk Chip sector buffer with any data pattern desired. This command has the same protocol as the Write-Sector(s) command and transfers 512 bytes.

**6.1.33 Write-DMA - CAH or CBH**

Bit ->	7	6	5	4	3	2	1	0
<b>Command (7)</b>	CAH or CBH							
<b>C/D/H (6)</b>	1	LBA	1	Drive		Head (LBA 27-24)		
<b>Cyl High (5)</b>	Cylinder High (LBA 23-16)							
<b>Cyl Low (4)</b>	Cylinder Low (LBA 15-8)							
<b>Sec Num (3)</b>	Sector Number (LBA 7-0)							
<b>Sec Cnt (2)</b>	Sector Count							
<b>Feature (1)</b>	X							

This command executes in a similar manner to Write-RITE Sector(s) except for the following:

- The host initializes the DMA channel prior to issuing the command
- Data transfers are qualified by DMARQ and are performed by the DMA channel
- The ATA-Disk Chip issues only one interrupt per command to indicate that data transfer has terminated and status is available.

During the execution of a Write-RITE DMA command, the ATA-Disk Chip shall provide status of the BSY bit or the DRQ bit until the command is completed. At command completion, the command block registers contain the cylinder, head and sector number (LBA) of the last sector read.

If an error occurs after the attempted write of a transferred sector, the command is terminated and subsequent blocks are not transferred. The command block registers contain the cylinder, head and sector number of the sector where the error occurred and the Sector Count register contains the residual number of sectors for successful completion of the command.

For Ultra-DMA mode, if a CRC error is detected during transfer, the ICRC and ABRT bits of the Error register are set at the end of the command.

**6.1.34 Write-Multiple - C5H**

Bit ->	7	6	5	4	3	2	1	0
<b>Command (7)</b>	CAH or CBH							
<b>C/D/H (6)</b>	1	LBA	1	Drive	Head (LBA 27-24)			
<b>Cyl High (5)</b>	Cylinder High (LBA 23-16)							
<b>Cyl Low (4)</b>	Cylinder Low (LBA 15-8)							
<b>Sec Num (3)</b>	Sector Number (LBA 7-0)							
<b>Sec Cnt (2)</b>	Sector Count							
<b>Feature (1)</b>	X							

**Note:** The current revision of the ATA-Disk Chip can support up to a block count of 1 as indicated in the Identify Drive Command information.

This command is similar to the Write-Sectors command. The ATA-Disk Chip sets BSY within 400 ns of accepting the command. Interrupts are not presented on each sector but on the transfer of a block which contains the number of sectors defined by Set-Multiple. Command execution is identical to the Write-Sectors operation except that the number of sectors defined by the Set-Multiple command is transferred without intervening interrupts.

DRQ qualification of the transfer is required only at the start of the data block, not on each sector. The block count of sectors to be transferred without intervening interrupts is programmed by the Set-Multiple Mode command, which must be executed prior to the Write-Multiple command.

When the Write-Multiple command is issued, the Sector Count register contains the number of sectors (not the number of blocks or the block count) requested. If the number of requested sectors is not evenly divisible by the sector/block, as many full blocks as possible are transferred, followed by a final, partial block transfer. The partial block transfer is for n sectors, where:  $n = \text{remainder}(\text{sector count}/\text{block count})$ . If the Write-Multiple command is attempted before the Set-Multiple-Mode command has been executed or when Write-Multiple commands are disabled, the Write-Multiple operation will be rejected with an aborted command error.

Errors encountered during Write-Multiple commands are posted after the attempted writes of the block or partial block transferred. The Write command ends with the sector in error, even if it is in the middle of a block. Subsequent blocks are not transferred in the event of an error. Interrupts are generated when DRQ is set at the beginning of each block or partial block.

The Command Block registers contain the cylinder, head and sector number of the sector where the error occurred and the Sector Count register contains the residual number of sectors that need to be transferred for successful completion of the command, e.g. each block has 4 sectors, a request for 8 sectors is issued and an error occurs on the third sector. The Sector Count register contains 6 and the address is that of the third sector.

**6.1.35 Write-Multiple-Without-Erase – CDH**

Bit ->	7	6	5	4	3	2	1	0
<b>Command (7)</b>	CDH							
<b>C/D/H (6)</b>	1	LBA	1	Drive	Head (LBA 27-24)			
<b>Cyl High (5)</b>	Cylinder High (LBA 23-16)							
<b>Cyl Low (4)</b>	Cylinder Low (LBA 15-8)							
<b>Sec Num (3)</b>	Sector Number (LBA 7-0)							
<b>Sec Cnt (2)</b>	Sector Count							
<b>Feature (1)</b>	X							

This command is similar to the Write-Multiple command with the exception that an implied Erase before Write operation is not performed. The sectors should be pre-erased with the Erase-Sector(s) command before this command is issued. If the sectors are not pre-erased with the Erase-Sector(s) command, a normal Write-Multiple operation will occur.

**6.1.36 Write-Sector(s) – 30H or 31H**

Bit ->	7	6	5	4	3	2	1	0
<b>Command (7)</b>	30H or 31H							
<b>C/D/H (6)</b>	X	LBA	X	Drive	Head (LBA 27-24)			
<b>Cyl High (5)</b>	Cylinder High (LBA 23-16)							
<b>Cyl Low (4)</b>	Cylinder Low (LBA 15-8)							
<b>Sec Num (3)</b>	Sector Number (LBA 7-0)							
<b>Sec Cnt (2)</b>	Sector Count							
<b>Feature (1)</b>	X							

This command writes from 1 to 256 sectors as specified in the Sector Count register. A sector count of zero requests 256 sectors. The transfer begins at the sector specified in the Sector Number register.

When this command is accepted, the ATA-Disk Chip sets BSY, then sets DRQ and clears BSY, then waits for the host to fill the sector buffer with the data to be written. No interrupt is generated to start the first host transfer operation. No data should be transferred by the host until BSY has been cleared by the host. For multiple sectors, after the first sector of data is in the buffer, BSY will be set and DRQ will be cleared. After the next buffer is ready for data, BSY is cleared, DRQ is set and an interrupt is generated. When the final sector of data is transferred, BSY is set and DRQ is cleared. It will remain in this state until the command is completed at which time BSY is cleared and an interrupt is generated. If an error occurs during a write of more than one sector, writing terminates at the sector where the error occurs. The Command Block registers contain the cylinder, head and sector number of the sector where the error occurred. The host may then read the command block to determine what error has occurred, and on which sector.

**6.1.37 Write-Sector(s)-Without-Erase - 38H**

Bit ->	7	6	5	4	3	2	1	0
<b>Command (7)</b>	38H							
<b>C/D/H (6)</b>	X	LBA	X	Drive	Head (LBA 27-24)			
<b>Cyl High (5)</b>	Cylinder High (LBA 23-16)							
<b>Cyl Low (4)</b>	Cylinder Low (LBA 15-8)							
<b>Sec Num (3)</b>	Sector Number (LBA 7-0)							
<b>Sec Cnt (2)</b>	Sector Count							
<b>Feature (1)</b>	X							

This command is similar to the Write-Sector(s) command with the exception that an implied Erase before Write operation is not performed. This command has the same protocol as the Write-Sector(s) command. The sectors should be pre-erased with the Erase-Sector(s) command before this command is issued. If the sector is not pre-erased with the Erase-Sector(s) command, a normal Write-Sector operation will occur.

**6.1.38 Write-Verify - 3CH**

Bit ->	7	6	5	4	3	2	1	0
<b>Command (7)</b>	3CH							
<b>C/D/H (6)</b>	X	LBA	X	Drive	Head (LBA 27-24)			
<b>Cyl High (5)</b>	Cylinder High (LBA 23-16)							
<b>Cyl Low (4)</b>	Cylinder Low (LBA 15-8)							
<b>Sec Num (3)</b>	Sector Number (LBA 7-0)							
<b>Sec Cnt (2)</b>	Sector Count							
<b>Feature (1)</b>	X							

This command is similar to the Write-Sector(s) command, except each sector is verified immediately after being written. This command has the same protocol as the Write-Sector(s) command.

## 6.2 Error Posting

The following table summarizes the valid status and error values for the ATA Disk Chip command set.

**TABLE 10-6: Error and Status Register**

Command	Error Register					Status Register				
	BBK	UNC	IDNF	ABRT	AMNF	RDY	DWF	DSC	CORR	ERR
Check-Power-Mode				V		V	V	V		V
Execute-Drive-Diagnostic1						V		V		V
Format-Track			V	V	V	V	V	V		V
Identify-Drive				V		V	V	V		V
Idle				V		V	V	V		V
Idle-Immediate				V		V	V	V		V
Initialize-Drive-Parameters						V		V		V
Read-Buffer				V		V	V	V		V
Read DMA	V	V	V	V	V	V	V	V	V	V
Read-Multiple	V	V	V	V	V	V	V	V	V	V
Read-Long-Sector	V		V	V	V	V	V	V		V
Read-Sector(s)	V	V	V	V	V	V	V	V	V	V
Read-Verify-Sector(s)	V	V	V	V	V	V	V	V	V	V
Recalibrate				V		V	V	V		V
Request Sense				V		V		V		V
Security-Disable-Password				V		V	V	V		V
Security-Erase-Prepare				V		V	V	V		V
Security-Erase-Unit				V		V	V	V		V
Security-Freeze-Lock				V		V	V	V		V
Security-Set-Password				V		V	V	V		V
Security-Unlock				V		V	V	V		V
Seek			V	V		V	V	V		V
Set-Features				V		V	V	V		V
Set-Multiple-Mode				V		V	V	V		V
Set-Sleep-Mode				V		V	V	V		V
SMART			V	V		V	V	V		V
Standby				V		V	V	V		V
Standby-Immediate				V		V	V	V		V
Write-Buffer				V		V	V	V		V
Write-Long-Sector	V		V	V	V	V	V	V		V
Write DMA	V		V	V	V	V	V	V		V
Write-Multiple	V		V	V	V	V	V	V		V
Write-Sector(s)	V		V	V	V	V	V	V		V
Write-Verify	V		V	V	V	V	V	V		V
Invalid-Command-Code				V		V	V	V		V

1. See Table 11-3  
V = valid on this command

## 7. Electrical Specification

**Caution: Absolute Maximum Stress Ratings** – Applied conditions greater than those listed under “Absolute Maximum Stress Ratings” may cause permanent damage to the device. This is a stress rating only and functional operation of the device at these conditions or conditions greater than those defined in the operational sections of this data sheet is not implied. Exposure to absolute maximum stress rating conditions may affect device reliability.

**Table 7-1:** Operating range

Range	Ambient Temperature	3.3V	5V
Commercial	0°C to +70°C	2.94-3.63V	4.5-5.5V
Industrial	-40°C to +85°C		

**Table 7-2:** Absolute maximum power pin stress ratings

Parameter	Symbol	Conditions
Input Power	$V_{DD}$	-0.3V min to 6.5V max
Voltage on any flash media interface pin with respect to GND	V	-0.5V min to $V_{DD} + 0.5V$ max

**Table 7-3:** Recommended system power-up timing

Symbol	Parameter	Maximum	Units
TPU-READY <sup>1</sup>	Host Power-up/Reset to Ready Operation	500	ms
TPU-WRITE <sup>1</sup>	Host Power-up/Reset to Write Operation	500	ms

1. This parameter is measured only for initial qualification and after a design or process change that could affect this parameter.

## 7.1 DC Characteristics

**Table 7-4: DC Characteristics**

Symbol	Type	Parameter	Min	Max	Units	Conditions
$V_{IH1}$ $V_{IL1}$	I1	Input Voltage	2.0V	0.8V	V	$V_{DDQ}=V_{DDQ} \text{ Max}$ $V_{DDQ}=V_{DDQ} \text{ Min}$
$I_{IL1}$	I1Z	Input Leakage Current	-10	10	$\mu\text{A}$	$V_{IN}=\text{GND to } V_{DDQ}$ $V_{DDQ}=V_{DDQ} \text{ Max}$
$I_{U1}$	I1U	Input Pull-Up Current	-110	-1	$\mu\text{A}$	$V_{OUT}=\text{GND,}$ $V_{DDQ}=V_{DDQ} \text{ Max}$
$V_{T+2}$ $V_{T-2}$	I2	Input Voltage Schmitt Trigger	0.8	2.0	V	$V_{DDQ}=V_{DDQ} \text{ Max}$ $V_{DDQ}=V_{DDQ} \text{ Min}$
$I_{IL2}$	I2Z	Input Leakage Current	-10	10	$\mu\text{A}$	$V_{IN}=\text{GND to } V_{DDQ}$ $V_{DDQ}=V_{DDQ} \text{ Max}$
$I_{U2}$	I2U	Input Pull-Up Current	-110	-1	$\mu\text{A}$	$V_{OUT}=\text{GND,}$ $V_{DDQ}=V_{DDQ} \text{ Max}$
$V_{OH1}$ $V_{OL1}$	O1	Output Voltage	2.4	0.4	V	$I_{OH1}=I_{OH1} \text{ Min}$ $I_{OL1}=I_{OL1} \text{ Max}$
$I_{OH1}$		Output Current	-4		mA	$V_{DDQ}=V_{DDQ} \text{ Min}$
$I_{OL1}$		Output Current		4	mA	$V_{DDQ}=V_{DDQ} \text{ Min}$
$V_{OH2}$ $V_{OL2}$	O2	Output Voltage	2.4	0.4	V	$I_{OH2}=I_{OH2} \text{ Min}$ $I_{OL2}=I_{OL2} \text{ Max}$
$I_{OH2}$		Output Current	-6		mA	$V_{DDQ}=3.135\text{V}-3.465\text{V}$
$I_{OL2}$		Output Current		6	mA	$V_{DDQ}=3.135\text{V}-3.465\text{V}$
$I_{OH2}$		Output Current	-8		mA	$V_{DDQ}=4.5\text{V}-5.5\text{V}$
$I_{OL2}$		Output Current		8	mA	$V_{DDQ}=4.5\text{V}-5.5\text{V}$
$V_{OH6}$ $V_{OL6}$	O6	Output Voltage for DASP# pin	2.4	0.4	V	$I_{OH6}=I_{OH6} \text{ Min}$ $I_{OL6}=I_{OL6} \text{ Max}$
$I_{OH6}$		Output Current for DASP# pin	-3		mA	$V_{DDQ}=3.135\text{V}-3.465\text{V}$
$I_{OL6}$		Output Current for DASP# pin		8	mA	$V_{DDQ}=3.135\text{V}-3.465\text{V}$
$I_{OH6}$		Output Current for DASP# pin	-3		mA	$V_{DDQ}=4.5\text{V}-5.5\text{V}$
$I_{OL6}$		Output Current for DASP# pin		12	mA	$V_{DDQ}=4.5\text{V}-5.5\text{V}$
$I_{DD}^{1,2}$	PWR	Power supply current ( $T_a = 0^\circ\text{C to } +70^\circ\text{C}$ )		50	mA	$V_{DD}=V_{DD} \text{ Max}$ $V_{DDQ}=V_{DDQ} \text{ Max}$
$I_{DD}^{1,2}$	PWR	Power supply current ( $T_a = -40^\circ\text{C to } +85^\circ\text{C}$ )		75	mA	$V_{DD}=V_{DD} \text{ Max}$ $V_{DDQ}=V_{DDQ} \text{ Max}$
$I_{SP}$	PWR	Sleep/Standby/Idle current ( $T_a = 0^\circ\text{C to } +70^\circ\text{C}$ )		75	$\mu\text{A}$	$V_{DD}=V_{DD} \text{ Max}$ $V_{DDQ}=V_{DDQ} \text{ Max}$
$I_{SP}$	PWR	Sleep/Standby/Idle current ( $T_a = -40^\circ\text{C to } +85^\circ\text{C}$ )		200	$\mu\text{A}$	$V_{DD}=V_{DD} \text{ Max}$ $V_{DDQ}=V_{DDQ} \text{ Max}$

1. Sequential data transfer for 1 sector read data from host interface and write data to media.
2. This parameter is measured only for initial qualification and after a design or process change that could affect this parameter.

## 7.2 AC Characteristics

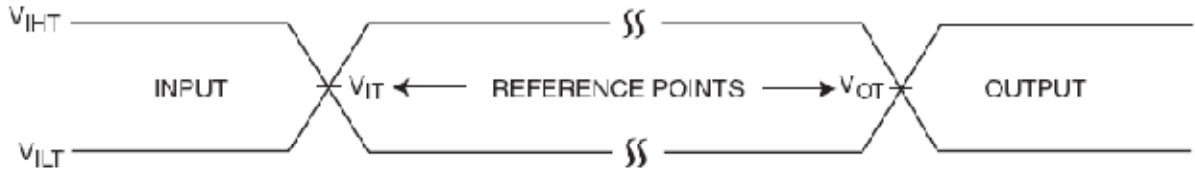

1355 F02.0

AC test inputs are driven at  $V_{IHT}$  (0.9  $V_{DD}$ ) for a logic "1" and  $V_{ILT}$  (0.1  $V_{DD}$ ) for a logic "0". Measurement reference points for inputs and outputs are  $V_{IT}$  (0.5  $V_{DD}$ ) and  $V_{OT}$  (0.5  $V_{DD}$ ). Input rise and fall times (10% ↔ 90%) are <10 ns.

**Note:**  $V_{IT}$  -  $V_{INPUT}$  Test  
 $V_{OT}$  -  $V_{OUTPUT}$  Test  
 $V_{IHT}$  -  $V_{INPUT}$  HIGH Test  
 $V_{ILT}$  -  $V_{INPUT}$  LOW Test

**7.2.1 I/O Input (Read) Timing Specification**

**Table 7-5 I/O Read Timing**

Item	Symbol	IEEE Symbol	Min <sup>1</sup>	Min <sup>1</sup>	Units
Data Delay after IORD	$T_{D(IORD)}$	tIGLQV		100	ns
Data Hold following IORD	$T_{H(IORD)}$	tIGHQX	0		ns
IORD Width Time	$T_{W(IORD)}$	tIGLIGH	165		ns
Address Setup before IORD	$T_{SUA(IORD)}$	tAVIGL	70		ns
Address Hold following IORD	$T_{HA(IORD)}$	tIGHAX	20		ns
CE Setup before IORD	$T_{SUCE(IORD)}$	tELIGL	5		ns
CE Hold following IORD	$T_{HCE(IORD)}$	tIGHEH	20		ns
REG Setup before IORD	$T_{SUREG(IORD)}$	tRGLIGL	5		ns
REG Hold following IORD	$T_{HREG(IORD)}$	tIGHRGH	0		ns
INPACK Delay Falling from IORD	$T_{DFINPACK(IORD)}$	tIGLIAL	0	45	ns
INPACK Delay Rising from IORD	$T_{DRINPACK(IORD)}$	tIGHIAH		45	ns
IOIS16 Delay Falling from Address	$T_{DFIOIS16(ADR)}$	tAVISL		35	ns
IOIS16 Delay Rising from Address	$T_{DRIOIS16(ADR)}$	tAVISH		35	ns

1. All AC specifications are guaranteed by design.

Note: The maximum load on -INPACK and IOIS16# is 1 LSTTL with 50pF total load.

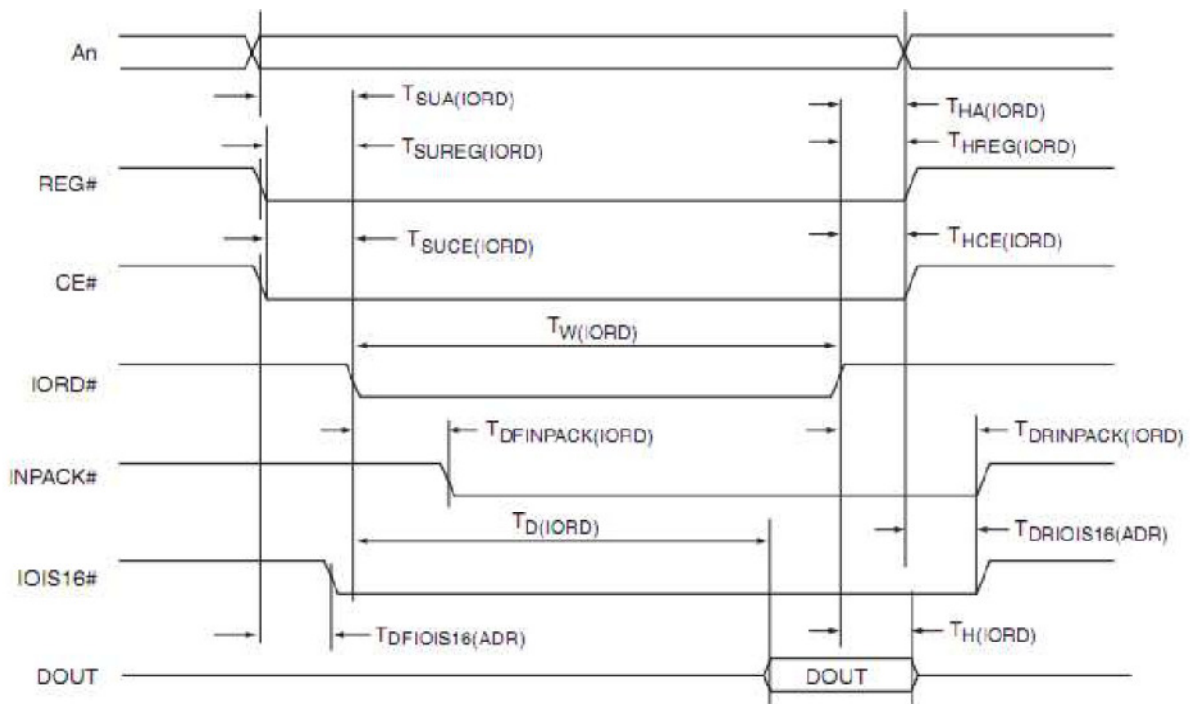

**Figure 7-1: I/O Read Timing Diagram**

**7.2.2 I/O Output (Write) Timing Specification**

**Table 7-6 I/O Write Timing**

Item	Symbol	IEEE Symbol	Min <sup>1</sup>	Min <sup>1</sup>	Units
Data Setup before IOWR	$T_{SU(IOWR)}$	tDVIWH	60		ns
Data Hold following IOWR	$T_{H(IOWR)}$	tIWHDX	30		ns
IOWR Width Time	$T_{W(IOWR)}$	tIWLWH	165		ns
Address Setup before IOWR	$T_{SUA(IOWR)}$	tAVIWL	70		ns
Address Hold following IOWR	$T_{HIA(IOWR)}$	tIWHAX	20		ns
CE Setup before IOWR	$T_{SUCE(IOWR)}$	tELIWL	5		ns
CE Hold following IOWR	$T_{HCE(IOWR)}$	tIWHHEH	20		ns
REG Setup before IOWR	$T_{SUREG(IOWR)}$	tRGLIWL	5		ns
REG Hold following IOWR	$T_{HREG(IOWR)}$	tIWHRGH	0		ns
IOIS16 Delay Falling from Address	$T_{DFIOIS16(ADR)}$	tAVISL		35	ns
IOIS16 Delay Rising from Address	$T_{DRICIS16(ADR)}$	tAVISH		35	ns

1. All AC specifications are guaranteed by design.  
 Note: The maximum load on -INPACK and IOIS16# is 1 LSTTL with 50pF total load.

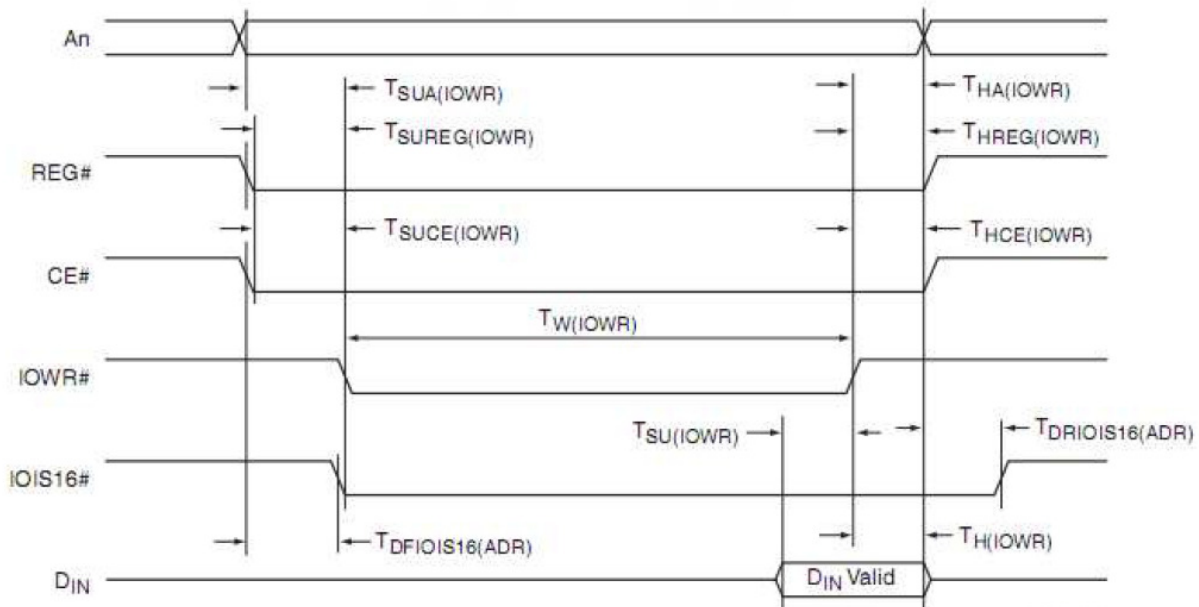

**Figure 7-2: I/O Write Timing Diagram**





## 9.2 Valid Combinations

### 9.2.1 Standard Temperature

3.3V – UDMA		5V - UDMA	
Capacity	Model Number	Capacity	Model Number
128M	FMS-FC0128M0S3DS-S	128M	FMS-FC0128M0S5DS-S
256M	FMS-FC0256M0S3DS-S	256M	FMS-FC0256M0S5DS-S
512M	FMS-FC0512M0S3DS-S	512M	FMS-FC0512M0S5DS-S
1GB	FMS-FC001GM0S3DS-S	1GB	FMS-FC001GM0S5DS-S
2GB	FMS-FC002GM0S3DS-S	2GB	FMS-FC002GM0S5DS-S
4GB	FMS-FC004GM0D3DS-S	4GB	FMS-FC004GM0D5DS-S
8GB	FMS-FC008GM0D3DS-T	8GB	FMS-FC008GM0D5DS -T

3.3V – PIO		5V - PIO	
Capacity	Model Number	Capacity	Model Number
128M	FMS-FC0128M0S3PS-S	128M	FMS-FC0128M0S5PS-S
256M	FMS-FC0256M0S3PS-S	256M	FMS-FC0256M0S5PS-S
512M	FMS-FC0512M0S3PS-S	512M	FMS-FC0512M0S5PS-S
1GB	FMS-FC001GM0S3PS-S	1GB	FMS-FC001GM0S5PS-S
2GB	FMS-FC002GM0S3PS-S	2GB	FMS-FC002GM0S5PS-S
4GB	FMS-FC004GM0D3PS-S	4GB	FMS-FC004GM0D5PS-S
8GB	FMS-FC008GM0D3PS-T	8GB	FMS-FC008GM0D5PS -T

3.3V – MWDMA		5V - MWDMA	
Capacity	Model Number	Capacity	Model Number
128M	FMS-FC0128M0S3MS-S	128M	FMS-FC0128M0S5MS-S
256M	FMS-FC0256M0S3MS-S	256M	FMS-FC0256M0S5MS-S
512M	FMS-FC0512M0S3MS-S	512M	FMS-FC0512M0S5MS-S
1GB	FMS-FC001GM0S3MS-S	1GB	FMS-FC001GM0S5MS-S
2GB	FMS-FC002GM0S3MS-S	2GB	FMS-FC002GM0S5MS-S
4GB	FMS-FC004GM0D3MS-S	4GB	FMS-FC004GM0D5MS-S
8GB	FMS-FC008GM0D3MS-T	8GB	FMS-FC008GM0D5MS -T

**9.2.2 Industrial Temperature**

<b>3.3V – UDMA</b>		<b>5V - UDMA</b>	
<b>Capacity</b>	<b>Model Number</b>	<b>Capacity</b>	<b>Model Number</b>
<b>128M</b>	FMS-FC0128M0S3DS-IS	<b>128M</b>	FMS-FC0128M0S5DS-IS
<b>256M</b>	FMS-FC0256M0S3DS-IS	<b>256M</b>	FMS-FC0256M0S5DS-IS
<b>512M</b>	FMS-FC0512M0S3DS-IS	<b>512M</b>	FMS-FC0512M0S5DS-IS
<b>1GB</b>	FMS-FC001GM0S3DS-IS	<b>1GB</b>	FMS-FC001GM0S5DS-IS
<b>2GB</b>	FMS-FC002GM0S3DS-IS	<b>2GB</b>	FMS-FC002GM0S5DS-IS
<b>4GB</b>	FMS-FC004GM0D3DS-IS	<b>4GB</b>	FMS-FC004GM0D5DS-IS
<b>8GB</b>	FMS-FC008GM0D3DS-IT	<b>8GB</b>	FMS-FC008GM0D5DS -IT

<b>3.3V – PIO</b>		<b>5V - PIO</b>	
<b>Capacity</b>	<b>Model Number</b>	<b>Capacity</b>	<b>Model Number</b>
<b>128M</b>	FMS-FC0128M0S3PS-IS	<b>128M</b>	FMS-FC0128M0S5PS-IS
<b>256M</b>	FMS-FC0256M0S3PS-IS	<b>256M</b>	FMS-FC0256M0S5PS-IS
<b>512M</b>	FMS-FC0512M0S3PS-IS	<b>512M</b>	FMS-FC0512M0S5PS-IS
<b>1GB</b>	FMS-FC001GM0S3PS-IS	<b>1GB</b>	FMS-FC001GM0S5PS-IS
<b>2GB</b>	FMS-FC002GM0S3PS-IS	<b>2GB</b>	FMS-FC002GM0S5PS-IS
<b>4GB</b>	FMS-FC004GM0D3PS-IS	<b>4GB</b>	FMS-FC004GM0D5PS-IS
<b>8GB</b>	FMS-FC008GM0D3PS-IT	<b>8GB</b>	FMS-FC008GM0D5PS -IT

<b>3.3V – MWDMA</b>		<b>5V - MWDMA</b>	
<b>Capacity</b>	<b>Model Number</b>	<b>Capacity</b>	<b>Model Number</b>
<b>128M</b>	FMS-FC0128M0S3MS-IS	<b>128M</b>	FMS-FC0128M0S5MS-IS
<b>256M</b>	FMS-FC0256M0S3MS-IS	<b>256M</b>	FMS-FC0256M0S5MS-IS
<b>512M</b>	FMS-FC0512M0S3MS-IS	<b>512M</b>	FMS-FC0512M0S5MS-IS
<b>1GB</b>	FMS-FC001GM0S3MS-IS	<b>1GB</b>	FMS-FC001GM0S5MS-IS
<b>2GB</b>	FMS-FC002GM0S3MS-IS	<b>2GB</b>	FMS-FC002GM0S5MS-IS
<b>4GB</b>	FMS-FC004GM0D3MS-IS	<b>4GB</b>	FMS-FC004GM0D5MS-IS
<b>8GB</b>	FMS-FC008GM0D3MS-IT	<b>8GB</b>	FMS-FC008GM0D5MS -IT

## 10. Revision History

Revision	Date	Description	Comments
1.0	2/25/2011	Initial Release	
1.1	3/10/2011	Updated Capacity Specification & Performance & Power Consumption value & Command Set	
1.2	3/21/2011	General Description Revised	