

RoHS Compliant

SATA Disk Module 3 Series
Datasheet for SDM3 7 Pin / 180 Degree
Medium Profile Module

July 18, 2011

Revision 1.1

This Specification Describes the Features and Capabilities of
Industrial and Standard Temperature
SATA Disk Modules

Please Contact Fortasa Memory Systems Sales for any
Custom Features Required For Your Specific Application



4151 Middlefield Road
2nd Floor
Palo Alto, CA 94303 USA
888-367-8588
www.fortasa.com

Features:

- **Standard Serial SATA 2.5 (Gen. 2)**
 - SATA command set compatible
 - Serial SATA II – 3.0Gbps
- **Connector Type**
 - 7-pin signal connector
 - 2-pin power connector
- **Low power consumption (typical)**
 - Supply voltage: 5V
 - Active mode: 180 mA
 - Sleep mode: 55 mA
- **Performance**
 - Burst transfer rate: 300 MB/sec
 - Sustained read: up to 55 MB/sec
 - Sustained write: up to 50 MB/sec
- **Capacity**
 - 512MB, 1, 2, 4, 8GB
- **NAND flash type: SLC**
- **Superior Reliability Through Built-in Hardware ECC**
 - Built-in hardware BCH ECC, correcting 14-bit or 28-bit error per 1024-byte data sector
- **Temperature ranges**
 - Operation:
 - Standard Temperature: 0°C to 70°C
 - Industrial Temperature: -40°C to 85°C
 - Storage: -40°C to 100°C
- **Flash management**
 - Intelligent endurance design
 - Advanced wear-leveling algorithms*
 - S.M.A.R.T. Technology*
 - ATA Secure Erase*
 - Trim*
 - Intelligent power failure recovery
- **RoHS compliant**

Table of Contents

1. General Description.....	5
2. Functional Block.....	5
3. Pin Assignments.....	6
4. Product Specification	7
4.1 Functional Specification	7
4.1.1 Capacity Specifications	7
4.1.2 SATA Mode Support.....	7
4.2 Performance Specification	7
5. Flash Management	8
5.1 Intelligent Flash Controller Features	8
5.1.1 Advanced wear-leveling algorithms	8
5.1.2 S.M.A.R.T. technology.....	8
5.1.3 Built-in hardware ECC	8
5.1.4 Enhanced data integrity	8
5.2 Intelligent Power Failure Recovery	8
6. Software Interface	9
6.1 Command Set.....	9
6.1.1 Check-Power-Mode – E5H or 98H	10
6.1.2 Execute-Drive-Diagnostic – 90H	10
6.1.3 Flush-Cache – E7H	11
6.1.4 Identify-Drive – ECH	11
6.1.5 Idle – E3H or 97H	20
6.1.6 Idle-Immediate – E1H or 95H.....	20
6.1.7 Initialize-Drive-Parameters – 91H.....	20
6.1.8 Read DMA – C8H or C9H.....	21
6.1.9 Read-Multiple – C4H	21
6.1.10 Read Sectors – 20H or 21H.....	22
6.1.11 Read Verify Sector(s) – 40H or 41H	23
6.1.12 Recalibrate – 1XH.....	23
6.1.13 Security-Disable-Password – F6H.....	24
6.1.14 Security-Erase-Prepare – F3H.....	24



6.1.15 Security-Erase-Unit – F4H.....	25
6.1.16 Security-Freeze-Lock – F5H.....	25
6.1.17 Security-Set-Password – F1H.....	26
6.1.18 Security-Unlock – F2H.....	27
6.1.19 Seek – 7XH.....	27
6.1.20 Set-Features – EFH.....	28
6.1.21 SMART – B0H.....	29
6.1.22 Standby – E2H or 96H.....	32
6.1.23 Standby-Immediate – E0H or 94H.....	33
6.1.24 Write-DMA – CAH or CBH.....	33
6.1.25 Write-Multiple – C5H.....	34
6.1.26 Write-Sector(s) – 30H or 31H.....	35
7. Electrical Specification.....	37
8. Environmental Specifications.....	38
8.1 Environments.....	38
8.2 Mean Time Between Failures (MTBF).....	38
8.3 Certification and Compliance.....	38
9. Physical Characteristics.....	39
9.1 Dimensions.....	39
9.1.1 Power Cable Type.....	39
9.1.2 Power Cable-less Type.....	40
10. Product Ordering Information.....	41
10.1 Product Code Designations.....	41
10.2 Valid Combinations.....	42
11. Revision History.....	43

1. General Description

Fortasa's SATA-Disk Module (SDM) is a high-performance, SATA interface, solid state drive (SSD) designed to replace a conventional SATA hard disk drive. SDM supports standard SATA protocol and can be plugged into a standard SATA connector commonly found in rugged laptops, military devices, thin clients, Point of Sale (POS) terminals, telecom, medical instruments, surveillance systems and industrial PCs. Fortasa SDM Series is the best drop-in replacement for high-maintenance HDD where reliability is of a major importance.

SATA Disk Module includes a built-in microcontroller and file management firmware that communicates through the SATA standard interface. This means the SDM does not require any additional or proprietary host software such as the Flash File System (FFS) and Memory Technology Driver (MTD) software. SDM is designed to work at 5 Volts and uses a standard SATA driver that fits to all major operating systems such as Microsoft's Windows series, MAC OS, and UNIX variants.

SDM offers capacities of up to 8 gigabytes, providing full support for the SATA II high-speed interface standard. It can operate at sustained access rates of up to 30 megabytes per second, which is much faster than other solid-state or traditional HDD SATA drives currently available on the market.

SDM offers high reliability global data wear-leveling scheme to allow uniform use of all storage blocks, increasing the lifetime of Flash media and optimizing drive performance. It also offers Self-Monitoring Analysis and Reporting Technology (S.M.A.R.T.) feature that follows the SATA Rev. 2.5, ATA/ATAPI-7 specifications and uses the standard SMART command B0h to read data from the drive. This capability monitors the drive accesses and provides the host with vital information about drive condition to schedule maintenance and service times.

2. Functional Block

The SATA Disk Module includes a controller and flash media, as well as the SATA standard interface. Figure 2-1 shows the functional block diagram.

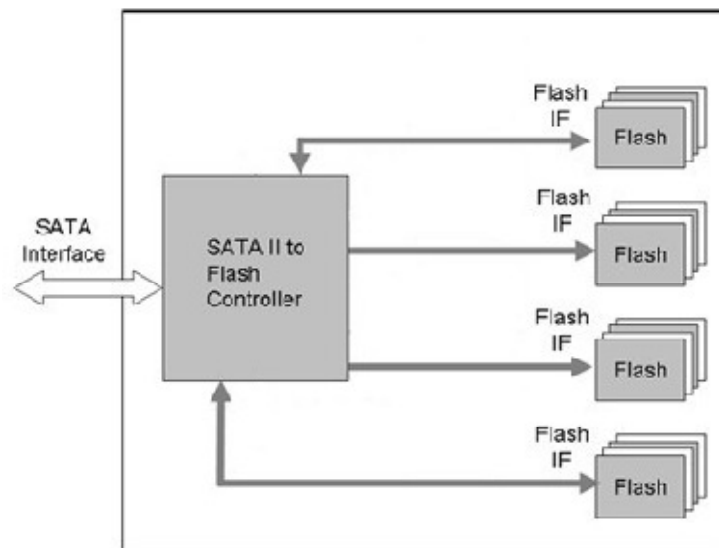

Figure 2-1: Functional block diagram

3. Pin Assignments

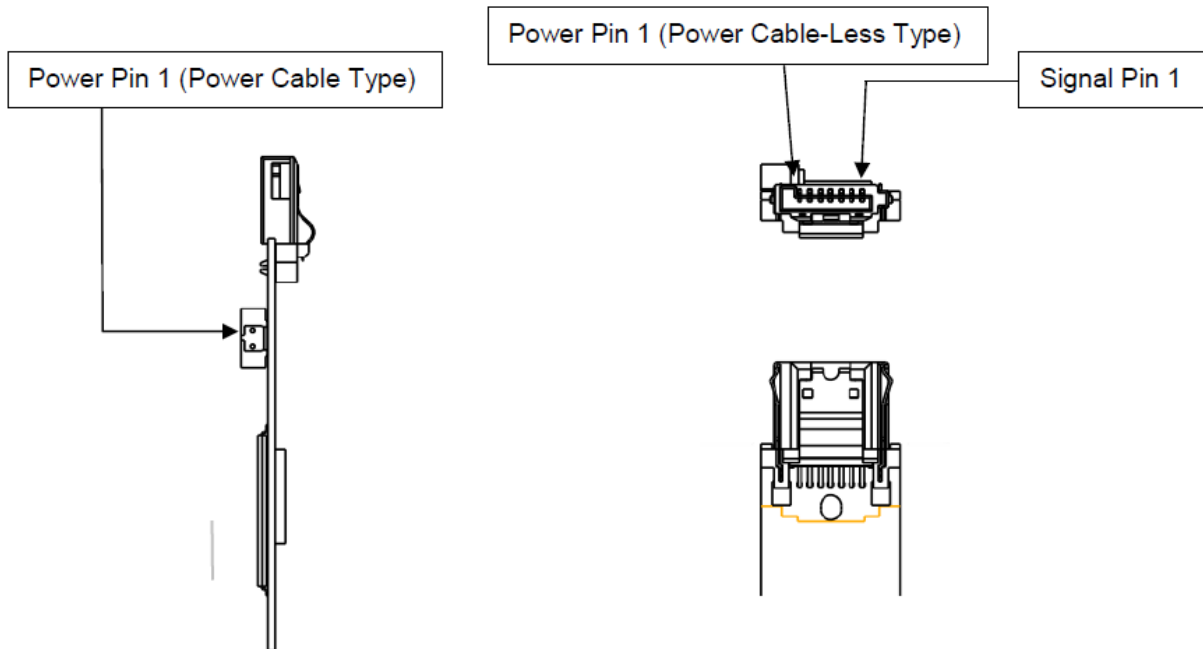

Table 3-1: Signal Segment

Pin	Signal	Description
S1		Ground
S2	RxP	Serial Data Receiver
S3	RxN	
S4		Ground
S5	TxN	Serial Data Transmitter
S6	TxP	
S7		Ground

Table 3-2: Power Segment

Pin	Signal
P1	Vcc (5V)
P2	GND

4. Product Specification

4.1 Functional Specification

4.1.1 Capacity Specifications

Standard capacity specification of the SATA Disk Module product is shown in Table 4-1. The table lists the specific capacity and the default numbers of heads, sectors and cylinders (CHS) for each product line.

Table 4-1: Capacity specifications

Capacity	Total Bytes	Cylinders	Heads	Sectors	Max LBA
512MB	494,936,064	959	16	63	966,672
1GB	988,839,936	1,916	16	63	1,931,328
2GB	1,982,324,736	3,841	16	63	3,871,728
4GB	3,952,263,168	7,658	16	63	7,719,264
8GB	7,913,816,064	15,334	16	63	15,456,672

1. Cylinders, heads or sectors are not applicable for these capacities. Only LBA addressing applies.

Please contact factory for any non-listed SATA Disk Module capacity or custom CHS requirement.

4.1.2 SATA Mode Support

The SATA-Disk Module supports the following SATA operating modes:

- Supports up to PIO Mode-4
- Supports up to Multi-word DMA Mode-2
- Supports up to Ultra DMA Mode-5

4.2 Performance Specification

Performances of the SATA Disk Module are listed in Table 4-2.

Table 4-2: Standard Performance specifications

Capacity	512MB	1GB	2GB	4GB	8GB
Performance					
Sustained read (MB/s)	50	50	55	55	55
Sustained write (MB/s)	18	16	24	50	50

5. Flash Management

The most critical attribute of an Industrial grade SATA Disk Module is its inherent high level of reliability. This characteristic is achieved through unique technical features of Flash Controller and specific component selection that offer higher degree of reliability compared to the consumer grade components.

5.1 Intelligent Flash Controller Features

5.1.1 Advanced wear-leveling algorithms

All NAND flash devices are limited by a finite number of write cycles. Under a standard file system, frequent file table updates are mandatory. As a painful side effect of OS file overhead, some areas of flash address space wear out faster than others. As these certain sections get a substantially higher write occurrence the whole SATA Disk Module can wear out very quickly. This uneven wear would significantly reduce the lifetime of the whole device, even if majority of the Flash sectors are far from the write cycle limit. Fortasa's SATA Disk Module products offer advanced data wear leveling which distributes Flash writes evenly across the SATA Disk Module memory space. By utilizing this advanced wear leveling feature, the lifetime of the media can be significantly extended.

5.1.2 S.M.A.R.T. technology

S.M.A.R.T. is an acronym for Self-Monitoring, Analysis and Reporting Technology, an open standard allowing disk drives to automatically monitor their own health and report potential problems. It protects the user from unscheduled downtime by monitoring and storing critical drive performance and calibration parameters. Ideally, this feature allows the host to take proactive actions to prevent impending drive failure.

Fortasa SDM3 uses the standard SMART command B0h to read data from the drive per SATA Rev.2.6 ATA/ATAPI-7 specifications. Based on the SFF-8035i Rev. 2.0 specifications, Fortasa SMART command defines vendor-specified SMART Attribute IDs (A0h, A1h, A2h, A3h, A4h-A5h) in SDM3. These attributes represent initial back block count, bad block count, spare block count, maximum erase count, and average erase counts respectively. By having the Fortasa SMART Utility running on the host, the system can monitor and analyze the SATA Disk Module status and determine the end of useful life for a graceful and scheduled maintenance and replacement.

5.1.3 Built-in hardware ECC

The Fortasa Flash Controller uses superior BCH Error Detection Code (EDC) and Error Correction Code (ECC) algorithms which can detect and correct up to 14 bits or 28 bits error in 1K bytes.. High performance is achieved through hardware-based error detection and correction.

5.1.4 Enhanced data integrity

The properties of NAND flash memory make it ideal for applications that require high integrity while operating in challenging environments. The integrity of data to NAND flash memory is generally maintained through ECC algorithms and bad block management. Flash controllers can support up to 8 bits ECC capability for accuracy of data transactions, and bad block management is a preventive mechanism from loss of data by retiring unusable media blocks and relocating the data to the other blocks, along with the integration of advanced wear leveling algorithms, so that the lifespan of device can be expanded.

5.2 Intelligent Power Failure Recovery

The Low Power Detection on the Flash controller initiates cached data saving before the power supply to the device drops too low for operation. This feature prevents the device from system crash and ensures data integrity during an unexpected brownout. This feature makes sure that there are no catastrophic failures of the SATA Disk Module due to system power glitches.

6. Software Interface

6.1 Command Set

Table 6-1 summarizes the command set with the paragraphs that follow describing the individual commands and the task file for each.

Table 6-1: Command set

Command	Code	FR ¹	SC ²	SN ³	CY ⁴	DH ⁵	LBA ⁶
Check-Power-Mode	E5H	-	-	-	-	D8	-
Execute-Drive-Diagnostic	90H	-	-	-	-	D	-
Flush-Cache	E7H	-	-	-	-	D	-
Identify-Drive	ECH	-	-	-	-	D	-
Idle	E3H	-	Y	-	-	D	-
Idle-Immediate	E1H	-	-	-	-	D	-
Initialize-Drive-Parameters	91H	-	Y	-	-	Y	-
Read DMA	C8H or C9H	-	Y	Y	Y	Y	Y
Read-Multiple	C4H	-	Y	Y	Y	Y	Y
Read-Sector(s)	20H or 21H	-	Y	Y	Y	Y	Y
Read-Verify-Sector(s)	40H or 41H	-	Y	Y	Y	Y	Y
Recalibrate	1XH	-	-	-	-	D	-
Security-Disable-Password	F6H	-	-	-	-	D	-
Security-Erase-Prepare	F3H	-	-	-	-	D	-
Security-Erase-Unit	F4H	-	-	-	-	D	-
Security-Freeze-Lock	F5H	-	-	-	-	D	-
Security-Set-Password	F1H	-	-	-	-	D	-
Security-Unlock	F2H	-	-	-	-	D	-
Seek	7XH	-	-	Y	Y	Y	Y
Set-Features	EFH	Y	-	-	-	D	-
SMART	B0H	Y	Y	Y	Y	D	-
Set-Multiple-Mode	C6H	-	Y	-	-	D	-
Set-Sleep-Mode	E6H	-	-	-	-	D	-
Stand-By	E2H	-	-	-	-	D	-
Stand-By-Immediate	E0H	-	-	-	-	D	-
Write DMA	CAH	-	Y	Y	Y	Y	Y
Write-Multiple	C5H	-	Y	Y	Y	Y	Y
Write-Sector(s)	30H	-	Y	Y	Y	Y	Y

1. FR - Features register

2. SC - Sector Count register

3. SN - Sector Number register

4. CY - Cylinder registers

5. DH - Drive/Head register

6. LBA - Logical Block Address mode supported (see command descriptions for use)

7. Y - The register contains a valid parameter for this command

8. For the Drive/Head register:

Y means both the SDM and Head parameters are used

D means only the SDM parameter is valid and not the Head parameter

6.1.1 Check-Power-Mode - E5H or 98H

Bit ->	7	6	5	4	3	2	1	0
Command (7)	98H or E5H							
C/D/H (6)	X			Drive	X			
Cyl High (5)					X			
Cyl Low (4)					X			
Sec Num (3)					X			
Sec Cnt (2)					X			
Feature (1)					X			

This command checks the power mode. Because the SATA Disk Module can recover from sleep in 200ns, idle mode is never enabled. The SATA Disk Module sets BSY, sets the Sector Count register to 00H, clears BSY and generates an interrupt.

6.1.2 Execute-Drive-Diagnostic - 90H

Bit ->	7	6	5	4	3	2	1	0
Command (7)	90H							
C/D/H (6)	X			Drive	X			
Cyl High (5)					X			
Cyl Low (4)					X			
Sec Num (3)					X			
Sec Cnt (2)					X			
Feature (1)					X			

This command performs the internal diagnostic tests implemented by the SATA Disk Module. If the Drive bit is ignored and the diagnostic command is executed by both the Master and the Slave with the Master responding with status for both devices, the Diagnostic codes shown in Table 6-2 are returned in the Error register at the end of the command.

Table 6-2: Diagnostic codes

Code	Error Type
01H	No Error Detected
02H	Formatter Device Error
03H	Sector Buffer Error
04H	ECC Circuitry Error
05H	Controlling Microprocessor Error
8XH	Slave Error

6.1.3 Flush-Cache - E7H

Bit ->	7	6	5	4	3	2	1	0
Command (7)	E7H							
C/D/H (6)	X			Drive	X			
Cyl High (5)					X			
Cyl Low (4)					X			
Sec Num (3)					X			
Sec Cnt (2)					X			
Feature (1)					X			

This command causes the SATA Disk Module to complete writing data from its cache. The SATA Disk Module then clears BSY and generates an interrupt.

6.1.4 Identify-Drive - ECH

Bit ->	7	6	5	4	3	2	1	0
Command (7)	ECH							
C/D/H (6)	X			Drive	X			
Cyl High (5)					X			
Cyl Low (4)					X			
Sec Num (3)					X			
Sec Cnt (2)					X			
Feature (1)					X			

The Identify-Drive command enables the host to receive parameter information from the SATA Disk Module. This command has the same protocol as the Read-Sector(s) command. The parameter words in the buffer have the arrangement and meanings defined in Table 6-3. All reserved bits or words are zero. Table 6-3 is the definition for each field in the Identify-Drive Information.

Table 6-3: Identify-Drive information (1 of 3)

Word Address	Default Value	Total Bytes	Data Field Type Information
0	0040H	2	General configuration bit-significant information
1	bbbbH ²	2	Default number of cylinders
2	C837H	2	Reserved
3	00bbH ²	2	Default number of heads
4-5	xxxxH	4	Reserved
6	bbbbH ²	2	Default number of sectors per track
7-8	bbbbH ²	4	Number of sectors per device (Word 7 = MSW, Word 8 = LSW)
9	000EH	2	Vendor Unique
10-19	ddddH ⁴	20	Unique serial number in ASCII
20	xxxxH	2	Retired
21	xxxxH	2	Retired
22	003FH	2	Obsolete

Table 6-3: Identify-Drive information (2 of 3)

Word Address	Default Value	Total Bytes	Data Field Type Information
23-26	aaaaH ⁵	8	Firmware revision in ASCII. Big Endian Byte Order in Word
27-46	xxxxH	40	User Definable Model number/name
47	8000H	2	Maximum number of sectors on Read/Write-Multiple command
48	4000H	2	Reserved
49	2F00H	2	Capabilities
50	4000H	2	Reserved
51	0280H	2	PIO data transfer cycle timing mode
52	0000H	2	Obsolete
53	0007H	2	Translation parameters are valid
54	nnnnH ³	2	Current numbers of cylinders
55	nnnnH ³	2	Current numbers of heads
56	nnnnH ³	2	Current sectors per track
57-58	nnnnH ³	4	Current capacity in sectors (LBAs) (Word 57 = LSW, Word 58 = MSW)
59	0000H	2	Multiple sector setting
60-61	nnnnH ³	4	Total number of sectors addressable in LBA Mode
62	0000H	2	Reserved
63	0007H	2	DMA data transfer is supported in SATA Disk Module Controller
64	0003H	2	Advanced PIO Transfer Mode Supported
65	0078H	2	120ns cycle time support for Multiword DMA Mode-2
66	0078H	2	120ns cycle time support for Multiword DMA Mode-2
67	0078H	2	PIO Mode-4 supported
68	0078H	2	PIO Mode-4 supported
69-79	0000H	20	Reserved
80	01FEH	2	ATA/ATAPI major version number
81	0021H	2	ATA/ATAPI minor version number
82	0068H	2	Features/command sets supported
83	5000H	2	Features/command sets supported
84	4000H	2	Features/command sets supported
85	0008H	6	Features/command sets Enabled
86	5000H	6	Features/command sets Enabled
87	4000H	6	Features/command sets Default
88	203FH	2	Ultra DMA Mode supported and selected
89	0000H	2	Time required for security erase unit completion
90	0000H	2	Time required for enhanced security erase unit completion

Table 6-3: Identify-Drive information (3 of 3)

Word Address	Default Value	Total Bytes	Data Field Type Information
91-127	0000H	74	Reserved
128	0001H	2	Security Status
129-159	0000H	62	Vendor unique bytes
160-254	0000H	94	Reserved
255	0000H	2	Integrity Word

1. 1. XXXX=This field is subject to change by the host or the device
2. 2. bbbb - default value set by controller. The selections could be user programmable.
3. 3. n - calculated data based on product configuration
4. 4. dddd - unique number of each device
5. 5. aaaa - any unique firmware revision
6. The user has an option to change the model number during manufacturing.

1. Word 0: General Configuration

This field informs the host that this is a non-magnetic, hard sectored, non-removable storage device with a transfer rate greater than 10 MB/sec and is not MFM encoded.

2. Word 1: Default Number of Cylinders

This field contains the number of translated cylinders in the default translation mode. This value will be the same as the number of cylinders.

3. Word 3: Default Number of Heads

This field contains the number of translated heads in the default translation mode.

4. Word 6: Default Number of Sectors per Track

This field contains the number of sectors per track in the default translation mode.

5. Word 7-8: Reserved for assignment by CompactFlash Association

6. Word 10-19: Serial Number

Unique serial number ID. The twenty bytes are a user-programmable value with a default value of spaces.

7. Word 23-26: Firmware Revision

This field contains the revision of the firmware for this product.

7. Word 27-46: Model Number

This field contains the model number for this product.

8. Word 47: Read-/Write-Multiple Sector Count

This field contains the maximum number of sectors that can be read or written per interrupt using the Read-Multiple or Write-Multiple commands. Only a value of '1' is supported.

9. Word 49: Capabilities

Bit	Function
13	Standby Timer 1: Standby timer values as specified in this standard are supported. 0: Standby timer values shall be managed by the device.
11	IRDY Supported 1: IRDY supported. 0: IRDY maybe supported.
10	IRDY Enabled 1: IRDY maybe disabled.
9	LBA Support 1: LBA mode addressing is supported.
8	DMA Support 1: DMA mode is supported.

10. Word 51: PIO Data Transfer Cycle Timing Mode

This field defines the mode for PIO data transfer. The SATA Disk Module supports up to PIO Mode-4

11. Word 53: Translation Parameters Valid

Bit	Function
0	1: Words 54-58 are valid and reflect the current number of cylinders, heads and sectors.
1	1: Words 64-70 are valid to support PIO Mode-3 and 4.
2	1: Word 88 is valid to support Ultra DMA data transfer.

12. Word 54-56: Current Number of Cylinders, Heads, Sectors/Track

These fields contain the current number of user addressable Cylinders, Heads, and Sectors/Track in the current translation mode.

13. Word 57-58: Current Capacity

This field contains the product of the current cylinders times heads times sectors.

14. Word 59: Multiple Sector Setting

This field contains a validity flag in the Odd Byte and the current numbers of sectors that can be transferred per interrupt for R/W Multiple in the Even Byte. The Odd Byte is always 01H which indicates that the Even Byte is always valid.

The Even Byte value depends on the value set by the Set Multiple command. The Even Byte of this word by default contains a 00H which indicates that R/W Multiple commands are not valid.

15. Word 60-61: Total Sectors Addressable in LBA Mode

This field contains the number of sectors addressable for the SATA Disk Module in LBA mode only.

16. Word 63: Multiword DMA Transfer

This field identifies the Multiword DMA transfer modes supported by the SATA Disk Module and indicates the mode that is currently selected. Only one DMA mode shall be selected at any given time.

Bit	Function
-----	----------

15-11	Reserved
10	Multiword DMA mode-2 selected
1:	Multiword DMA mode-2 is selected and bits 8 and 9 are cleared to 0.
0:	Multiword DMA mode-2 is not selected.
9	Multiword DMA mode-1 selected
1:	Multiword DMA mode-1 is selected and 8 and 10 shall be cleared to 0.
0:	Multiword DMA mode-1 is not selected.
8	Multiword DMA mode-0 selected
1:	Multiword DMA mode-0 is selected and bits 9 and 10 are cleared to 0.
0:	Multiword DMA mode-0 is not selected.
7-3	Reserved
2	Multiword DMA mode-2 supported
1:	Multiword DMA mode-2 and below are supported and Bits 0 and 1 shall be set to 1.
1	Multiword DMA mode-1 supported
1:	Multiword DMA mode-1 and below are supported.
0	Multiword DMA mode-0 supported
1:	Multiword DMA mode-0 is supported.

17. Word 64: Advanced PIO Data Transfer Mode

Bit (7:0) is defined as the PIO data and register transfer supported field. If this field is supported, Bit 1 of word 53 shall be set to one. This field is bit significant. Any number of bits may be set to one in this field by the device to indicate the PIO modes the device is capable of supporting. Of these bits, bit (7:2) are Reserved for future PIO modes.

Bit	Function
-----	----------

0	1:	PIO Mode-3 is supported.
1	1:	PIO Mode-4 is supported.

18. Word 65: Minimum Multiword DMA Transfer Cycle Time Per Word

This field defines the minimum Multiword DMA transfer cycle time per word. This field defines, in nanoseconds, the minimum cycle time that the SATA Disk Module supports when performing Multiword DMA transfers on a per word basis. The SATA Disk Module supports up to Multiword DMA Mode-2, so this field is set to 120ns.

19. Word 66: Device Recommended Multiword DMA Cycle Time

This field defines the SATA Disk Module recommended Multiword DMA transfer cycle time. This field defines, in nanoseconds, the minimum cycle time per word during a single sector host transfer while performing a multiple sector READ DMA or WRITE DMA command for any location on the media under nominal conditions. If a host runs at a faster cycle rate by operating at a cycle time of less than this value, the SATA Disk Module may negate DMARQ for flow control. The rate at which DMARQ is negated could result in reduced throughput despite the faster cycle rate. Transfer at this rate does not ensure that flow control will not be used, but implies that higher performance may result. The SATA Disk Module supports up to Multiword DMA Mode-2, so this field is set to 120ns.

20. Word 67: Minimum PIO Transfer Cycle Time Without Flow Control

This field defines, in nanoseconds, the minimum cycle time that, if used by the host, the device guarantees data integrity during the transfer without utilization of IORDY flow control. If this field is supported, Bit 1 of word 53 shall be set to one. The SATA Disk Module minimum cycle time is 120ns. A value of 0078H is reported.

21. Word 68: Minimum PIO Transfer Cycle Time with IORDY

This field defines, in nanoseconds, the minimum cycle time that the device supports while performing data transfer while utilizing IORDY flow control. If this field is supported, Bit 1 of word 53 shall be set to one. The SATA Disk Module minimum cycle time is 120 ns, e.g., PIO mode 4. A value of 0078H is reported.

22. Word 80: Major Version Number

If not 0000H or FFFFH, the device claims compliance with the major version(s) as indicated by bits (6:1) being set to one. Since SATA standards maintain downward compatibility, a device may set more than one bit. The SATA Disk Module supports ATA-1 to ATA-7.

23. Word 81: Minor Version Number

If an implementer claims that the revision of the standard they used to guide their implementation does not need to be reported or if the implementation was based upon a standard prior to the SATA-3 standard, word 81 shall be 0000H or FFFFH. A value of 0021H reported in word 81 indicates SATA/ATAPI-7 guided the implementation.

24. Words 82-84: Features/command sets supported

Words 82, 83, and 84 indicate the features and command sets supported.

Word 82

Bit	Function
15	0: Obsolete
14	1: NOP command is supported
13	1: Read Buffer command is supported
12	1: Write Buffer command is supported
11	0: Obsolete
10	1: Host Protected Area feature set is supported
9	1: Device Reset command is supported
8	1: Service interrupt is supported
7	1: Release interrupt is supported
6	1: Look-ahead is supported
5	1: Write cache is supported
4	0: Packet Command feature set is not supported
3	1: Power Management feature set is supported
2	1: Removable Media feature set is supported
1	1: Security Mode feature set is supported
0	1: SMART feature set is supported

Word 83

The values in this word should not be depended on by host implementers.

Bit	Function
15	0: Provides indications that the features/command sets supported words are not valid
14	1: Provides indications that the features/command sets supported words are valid
13-9	0: Reserved
8	1: Set-Max security extension supported
7	0: Reserved
6	1: SET FEATURES subcommand required to spin-up after power-up
5	1: Power-Up In Standby feature set supported
4	1: Removable Media Status feature set is supported
3	1: Advanced Power Management feature set is not supported
2	1: CFA feature set is not supported
1	1: Read DMA Queued and Write DMA Queued commands are supported
0	1: Download Microcode command is supported

Word 84

The values in this word should not be depended on by host implementers.

Bit	Function
15	0: Provides indications that the features/command sets supported words are valid
14	1: Provides indications that the features/command sets supported words are valid
13-2	0: Reserved
1	1: SMART self-test supported
0	1: SMART error logging supported

25. Words 85-87: Features/command sets enabled

Words 85, 86, and 87 indicate features/command sets enabled. The host can enable/disable the features or command set only if they are supported in Words 82-84.

Word 85

Bit	Function
15	0: Obsolete
14	0: NOP command is not enabled 1: NOP command is enabled
13	0: Read Buffer command is not enabled 1: Read Buffer command is enabled
12	0: Write Buffer command is not enabled 1: Write Buffer command is enabled
11	0: Obsolete
10	1: Host Protected Area feature set is not enabled
9	1: Device Reset command is enabled
8	1: Service interrupt is enabled
7	1: Release interrupt is enabled
6	0: Look-ahead is not enabled 1: Look-ahead is enabled
5	0: Write cache is not enabled 1: Write cache is enabled
4	0: Packet Command feature set is not enabled
3	0: Power Management feature set is not enabled 1: Power Management feature set is enabled
2	1: Removable Media feature set is enabled
1	0: Security Mode feature set has not been enabled via the Security Set Password command 1: Security Mode feature set has been enabled via the Security Set Password command
0	1: SMART feature set is enabled

Word 86

Bit	Function
15-9	0: Reserved
8	1: Set-Max security extension enabled
7-5	1: Reserved
4	1: Removable Media Status feature set is enabled
3	0: Advanced Power Management feature set is not enabled via the Set Features command 1: Advanced Power Management feature set is enabled via the Set Features command
2	1: CFA feature set is enabled
1	1: Read DMA Queued and Write DMA Queued commands are enabled
0	1: Download Microcode command is enabled

Word 87

The values in this word should not be depended on by host implementers.

Bit Function

- 15 0: Provides indications that the features/command sets supported words are valid
- 14 1: Provides indications that the features/command sets supported words are valid
- 13-2 0: Reserved
- 1 1: SMART self-test enabled
- 0 1: SMART error logging enabled

Word 88

Bit Function

- 15-13 Reserved
- 12 1: Ultra DMA mode-4 is selected
0: Ultra DMA mode-4 is not selected
- 11 1: Ultra DMA mode-3 is selected
0: Ultra DMA mode-3 is not selected
- 10 1: Ultra DMA mode-2 is selected
0: Ultra DMA mode-2 is not selected
- 9 1: Ultra DMA mode-1 is selected
0: Ultra DMA mode-1 is not selected
- 8 1: Ultra DMA mode-0 is selected
0: Ultra DMA mode-0 is not selected
- 7-5 Reserved
- 4 1: Ultra DMA mode-4 and below are supported
- 3 1: Ultra DMA mode-3 and below are supported
- 2 1: Ultra DMA mode-2 and below are supported
- 1 1: Ultra DMA mode-1 and below are supported
- 0 1: Ultra DMA mode-0 is supported

26. Word 89: Time required for Security erase unit completion

Word 89 specifies the time required for the Security Erase Unit command to complete.

Value	Time
0	Value Not Specified
1-254	(Value * 2) minutes
255	>508 minutes

27. Word 90: Time required for Enhanced security erase unit completion

Word 90 specifies the time required for the Enhanced Security Erase Unit command to complete.

Value	Time
0	Value Not Specified
1-254	(Value * 2) minutes
255	>508 minutes

28. Word 127: Removable Media Status Notification feature set support

Bit	Function
15-2	Reserved
1-0	00 Removable Media Status Notification feature set not supported
	01 Removable Media Status Notification feature set supported
	10 Reserved
	11 Reserved

29. Word 128: Security Status

Bit	Function
8	Security Level 1: Security mode is enabled and the security level is the maximum 0: Security mode is not enabled and the security level is the minimal
5	Enhanced security erase unit feature supported 1: Enhanced security erase unit feature set is supported
4	Expire 1: Security count has expired and Security Unlock and Security Erase Unit are command aborted until a power-on reset or hard reset
3	Freeze 1: Security is frozen
2	Lock 1: Security is locked
1	Enable/Disable 1: Security is enabled
0	Capability 1: Supports security mode feature set

30. Word 255: Integrity Word

Bit	Function
15-8	Checksum
7-0	Signature

6.1.5 Idle - E3H or 97H

Bit ->	7	6	5	4	3	2	1	0
Command (7)	E3H or 97H							
C/D/H (6)	X		Drive		X			
Cyl High (5)					X			
Cyl Low (4)					X			
Sec Num (3)					X			
Sec Cnt (2)	Timer Count (5msec increments)							
Feature (1)					X			

This command causes the SATA Disk Module to set BSY, enter the Idle Mode, clear BSY and generate an interrupt. If the sector count is non-zero, it is interpreted as a timer count with each count being 5 milliseconds and the automatic power down mode is enabled. If the sector count is zero and the automatic power down mode is also enabled, the timer count is set to 3, with each count being 5ms. Note that this time base (5msec) is different from the ATA specification.

6.1.6 Idle-Immediate - E1H or 95H

Bit ->	7	6	5	4	3	2	1	0
Command (7)	E1H or 95H							
C/D/H (6)	X		Drive		X			
Cyl High (5)					X			
Cyl Low (4)					X			
Sec Num (3)					X			
Sec Cnt (2)					X			
Feature (1)					X			

This command causes the SATA Disk Module to set BSY, enter the Idle Mode, clear BSY and generate an interrupt.

6.1.7 Initialize-Drive-Parameters - 91H

Bit ->	7	6	5	4	3	2	1	0
Command (7)	91H							
C/D/H (6)	X	0	X	Drive	Max Head (no. of heads-1)			
Cyl High (5)					X			
Cyl Low (4)					X			
Sec Num (3)					X			
Sec Cnt (2)	Number of Sectors							
Feature (1)					X			

This command enables the host to set the number of sectors per track and the number of heads per cylinder. Only the Sector Count and the Drive/Head registers are used by this command.

6.1.8 Read DMA – C8H or C9H

Bit ->	7	6	5	4	3	2	1	0
Command (7)	C8H or C9H							
C/D/H (6)	1	LBA	1	Drive	Head (LBA 27-24)			
Cyl High (5)	Cylinder High (LBA 23-16)							
Cyl Low (4)	Cylinder Low (LBA 15-8)							
Sec Num (3)	Sector Number (LBA 7-0)							
Sec Cnt (2)	Sector Count							
Feature (1)	X							

This command executes in a similar manner to the READ SECTOR (S) command except for the following:

- The host initializes the DMA channel prior to issuing the command;
- Data transfers are qualified by DMARQ and are performed by the DMA channel;
- The SATA Disk Module issues only one interrupt per command to indicate that data transfer has terminated and status is available.

During the DMA transfer phase of a READ DMA command, the SATA Disk Module shall provide status of the BSY bit or the DRQ bit until the command is completed. At command completion, the command block registers contain the cylinder, head and sector number (LBA) of the last sector read.

If an error occurs, the read terminates at the sector where the error occurred. The flawed data is pending in the sector buffer. Subsequent sectors are transferred only if the error was a correctable data error. All other errors cause Read-DMA to stop after transfer of the sector that contained the error.

For Ultra-DMA mode, if a CRC error is detected during transfer, the ICRC and ABRT bits of the Error register are set at the end of the command.

6.1.9 Read-Multiple – C4H

Bit ->	7	6	5	4	3	2	1	0
Command (7)	C4H							
C/D/H (6)	X	LBA	X	Drive	Head (LBA 27-24)			
Cyl High (5)	Cylinder High (LBA 23-16)							
Cyl Low (4)	Cylinder Low (LBA 15-8)							
Sec Num (3)	Sector Number (LBA 7-0)							
Sec Cnt (2)	Sector Count							
Feature (1)	X							

The Read- Multiple command is similar to the Read- Sector(s) command. Interrupts are not generated on every sector, but on the transfer of a block which contains the number of sectors defined by a Set-Multiple command.

Command execution is identical to the Read- Sectors operation except that the numbers of sectors defined by a Set-Multiple command are transferred without intervening interrupts. DRQ qualification of the transfer is required only at the start of the data block, not on each sector.

The block count of sectors to be transferred without intervening interrupts is programmed by the Set-Multiple Mode command, which must be executed prior to the Read-Multiple command. When the Read-Multiple command is issued, the Sector Count register contains the number of sectors (not the number of blocks or the block count) requested. If the number of requested sectors is not evenly divisible by the block count, as many full blocks as possible are transferred, followed by a final, partial block transfer.

The partial block transfer is for n sectors, where n = remainder (sector count/block count). If the Read-Multiple command is attempted before the Set-Multiple Mode command has been executed or when Read-Multiple commands are disabled, the Read-Multiple operation is rejected with an Aborted Command error. Disk errors encountered during Read-Multiple commands are posted at the beginning of the block or partial block transfer, but DRQ is still set and the data transfer will take place as it normally would, including transfer of corrupted data, if any.

Interrupts are generated when DRQ is set at the beginning of each block or partial block. The error reporting is the same as that on a Read-Sector(s) Command. This command reads from 1 to 256 sectors as specified in the Sector Count register. A sector counts of 0 requests 256 sectors. The transfer begins at the sector specified in the Sector Number register.

At command completion, the Command Block registers contain the cylinder, head and sector number of the last sector read. If an error occurs, the read terminates at the sector where the error occurred. The Command Block registers contain the cylinder, head and sector number of the sector where the error occurred. The flawed data is pending in the sector buffer.

Subsequent blocks or partial blocks are transferred only if the error was a correctable data error. All other errors cause the command to stop after transfer of the block which contained the error.

6.1.10 Read Sectors - 20H or 21H

Bit ->	7	6	5	4	3	2	1	0
Command (7)	20H or 21H							
C/D/H (6)	X	LBA	X	Drive	Head (LBA 27-24)			
Cyl High (5)	Cylinder High (LBA 23-16)							
Cyl Low (4)	Cylinder Low (LBA 15-8)							
Sec Num (3)	Sector Number (LBA 7-0)							
Sec Cnt (2)	Sector Count							
Feature (1)	X							

This command reads from 1 to 256 sectors as specified in the Sector Count register. A sectors count of 0 requests 256 sectors. The transfer begins at the sector specified in the Sector Number register. When this command is issued and after each sector of data (except the last one) has been read by the host, the SATA Disk Module sets BSY, puts the sector of data in the buffer, sets DRQ, clears BSY, and generates an interrupt. The host then reads the 512 bytes of data from the buffer.

At command completion, the Command Block registers contain the cylinder, head and sector number of the last sector read. If an error occurs, the read terminates at the sector where the error occurred. The Command Block registers contain the cylinder, head, and sector number of the sector where the error occurred. The flawed data is pending in the sector buffer.

6.1.11 Read Verify Sector(s) – 40H or 41H

Bit ->	7	6	5	4	3	2	1	0
Command (7)	40H or 41H							
C/D/H (6)	X	LBA	X	Drive	Head (LBA 27-24)			
Cyl High (5)	Cylinder High (LBA 23-16)							
Cyl Low (4)	Cylinder Low (LBA 15-8)							
Sec Num (3)	Sector Number (LBA 7-0)							
Sec Cnt (2)	Sector Count							
Feature (1)	X							

This command is identical to the Read- Sectors command, except that DRQ is never set and no data is transferred to the host. When the command is accepted, the SATA Disk Module sets BSY.

When the requested sectors have been verified, the SATA Disk Module clears BSY and generates an interrupt. Upon command completion, the Command Block registers contain the cylinder, head, and sector number of the last sector verified.

If an error occurs, the Verify terminates at the sector where the error occurs. The Command Block registers contain the cylinder, head and sector number of the sector where the error occurred. The Sector Count register contains the number of sectors not yet verified.

6.1.12 Recalibrate – 1XH

Bit ->	7	6	5	4	3	2	1	0
Command (7)	1XH							
C/D/H (6)	X	LBA	X	Drive	X			
Cyl High (5)	X							
Cyl Low (4)	X							
Sec Num (3)	X							
Sec Cnt (2)	X							
Feature (1)	X							

This command is effectively a no operation command to the SATA Disk Module and is provided for compatibility purposes.

6.1.13 Security-Disable-Password – F6H

Bit ->	7	6	5	4	3	2	1	0
Command (7)	F6H							
C/D/H (6)	X		Drive		X			
Cyl High (5)					X			
Cyl Low (4)					X			
Sec Num (3)					X			
Sec Cnt (2)					Config			
Feature (1)					Feature			

This command requests a transfer of a single sector of data from the host. Table 6-5 defines the content of this sector of information. If the password selected by Word 0 matches the password previously saved by the device, the device disables the lock mode. This command does not change the Master password that may be reactivated later by setting a User password.

Table 6-5: Security password data content

Word	Content
0	Control word: Bit 0: Identifier 0: Compare user password 1: Compare master password Bit 1-15: Reserved
1-16	Password (32 bytes)
17-256	Reserved

6.1.14 Security-Erase-Prepare – F3H

Bit ->	7	6	5	4	3	2	1	0
Command (7)	F3H							
C/D/H (6)	X		Drive		X			
Cyl High (5)					X			
Cyl Low (4)					X			
Sec Num (3)					X			
Sec Cnt (2)					Config			
Feature (1)					Feature			

This command is issued immediately before the Security-Erase-Unit command to enable device erasing and unlocking. This command prevents accidental erasure of the data in the flash media.

6.1.15 Security-Erase-Unit – F4H

Bit ->	7	6	5	4	3	2	1	0
Command (7)	F4H							
C/D/H (6)	X		Drive		X			
Cyl High (5)					X			
Cyl Low (4)					X			
Sec Num (3)					X			
Sec Cnt (2)					Config			
Feature (1)					Feature			

This command requests transfer of a single sector of data from the host. Table 6-5 defines the content of this sector of information. If the password does not match the password previously saved by the SATA Disk Module, the SATA Disk Module rejects the command with command aborted. The Security-Erase-Prepare command should be completed immediately prior to the Security-Erase-Unit command. If the SATA Disk Module receives a Security-Erase-Unit command without an immediately prior Security-Erase-Prepare command, the SATA Disk Module aborts the Security- Erase-Unit command.

6.1.16 Security-Freeze-Lock – F5H

Bit ->	7	6	5	4	3	2	1	0
Command (7)	F5H							
C/D/H (6)	X		Drive		X			
Cyl High (5)					X			
Cyl Low (4)					X			
Sec Num (3)					X			
Sec Cnt (2)					Config			
Feature (1)					Feature			

The Security-Freeze-Lock command sets the SATA Disk Module to Frozen mode. After command completion, any other commands that update the SATA Disk Module Lock mode are rejected. Frozen mode is disabled by power off or hardware reset. If Security-Freeze-Lock is issued when the SATA Disk Module is in Frozen mode, the command executes and the SATA Disk Module remains in Frozen mode. After command completion, the Sector Count Register shall be set to 0. Commands disabled by Security-Freeze-Lock are:

- Security-Set-Password
- Security-Unlock
- Security-Disable-Password
- Security-Erase-Unit

If security mode feature set is not supported, this command shall be handled as Wear- Level command.

6.1.17 Security-Set-Password - F1H

Bit ->	7	6	5	4	3	2	1	0
Command (7)	F1H							
C/D/H (6)		X		Drive			X	
Cyl High (5)					X			
Cyl Low (4)					X			
Sec Num (3)					X			
Sec Cnt (2)						Config		
Feature (1)								Feature

This command requests a transfer of a single sector of data from the host. Table 6-6 defines the content of the sector of information. The data transferred controls the function of this command.

Table 6-6: Security password data content

Word	Content
0	Control word: Bit 0: Identifier 0: Compare user password 1: Compare master password Bit 1-15: Reserved
1-16	Password (32 bytes)
17-256	Reserved

Table 6-7: Identifier and security level bit interaction

Identifier	Level	Command Result
User	High	The password supplied with the command shall be saved as the new User password. The lock mode shall be enabled from the next power-on or hardware reset. The SATA Disk Module shall then be unlocked by either the User password or the previously set Master password.
User	Maximum	The password supplied with the command shall be saved as the new user password. The lock mode shall be enabled from the next power-on reset or hardware reset. The SATA Disk Module shall then be unlocked by only the User password. The Master password previously set is still stored in the SATA Disk Module shall not be used to unlock the SATA Disk Module.
User	High or Maximum	This combination shall set a Master password but shall not enable or disable the Lock mode. The security level is not changed.

6.1.18 Security-Unlock – F2H

Bit ->	7	6	5	4	3	2	1	0
Command (7)	F2H							
C/D/H (6)		X		Drive			X	
Cyl High (5)	X							
Cyl Low (4)	X							
Sec Num (3)	X							
Sec Cnt (2)	Config							
Feature (1)	Feature							

This command requests transfer of a single sector of data from the host. Table 6-5 defines the content of this sector of information. If the identifier bit is set to Master and the device is in high security level, then the password supplied shall be compared with the stored Master password. If the device is in the maximum security level, then the unlock command shall be rejected. If the identifier bit is set to user, then the device compares the supplied password with the stored User password. If the password compare fails then the device returns command aborted to the host and decrements the unlock counter. This counter is initially set to five and is decremented for each password mismatch when Security-Unlock is issued and the device is locked. Once this counter reaches zero, the Security-Unlock and Security-Erase-Unit commands are command aborted until after a power-on reset or a hardware reset is received. Security-Unlock commands issued when the device is unlocked have no effect on the unlock counter.

6.1.19 Seek – 7XH

Bit ->	7	6	5	4	3	2	1	0
Command (7)	7XH							
C/D/H (6)	X	LBA	X	Drive		Head (LBA 27-24)		
Cyl High (5)	Cylinder High (LBA 23-16)							
Cyl Low (4)	Cylinder Low (LBA 15-8)							
Sec Num (3)	Sector Number (LBA 7-0)							
Sec Cnt (2)	Sector Count							
Feature (1)	X							

This command is effectively a NOP command to the SATA Disk Module although it does perform a range check of cylinder and head or LBA address and returns an error if the address is out of range.

6.1.20 Set-Features – EFH

Bit ->	7	6	5	4	3	2	1	0
Command (7)	EFH							
C/D/H (6)		X		Drive			X	
Cyl High (5)					X			
Cyl Low (4)					X			
Sec Num (3)					X			
Sec Cnt (2)						Config		
Feature (1)								Feature

This command is used by the host to establish or select certain features. Table 6-8 defines all features that are supported.

Table 6-8: Supported Features

Feature	Operation
02H	Enable write cache.
03H	Set transfer mode based on value in Sector Count register.
55H	Disable Read Look Ahead.
82H	Disable write cache.
AAH	Enable Read Look Ahead.

Features 02H and 82H allow the host to enable or disable write cache in the SATA Disk Module that implements write cache. When the subcommand Disable-Write-Cache is issued, the SATA Disk Module should initiate the sequence to flush cache to non-volatile memory before command completion.

Feature 03H allows the host to select the transfer mode by specifying a value in the Sector Count register. The upper 5 bits define the type of transfer and the low order 3 bits encode the mode value. One PIO mode is selected at all times. The host may change the selected modes by the Set-Features command.

Feature 55H is the default feature for the SATA Disk Module. Therefore, the host does not have to issue Set-Features command with this feature unless it is necessary for compatibility reasons.

Table 6-6: Transfer mode values

Mode	Bits [7:3]	Bits [2:0]
PIO default mode	00000b	000b
PIO default mode, disable IORDY	00000b	001b
PIO flow control transfer mode	00001b	mode ¹
Multiword DMA mode	00100b	mode ¹
Ultra DMA mode	01000b	mode ¹
Reserved	Other	N/A

1. Mode = transfer mode number, all other values are not valid

6.1.21 SMART – B0H

SMART Command signature is defined as cylinder being C2H to F4H. The feature register will indicate the subcommand as listed below. If the Features register contains an unsupported value, the Aborted Command error is returned. If the SMART function is disabled, any subcommand other than SMART ENABLE OPERATIONS results in the Aborted Command error.

6.1.21.1 SMART Return Status – DAH

Bit ->	7	6	5	4	3	2	1	0
Command (7)	B0H							
C/D/H (6)	X		Drive		X			
Cyl High (5)	C2H							
Cyl Low (4)	4FH							
Sec Num (3)	X							
Sec Cnt (2)	X							
Feature (1)	DAH							

This Command is used to communicate the reliability status of the device to the host at the host's request. If the device has not detected a threshold exceeded condition, the device sets the LBA Mid register to 4FH and the LBA High register to C2H. If the device has detected a threshold exceeded condition, the device sets the LBA Mid register to F4H and the LBA High register to 2CH. In the current implementation, the only threshold checked is that if a fatal error has occurred.

6.1.21.5 SMART Execute Offline – D4H

Bit ->	7	6	5	4	3	2	1	0
Command (7)	B0H							
C/D/H (6)	X		Drive		X			
Cyl High (5)	C2H							
Cyl Low (4)	4FH							
Sec Num (3)	X							
Sec Cnt (2)	X							
Feature (1)	D4H							

This Command causes the device to immediately initiate the optional set of activities that collect SMART data in an off-line mode and the save this data to the device's memory. This data is not retained across resets and a new command must be executed to recollect data. The collected data should be read by a subsequent SMART Read Data (D0H) command.

6.1.21.6 SMART Read Data – D0H

Bit ->	7	6	5	4	3	2	1	0
Command (7)	B0H							
C/D/H (6)	X			Drive	X			
Cyl High (5)	C2H							
Cyl Low (4)	4FH							
Sec Num (3)	X							
Sec Cnt (2)	X							
Feature (1)	D0H							

This Command returns the Device SMART data structure to the host. This command must be preceded by the SMART Execute Offline command with an appropriate subcommand listed above. The returned data will depend on the requested subcommand.

All returned data comply with the SMART data structure as specified in the SATA spec. Bytes 0 to 361 of the structure returns specific data that depends of the requested subcommand. Bytes 362 to 385 are standard values as defined in the ATA spec. bytes 386 to 510 returns specific data common to all subcommands. Byte 511 is the 2's complement checksum of all bytes in the data structure.

Byte	Description
0-1	Data Structure Revision Number
2-13	1 st Attribute data
14-361	2 nd -30 th Individual Attribute Data
362	Off-line Data Collection Status
363	Reserved
364-365	Total Time in Seconds to Complete Off-line Data Collection
366	Reserved
367	Off-line Data Collection Capability
368-369	SMART Capability
370-510	Reserved
511	Data Structure Checksum

Byte 2-361: Individual Attribute Data

Byte	Description
0	Attribute ID
1-2	Status Flag (0x0002)
3	Attribute Value (0x64)
4-11	Vendor Specific

SATA Disk Module 3 Series

FMS-SDMxxxxKBANS-XTX



ID	Description	Detail Information	
		Byte	Description
E5h	Halt System ID, Flash ID	0	Halt System ID
		1	Flash ID (byte 1)
		2	Flash ID (byte 2)
		3	Flash ID (byte 3)
		4	Flash ID (byte 4)
		5	Flash ID (byte 5)
		6	Flash ID (byte 6)
		7	Flash ID (byte 7)
E8h	Firmware version information	0	Year (High Byte, ASCII)
		1	Year (Low Byte, ASCII)
		2	Month (High Byte, ASCII)
		3	Month (Low Byte, ASCII)
		4	Day (High Byte, ASCII)
		5	Day (Low Byte, ASCII)
		6	Channels (binary)
		7	Banks (binary)
E9h	ECC Fail Record	0	ECC fail number
		1	Row address 3
		2	Row address 2
		3	Row address 1
		4	Channel number of last ECC fail
		5	Bank number of last ECC fail
		6	Reserved
		7	Reserved
EAh	Average Erase Count, Max Erase Count	0	Average Erase Count (High Byte)
		1	Average Erase Count
		2	Average Erase Count (Low Byte)
		3	Max Erase Count (High Byte)
		4	Max Erase Count
		5	Max Erase Count (Low Byte)
		6	Reserved
		7	Reserved
EBh	Good Block Count, System Block Count	0	Good Block Count (High Byte)
		1	Good Block Count
		2	Good Block Count (Low Byte)
		3	System(Free) Block Count (High Byte)
		4	System(Free) Block Count
		5	System(Free) Block Count (Low Byte)
		6	Reserved
		7	Reserved
ECh-FFh	Reserved		

Offline Data Collection Status (byte 362)

The offline data collection status byte indicates whether SMART data collection was successful or not. The host should check this value in the returned data structure before proceeding with interpretation of vendor specific data bytes. The follow are possible status values.

Value	Definition
00H	Offline data collection activity was never started.
02H	Offline data collection activity was completed without error.
04H	Offline data collection activity was suspended host.
05H	Offline data collection activity was aborted by host.
06H	Offline data collection activity was aborted by device.

6.1.21.7 SMART Enable/Disable Auto Off-line – DBH

Bit ->	7	6	5	4	3	2	1	0
Command (7)	B0H							
C/D/H (6)	X		Drive		X			
Cyl High (5)	C2H							
Cyl Low (4)	4FH							
Sec Num (3)	X							
Sec Cnt (2)	F8h or 00h							
Feature (1)	DBH							

Enables (when Sector Count Register = “F8h”) or disables (Sector Count Register = “00h”) the automatic off-line data collection function.

The automatic collection is disabled if a value of “00h” is set in the Sector Count register before a subcommand is issued. If automatic collection is disabled, the drive can still save attribute information during normal operation, such as during the power-on/off sequence or error correction sequence.

The automatic collection function is enabled if a value of “F8h” is set in the Sector Count register before the command is issued. Values other than “00h” and “F8h” are vendor-specific.

6.1.22 Standby – E2H or 96H

Bit ->	7	6	5	4	3	2	1	0
Command (7)	E2H or 96H							
C/D/H (6)	X		Drive		X			
Cyl High (5)	X							
Cyl Low (4)	X							
Sec Num (3)	X							
Sec Cnt (2)	X							
Feature (1)	X							

This command causes the SATA Disk Module to set BSY, enter the Sleep mode (which corresponds to the SATA “Standby” Mode), clear BSY and return the interrupt immediately. Recovery from Sleep mode is accomplished by simply issuing another command (a reset is not required).

6.1.23 Standby-Immediate – E0H or 94H

Bit ->	7	6	5	4	3	2	1	0	
Command (7)	E0H or 94H								
C/D/H (6)		X		Drive			X		
Cyl High (5)					X				
Cyl Low (4)					X				
Sec Num (3)					X				
Sec Cnt (2)					X				
Feature (1)					X				

This command causes the SATA Disk Module to set BSY, enter the Sleep mode (which corresponds to the SATA “Standby” Mode), clear BSY and return the interrupt immediately. Recovery from Sleep mode is accomplished by simply issuing another command (a reset is not required).

6.1.24 Write-DMA – CAH or CBH

Bit ->	7	6	5	4	3	2	1	0
Command (7)	CAH or CBH							
C/D/H (6)	1	LBA	1	Drive	Head (LBA 27-24)			
Cyl High (5)	Cylinder High (LBA 23-16)							
Cyl Low (4)	Cylinder Low (LBA 15-8)							
Sec Num (3)	Sector Number (LBA 7-0)							
Sec Cnt (2)	Sector Count							
Feature (1)	X							

This command executes in a similar manner to Write-RITE Sector(s) except for the following:

- The host initializes the DMA channel prior to issuing the command
- Data transfers are qualified by DMARQ and are performed by the DMA channel
- The SATA Disk Module issues only one interrupt per command to indicate that data transfer has terminated and status is available.

During the execution of a Write-RITE DMA command, the SATA Disk Module shall provide status of the BSY bit or the DRQ bit until the command is completed. At command completion, the command block registers contain the cylinder, head and sector number (LBA) of the last sector read.

If an error occurs after the attempted write of a transferred sector, the command is terminated and subsequent blocks are not transferred. The command block registers contain the cylinder, head and sector number of the sector where the error occurred and the Sector Count register contains the residual number of sectors for successful completion of the command.

For Ultra-DMA mode, if a CRC error is detected during transfer, the ICRC and ABRT bits of the Error register are set at the end of the command.

6.1.25 Write-Multiple - C5H

Bit ->	7	6	5	4	3	2	1	0
Command (7)	CAH or CBH							
C/D/H (6)	1	LBA	1	Drive	Head (LBA 27-24)			
Cyl High (5)	Cylinder High (LBA 23-16)							
Cyl Low (4)	Cylinder Low (LBA 15-8)							
Sec Num (3)	Sector Number (LBA 7-0)							
Sec Cnt (2)	Sector Count							
Feature (1)	X							

Note: The current revision of the SATA Disk Module can support up to a block count of 1 as indicated in the Identify Drive Command information.

This command is similar to the Write-Sectors command. The SATA Disk Module sets BSY within 400 ns of accepting the command. Interrupts are not presented on each sector but on the transfer of a block which contains the number of sectors defined by Set-Multiple. Command execution is identical to the Write-Sectors operation except that the number of sectors defined by the Set-Multiple command is transferred without intervening interrupts.

DRQ qualification of the transfer is required only at the start of the data block, not on each sector. The block count of sectors to be transferred without intervening interrupts is programmed by the Set-Multiple Mode command, which must be executed prior to the Write-Multiple command.

When the Write-Multiple command is issued, the Sector Count register contains the number of sectors (not the number of blocks or the block count) requested. If the number of requested sectors is not evenly divisible by the sector/block, as many full blocks as possible are transferred, followed by a final, partial block transfer. The partial block transfer is for n sectors, where: $n = \text{remainder}(\text{sector count/block count})$. If the Write-Multiple command is attempted before the Set-Multiple-Mode command has been executed or when Write-Multiple commands are disabled, the Write-Multiple operation will be rejected with an aborted command error.

Errors encountered during Write-Multiple commands are posted after the attempted writes of the block or partial block transferred. The Write command ends with the sector in error, even if it is in the middle of a block. Subsequent blocks are not transferred in the event of an error. Interrupts are generated when DRQ is set at the beginning of each block or partial block.

The Command Block registers contain the cylinder, head and sector number of the sector where the error occurred and the Sector Count register contains the residual number of sectors that need to be transferred for successful completion of the command, e.g. each block has 4 sectors, a request for 8 sectors is issued and an error occurs on the third sector. The Sector Count register contains 6 and the address is that of the third sector.

6.1.26 Write-Sector(s) - 30H or 31H

Bit ->	7	6	5	4	3	2	1	0
Command (7)	30H or 31H							
C/D/H (6)	X	LBA	X	Drive	Head (LBA 27-24)			
Cyl High (5)	Cylinder High (LBA 23-16)							
Cyl Low (4)	Cylinder Low (LBA 15-8)							
Sec Num (3)	Sector Number (LBA 7-0)							
Sec Cnt (2)	Sector Count							
Feature (1)	X							

This command writes from 1 to 256 sectors as specified in the Sector Count register. A sector count of zero requests 256 sectors. The transfer begins at the sector specified in the Sector Number register.

When this command is accepted, the SATA Disk Module sets BSY, then sets DRQ and clears BSY, then waits for the host to fill the sector buffer with the data to be written. No interrupt is generated to start the first host transfer operation. No data should be transferred by the host until BSY has been cleared by the host. For multiple sectors, after the first sector of data is in the buffer, BSY will be set and DRQ will be cleared. After the next buffer is ready for data, BSY is cleared, DRQ is set and an interrupt is generated. When the final sector of data is transferred, BSY is set and DRQ is cleared. It will remain in this state until the command is completed at which time BSY is cleared and an interrupt is generated. If an error occurs during a write of more than one sector, writing terminates at the sector where the error occurs. The Command Block registers contain the cylinder, head and sector number of the sector where the error occurred. The host may then read the command block to determine what error has occurred, and on which sector.

6.2 Error Posting

The following table summarizes the valid status and error values for the SATA command set.

TABLE 6-1: Error and Status Register

Command	Error Register					Status Register				
	BBK	UNC	IDNF	ABRT	AMNF	RDY	DWF	DSC	CORR	ERR
Check-Power-Mode				V		V	V	V		V
Execute-Drive-Diagnostic						V		V		V
Identify-Drive				V		V	V	V		V
Idle				V		V	V	V		V
Idle-Immediate				V		V	V	V		V
Initialize-Drive-Parameters						V		V		V
Read DMA	V	V	V	V	V	V	V	V	V	V
Read-Multiple	V	V	V	V	V	V	V	V	V	V
Read-Sector(s)	V	V	V	V	V	V	V	V	V	V
Read-Verify-Sector(s)	V	V	V	V	V	V	V	V	V	V
Recalibrate				V		V	V	V		V
Security-Disable-Password				V		V	V	V		V
Security-Erase-Prepare				V		V	V	V		V
Security-Erase-Unit				V		V	V	V		V
Security-Freeze-Lock				V		V	V	V		V
Security-Set-Password				V		V	V	V		V
Security-Unlock				V		V	V	V		V
Seek			V	V		V	V	V		V
Set-Features				V		V	V	V		V
Set-Multiple-Mode				V		V	V	V		V
Set-Sleep-Mode				V		V	V	V		V
SMART			V	V		V	V	V		V
Standby				V		V	V	V		V
Standby-Immediate				V		V	V	V		V
Write DMA	V		V	V	V	V	V	V		V
Write-Multiple	V		V	V	V	V	V	V		V
Write-Sector(s)	V		V	V	V	V	V	V		V
Invalid-Command-Code				V		V	V	V		V

V = valid on this command

7. Electrical Specification

Caution: Absolute Maximum Stress Ratings – Applied conditions greater than those listed under “Absolute Maximum Stress Ratings” may cause permanent damage to the device. This is a stress rating only and functional operation of the device at these conditions or conditions greater than those defined in the operational sections of this data sheet is not implied. Exposure to absolute maximum stress rating conditions may affect device reliability.

Table 7-1: Operating range

Range	Ambient Temperature	5V
Commercial	0°C to +70°C	4.5-5.5V
Industrial	-40°C to +85°C	

Table 7-2: Absolute maximum power pin stress ratings

Parameter	Symbol	Conditions
Input Power	V _{DD}	-0.3V min to 6.5V max
Voltage on any flash media interface pin with respect to GND	V	-0.5V min to V _{DD} + 0.5V max

Table 7-3: Recommended system power-up timing

Symbol	Parameter	Typical	Maximum	Units
TPU-READY ¹	Host Power-up/Reset to Ready Operation	200	1000	ms
TPU-WRITE ¹	Host Power-up/Reset to Write Operation	200	1000	ms

1. This parameter is measured only for initial qualification and after a design or process change that could affect this parameter.

8. Environmental Specifications

8.1 Environments

Environmental specification of the SATA Disk Module series follows the MIL-STD-810F standard as shown in Table 8-1.

Table 8-1: Environmental specifications

Environment		Specification
Temperature	Operation	0°C to 70°C (standard temperature); -40°C to 85°C (Industrial temperature)
	Storage	-40°C to 100°C
Vibration		Sine wave: 5~55~5 Hz (X, Y, Z) Random: 10-2000 Hz, 16.3 G (X, Y, Z)
Operating Shock		50(G), 11(ms), half-sine wave
Non-Operating Shock		1500(G), 0.5(ms), half-sine wave
Humidity		10~95% R.H, 30(°C) max. wet bulb temp., operating

8.2 Mean Time Between Failures (MTBF)

Mean Time Between Failures (MTBF) is predicted based on reliability data for the individual components in the SDM drive. Based on provided component data, SATA Disk Module is rated at more than 2,000,000 hours.

8.3 Certification and Compliance

The SDM complies with the following standards:

- CE – EN55022/55024
- FCC 47CFR Part15 Class B
- RoHS
- MIL-STD-810F
- SATA II (SATA Rev. 2.5)
- Up to ATA/ATAPI-7 (including S.M.A.R.T.)

9. Physical Characteristics

9.1 Dimensions

9.1.1 Power Cable Type

FIGURE 9-1: Physical dimensions

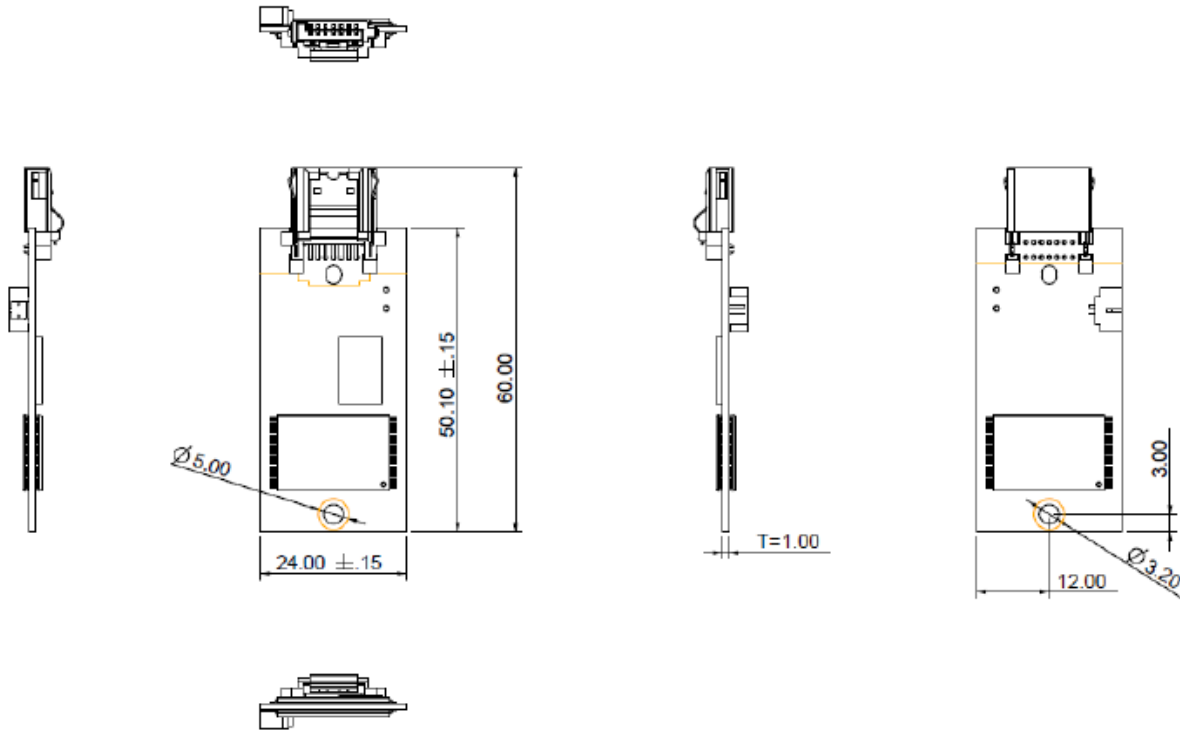

Units in mm
Tolerance: ± 0.25

SATA Disk Module 3 Series

FMS-SDMxxxxKBANS-XTX



9.1.2 Power Cable-less Type

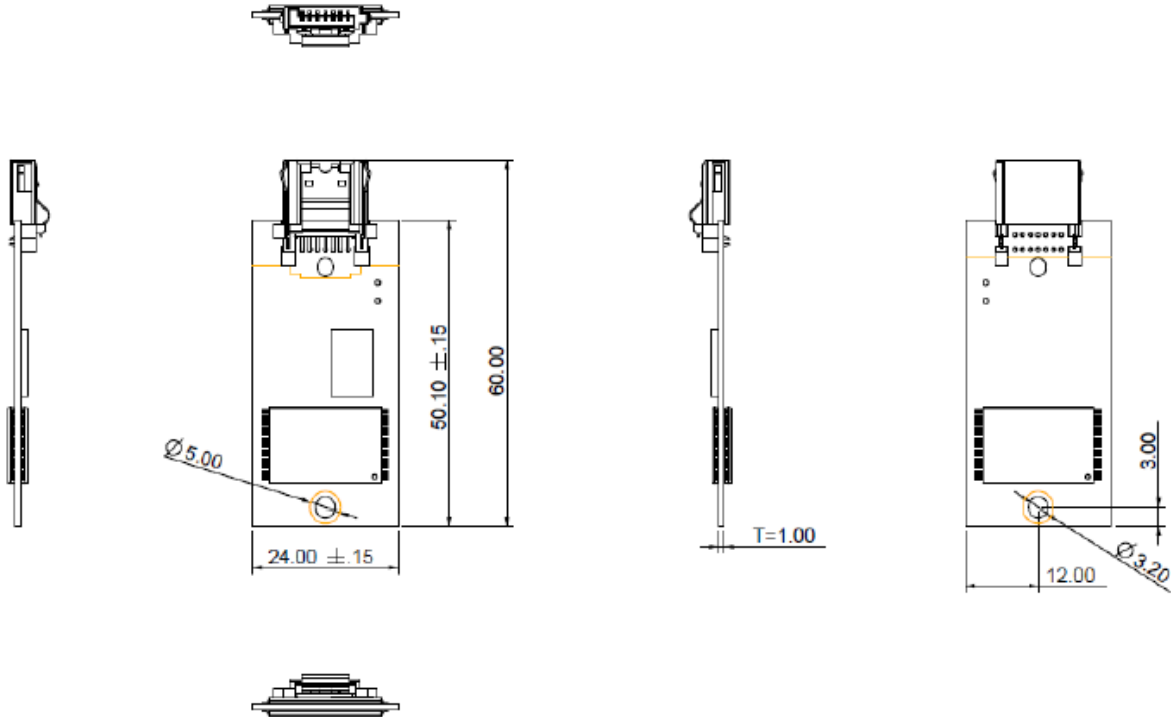

Units in mm
Tolerance: ± 0.25

10. Product Ordering Information

10.1 Product Code Designations

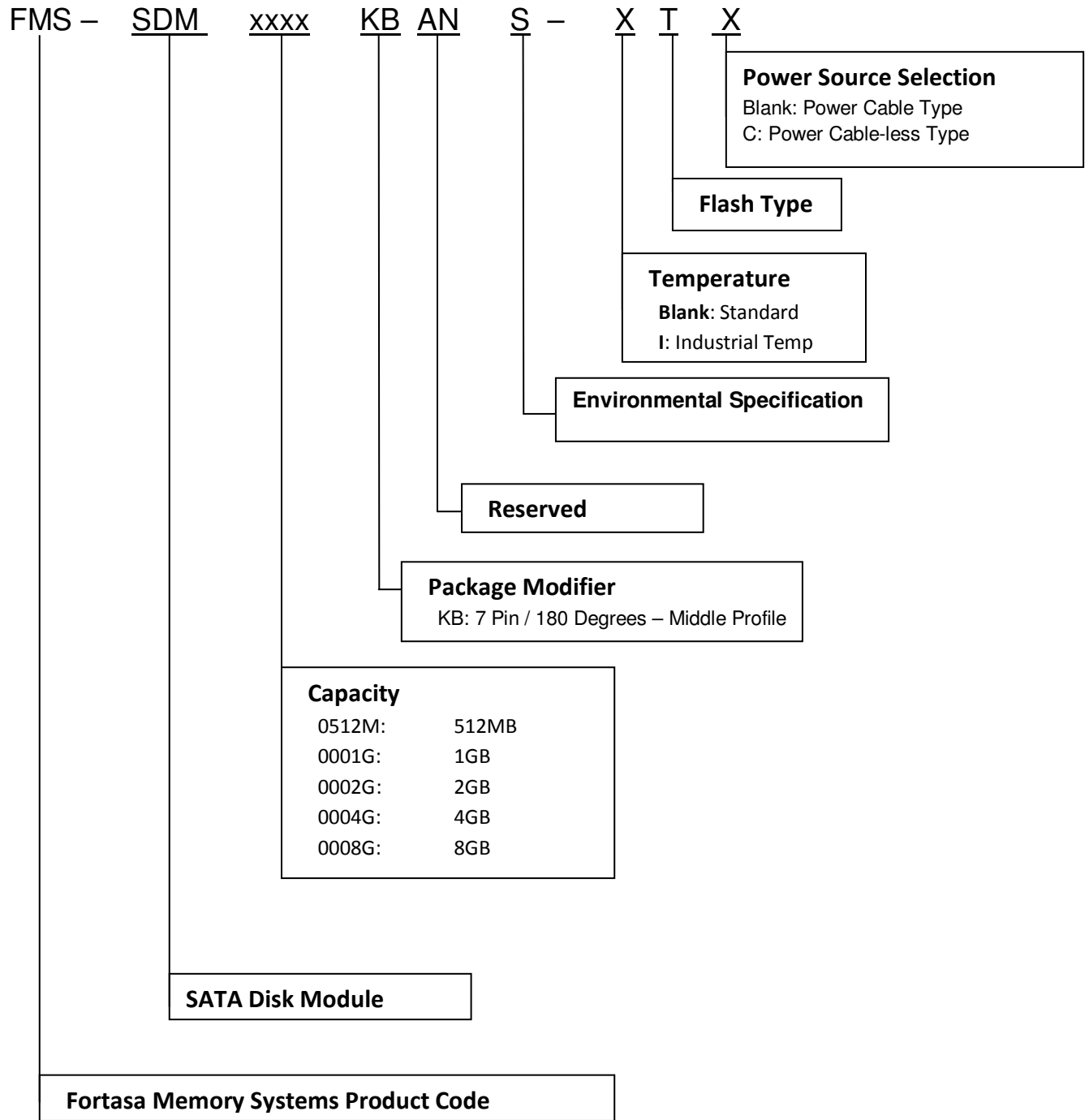

10.2 Valid Combinations

7P/180D: Power Cable Type

Standard Temperature		Industrial Temperature	
Capacity	Model Number	Capacity	Model Number
512MB	FMS-SDM512MKBANS-T	512MB	FMS-SDM512MKBANS-IT
1GB	FMS-SDM001GKBANS-T	1GB	FMS-SDM001GKBANS-IT
2GB	FMS-SDM002GKBANS-T	2GB	FMS-SDM002GKBANS-IT
4GB	FMS-SDM004GKBANS-T	4GB	FMS-SDM004GKBANS-IT
8GB	FMS-SDM008GKBANS-T	8GB	FMS-SDM008GKBANS-IT

Note: Valid combinations are those products in mass production or will be in mass production. Consult your Fortasa sales representative to confirm availability of valid combinations and to determine availability of new combinations.

7P/180D: Power Cable-Less Type

Standard Temperature		Industrial Temperature	
Capacity	Model Number	Capacity	Model Number
512MB	FMS-SDM512MKBANS-TC	512MB	FMS-SDM512MKBANS-ITC
1GB	FMS-SDM001GKBANS-TC	1GB	FMS-SDM001GKBANS-ITC
2GB	FMS-SDM002GKBANS-TC	2GB	FMS-SDM002GKBANS-ITC
4GB	FMS-SDM004GKBANS-TC	4GB	FMS-SDM004GKBANS-ITC
8GB	FMS-SDM008GKBANS-TC	8GB	FMS-SDM008GKBANS-ITC

Note: Valid combinations are those products in mass production or will be in mass production. Consult your Fortasa sales representative to confirm availability of valid combinations and to determine availability of new combinations.



11. Revision History

Revision	Date	Description	Comments
1.0	06/22/2011	Initial Release	
1.1	07/18/2011	Updated Power Consumption Data	