

SATA DISK CHIP DESIGN GUIDE

Application Note

August 1, 2011
Revision 1.1

*This Application Note Describes the Design Considerations
for Integrating SATA Disk Chip product*

***Please Contact Fortasa Sales for Any Additional Technical
Information About Fortasa Products***



4151 Middlefield Road
2nd Floor
Palo Alto, CA 94303 USA
888-367-8588
www.fortasa.com

SATA Disk Chip Design Guide

Introduction

Fortasa's SATA-Disk Chip (SDC) is an embedded flash system offering exceptional reliability. The SDC consists of a built-Flash controller and Flash memory device(s) packaged in either the standard 32-pin DIP or the 18-pin DIP package for easy, reliable and economical mounting to a system board.

There are two types of connectors for SDC: SDC (FMS-SDCxxx5QANS) with 32-pin and SDC (FMS-SDCxxx7QANS) with 18-pin connector respectively.

PIN ASSIGNMENTS

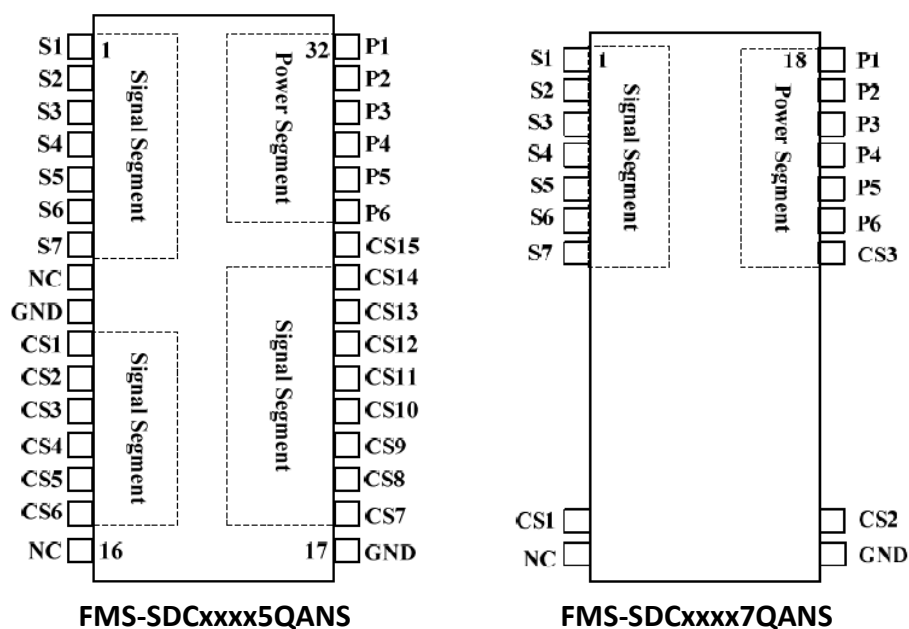

Signal Description

P1- P6 – Used to connect to power supply of 3.3 volts as the power segment.

S1 - S7 – This is a bi-directional data bus between the Host System and the SDC.

For FMS-SDCxxx5QANS

CS1 - CS5, CS8 - CS14– Reserved, Do Not Connect

CS6– Used to indicate serial ATA physical layer communication.

CS7– Used to indicate that SDC is active and usually connected to a LED indicator on the system to report activity.

CS15– Used to protect the SDC from being written. When WP# pin is low, the SDC is write-protected to prohibit any inadvertent writes.

SATA Disk Chip Design Guide

Application Note



For FMS-SDCxxx7QANS

CS1– Used to indicate serial ATA physical layer communication.

CS2– Used to indicate that SDC is active and usually connected to a LED indicator on the system to report activity.

CS3– Used to protect the SDC from being written. When WP# pin is low, the SDC is write-protected to prohibit any inadvertent writes.

Reference Schematics

For FMS-SDCxxx5QANS

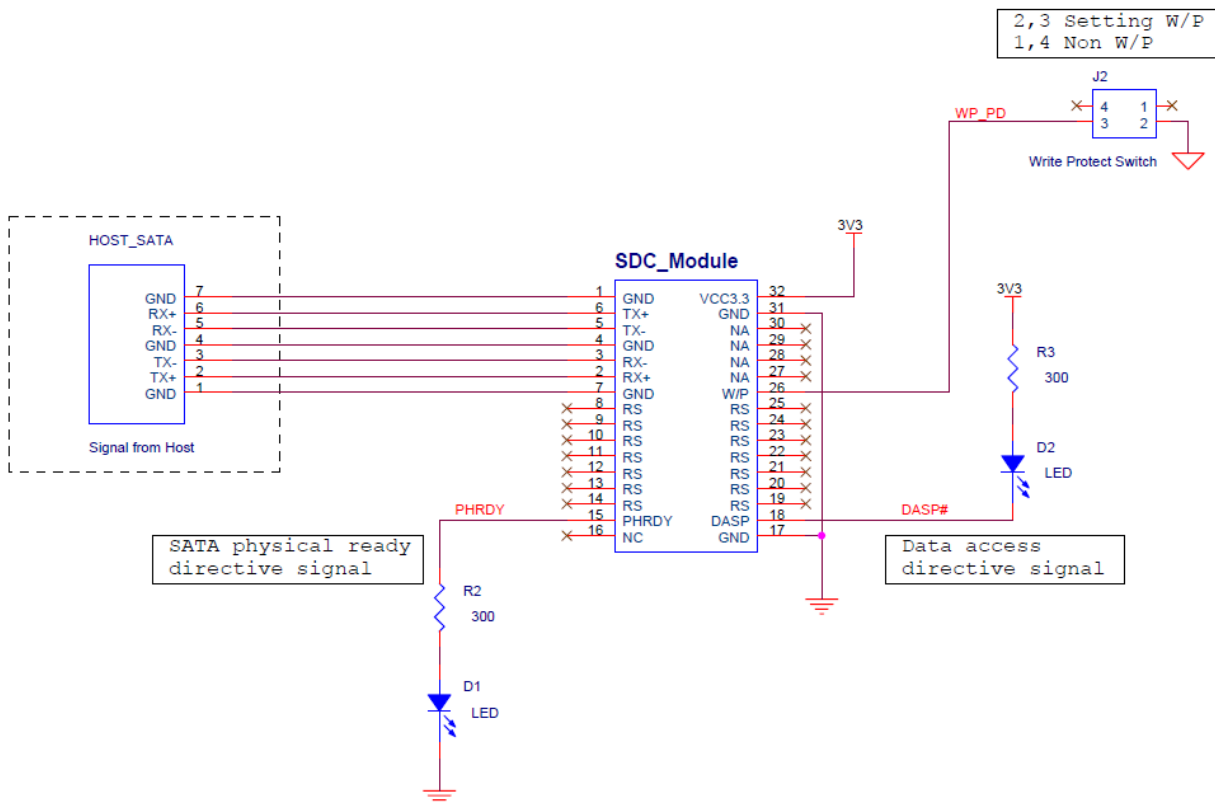

SATA Disk Chip Design Guide

Application Note



For FMS-SDCxxx7QANS

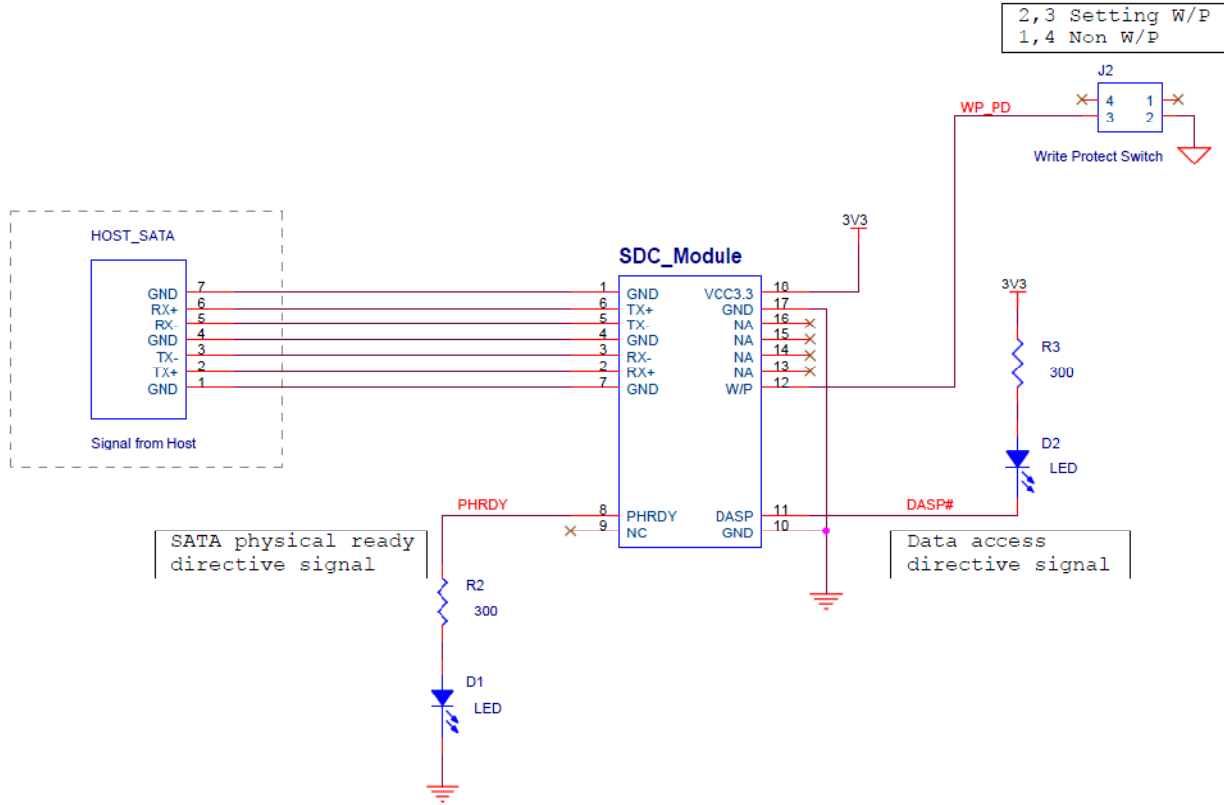

Revision History

Revision	Date	Description	Comments
1.0	2/18/2011	Initial Release	
1.1	8/1/2011	Corrected Reference Schematics	

Copyright © 2011 Fortasa Memory Systems, Inc. All Rights Reserved.
Information in this document is subject to change without prior notice.
Fortasa and the Fortasa logo are trademarks or registered trademarks of
Fortasa Memory Systems, Inc.

Other brands, names, trademarks or registered trademarks may be claimed as the property of
their respective owners.