

RoHS Compliant

ATA Disk Module 5 Series

Datasheet for Standard ADM 5 (40P/180D)

October 18, 2016

Revision 1.2

***This Specification Describes the Features and Capabilities of
the Standard and Industrial Temperature
ATA Disk Modules***

***Please Contact Fortasa Memory Systems Sales for any
Custom Features Required For Your Specific Application***



1111 Triton Drive
Suite 100
Foster City, CA 94404 USA
888-367-8588
www.fortasa.com

Features:

- **Standard ATA/IDE Bus Interface**
 - ATA command set compatible
 - ATA operating mode support for up to:
 - PIO Mode-4
 - Multiword DMA Mode-2
 - Ultra DMA Mode-6
- **Connector Type**
 - 40-pin standard female connector
- **Form Factor**
 - Dimension: 50.93 x 25.95 x 6.00 (unit:mm)
- **Low power consumption (typical)**
 - Supply voltage: 3.3V & 5V
 - Active mode: 280 mA (3.3V/5.0V)
 - Sleep mode: 15mA (3.3V/5.0V)
- **Performance**
 - Sustained read: up to 75 MB/sec
 - Sustained write: up to 65 MB/sec
- **Capacity**
 - 128, 256, 512 MB
 - 1, 2, 4, 8 16, 32 GB
- **NAND flash type: SLC**
- **Superior Reliability Through Built-in Hardware ECC**
 - Corrects up to 72 random single-bit errors per 1Kbyte sector
- **Temperature ranges**
 - Operation:
 - Standard Temperature: 0°C to 70°C
 - Industrial Temperature: -40°C to 85°C
 - Storage: -40°C to 100°C
- **Flash management**
 - Intelligent endurance design
 - Advanced wear-leveling algorithms*
 - S.M.A.R.T. Technology*
 - Enhanced Data Integrity*
 - Intelligent power failure recovery
- **RoHS compliant**



Table of Contents

1. General Description	4
2. Functional Block.....	4
3. Pin Assignments.....	5
4. Capacity Specification	6
4.1 Performance Specification	6
4.2 Environmental Specifications.....	7
5. Flash Management	7
5.1 Intelligent Flash Controller Features.....	7
5.1.1 Advanced wear-leveling algorithms.....	7
5.1.2 S.M.A.R.T. technology	7
5.1.3 Built-in hardware ECC.....	7
5.1.4 Enhanced data integrity	8
5.2 Intelligent Power Failure Recovery.....	8
6. Software Interface.....	9
6.1 Command Set.....	9
7. Electrical Specification	10
8. Physical Characteristics	11
8.1 Dimensions.....	11
9. Product Ordering Information.....	12
9.1 Product Code Designations	12
9.2 Valid Combinations.....	13
9.2.1 Standard Temperature	13
9.2.2 Industrial Temperature	13
10. Revision History	14

1. General Description

Fortasa’s ATA-Disk Module is a high-performance, embedded flash drive designed to replace the conventional IDE hard disk drive. The ADMs can be plugged into a standard IDE connector commonly found in desktops, IT-STB, industrial PCs and thin client systems. Fortasa’s ADM SSD has a built-in microcontroller with file management firmware that communicates with the ATA standard interfaces. No additional or proprietary host software is required.

Well suited for embedded flash storage applications by offering new and expanded functionalities as well as more cost-effective designs, better performance and increased reliability, ADM is designed to work at either 5 or 3.3 Volts, supports the standard ATA/IDE protocol for up to PIO Mode-4, Multiword DMA Mode-2 and Ultra DMA Mode-6 interfaces, and uses the standard ATA driver complying with all major operating systems such as Microsoft’s Windows series, Mac OS, and Unix variants.

Featuring technologies as Advanced Wear-leveling algorithms, S.M.A.R.T, Enhanced Data Integrity, Intelligent Power Failure Recovery, Fortasa’s ADM assures users of a versatile device on data storage.

2. Functional Block

The ATA Disk Module includes a controller and flash media, as well as the ATA standard interface. Figure 2-1 shows the functional block diagram.

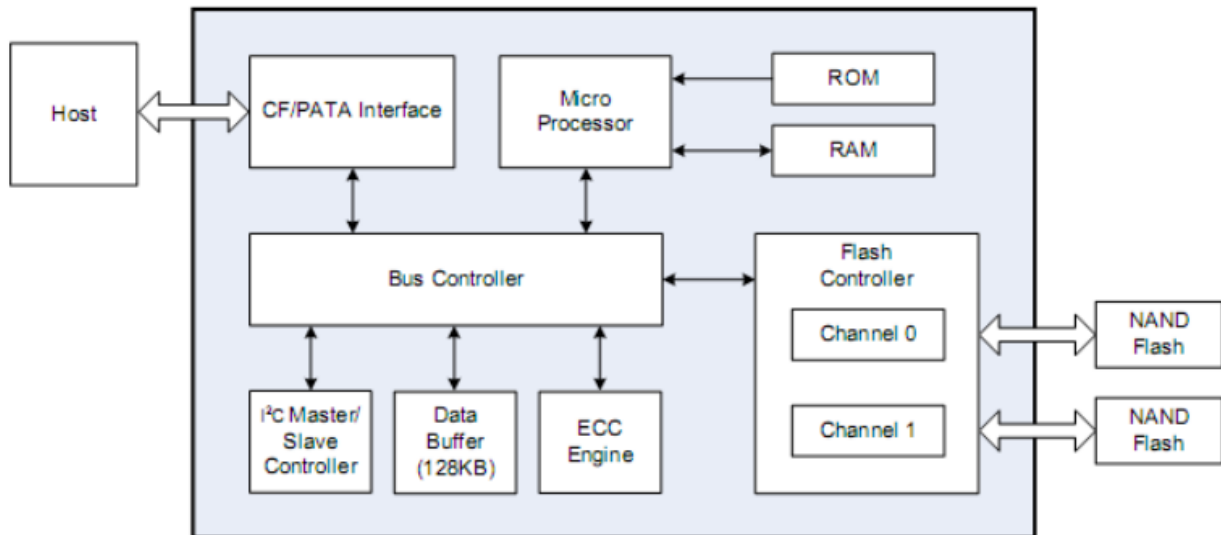

Figure 2-1: Functional block diagram

3. Pin Assignments

Table 3-1 lists the pin assignments with respective signal names for the 40-pin configuration. A “#” suffix indicates the active low signal. The pin type can be input, output or input/output.

Table 3-1: Pin assignments for the 40-pin configuration

Pin No	Signal Name	Tip Type	IO Type	Pin No	Signal Name	Tip Type	IO Type
1	RESET#	I	I2U	2	GND	-	Ground
3	D7	I/O	I1Z, O2	4	D8	I/O	I1Z, O2
5	D6	I/O	I1Z, O2	6	D9	I/O	I1Z, O2
7	D5	I/O	I1Z, O2	8	D10	I/O	I1Z, O2
9	D4	I/O	I1Z, O2	10	D11	I/O	I1Z, O2
11	D3	I/O	I1Z, O2	12	D12	I/O	I1Z, O2
13	D2	I/O	I1Z, O2	14	D13	I/O	I1Z, O2
15	D1	I/O	I1Z, O2	16	D14	I/O	I1Z, O2
17	D0	I/O	I1Z, O2	18	D15	I/O	I1Z, O2
19	GND	-	Ground	20	NC		Power
21	DMARQ	O	O1	22	GND		Ground
23	IOWR# STOP	I	I2Z	24	GND		Ground
25	IORD# HDMARDY# HSTROBE	I	I2Z	26	GND		Ground
27	IORDY DDMARDY# DSTROBE	O	O1	28	CSEL	I	I1U
29	DMACK#	I	I2U-	30	NC/WP# ¹	-/I	-/I1U
31	INTRQ#	O	O1	32	IOCS16#	O	O2
33	A1	I	I1Z	34	PDIAG#	I/O	I1U, O1
35	A0	I	I1Z	36	A2	I	I1Z
37	CS1FX#	I	I2Z	38	CS3FX#	I	I2Z
39	DASP#	I/O	I1U, O6	40	GND		Ground

1. Pin 30 is selectable as NC or WP# through a zero ohm resistor jumper. Default is NC. Note that pin 30 is a GND pin on standard ATA interface. This pin could be redesigned for host to control the write protect function on ADM

4. Capacity Specification

Standard capacity specification of the ATA Disk Module product is shown in Table 4-1. The table lists the specific capacity and the default numbers of heads, sectors and cylinders (CHS) for each product line.

Table 4-1: Capacity specifications

Capacity	Total Bytes ^{1,2}	Cylinders	Heads	Sectors	Max LBA
128MB	128,057,344	977	8	32	250,112
256MB	256,901,120	980	16	32	501,760
512MB	512,483,368	993	16	63	1,000,944
1GB	1,011,032,064	1,959	16	63	1,974,672
2GB	2,011,226,112	3,897	16	63	3,928,176
4GB	4,011,614,208	7,773	16	63	7,835,184
8GB	8,012,390,400	15,525	16	63	15,649,200
16GB	16,013,942,784	16383 ³	16	63	31,277,232
32GB	32,017,047,552	16383 ³	16	63	62,533,296

1. Total bytes includes reserved system blocks.
2. Total bytes displayed varies depending on the operating system.
3. Cylinders, heads or sectors are not applicable for these capacities. Only LBA addressing applies.

Please contact factory for any non-listed ATA Disk Module capacity or custom CHS requirement.

4.1 Performance Specification

Performance of ATA-Disk Module is listed in Table 4-2.

Table 4-2: Standard Performance specifications

Performance \ Capacity	128MB	256MB	512MB	1GB	2GB	4GB	8GB	16GB	32GB
	Sustained read (MB/s)	20	20	30	30	55	35	70	75
Sustained write (MB/s)	11	11	20	20	40	30	60	65	65

4.2 Environmental Specifications

Environmental specification of the ATA-Disk Module series follows the MIL-STD-810F standard as shown in Table 4-4.

Table 4-4: Environmental specifications

Environment		Specification
Temperature	Operation	0°C to 70°C (standard); -40°C to 85°C (Industrial temperature)
	Storage	-40°C to 100°C
Vibration		Sine wave: 10~2000Hz, 15G (X, Y, Z axes)
Shock		Half sine wave, Peak acceleration 50 G, 11 ms (X, Y, Z ; All 6 axes)
Humidity		5% to 95% RH (Non-condensing)

5. Flash Management

The most critical attribute of an Industrial grade ATA-Disk Module is its inherent high level of reliability. This characteristic is achieved through unique technical features of Flash Controller and specific component selection that offer higher degree of reliability compared to the consumer grade components.

5.1 Intelligent Flash Controller Features

5.1.1 Advanced wear-leveling algorithms

All NAND flash devices are limited by a finite number of write cycles. Under a standard file system, frequent file table updates are mandatory. As a painful side effect of OS file overhead, some areas of flash address space wear out faster than others. As these certain sections get a substantially higher write occurrence the whole ATA-Disk Module can wear out very quickly. This uneven wear would significantly reduce the lifetime of the whole device, even if majority of the Flash sectors are far from the write cycle limit. Fortasa's ATA-Disk Module products offer advanced data wear leveling which distributes Flash writes evenly across the ATA-Disk Module memory space. By utilizing this advanced wear leveling feature, the lifetime of the media can be significantly extended.

5.1.2 S.M.A.R.T. technology

S.M.A.R.T. is an acronym for Self-Monitoring, Analysis and Reporting Technology, an open standard allowing disk drives to automatically monitor their own health and report potential problems. It protects the user from unscheduled downtime by monitoring and storing critical drive performance and calibration parameters. Ideally, this should allow taking proactive actions to prevent impending drive failure. Fortasa SMART feature adopts the conventional SMART command B0h to read data from the drive. By having the Fortasa SMART Utility running on the host, the system can monitor and analyze the ATA-Disk Module status and determine the end of useful life for a graceful and scheduled maintenance and replacement.

5.1.3 Built-in hardware ECC

The Fortasa Flash Controller uses superior BCH Error Detection Code (EDC) and Error Correction Code (ECC) algorithms which correct up to 72 random single-bit errors for each 1kbyte block of data. High performance is fulfilled through hardware-based error detection and correction.

5.1.4 Enhanced data integrity

The properties of NAND flash memory make it ideal for applications that require high integrity while operating in challenging environments. The integrity of data to NAND flash memory is generally maintained through ECC algorithms and bad block management. Flash controllers can support up to 8 bits ECC capability for accuracy of data transactions, and bad block management is a preventive mechanism from loss of data by retiring unusable media blocks and relocating the data to the other blocks, along with the integration of advanced wear leveling algorithms, so that the lifespan of device can be expanded.

5.2 Intelligent Power Failure Recovery

The Low Power Detection on the Flash controller initiates cached data saving before the power supply to the device drops too low for operation. This feature prevents the device from system crash and ensures data integrity during an unexpected brownout. This feature makes sure that there are no catastrophic failures of the ATA-Disk Module due to system power glitches.

Please contact Fortasa Memory Systems Sales for more information about these unique features.

6. Software Interface

6.1 Command Set

Table 6-1 summarizes the command set with the paragraphs that follow describing the individual commands and the task file for each.

Table 6-1: Command set

Command	Code	FR ¹	SC ²	SN ³	CY ⁴	DH ⁵	LBA ⁶
Check-Power-Mode	E5H or 98H	-	-	-	-	D8	-
Execute-Drive-Diagnostic	90H	-	-	-	-	D	-
Erase-Sector(s)	C0H	-	Y	Y	Y	Y	Y
Flush-Cache	E7H	-	-	-	-	D	-
Format-Track	50H	-	Y ⁷	-	Y	Y ⁸	Y
Identify-Drive	ECH	-	-	-	-	D	-
Idle	E3H or 97H	-	Y	-	-	D	-
Idle-Immediate	E1H or 95H	-	-	-	-	D	-
Initialize-Drive-Parameters	91H	-	Y	-	-	Y	-
NOP	00H	-	-	-	-	D	-
Read-Buffer	E4H	-	-	-	-	D	-
Read DMA	C8H or C9H	-	Y	Y	Y	Y	Y
Read-Long-Sector	22H or 23H	-	-	Y	Y	Y	Y
Read-Multiple	C4H	-	Y	Y	Y	Y	Y
Read-Sector(s)	20H or 21H	-	Y	Y	Y	Y	Y
Read-Verify-Sector(s)	40H or 41H	-	Y	Y	Y	Y	Y
Recalibrate	1XH	-	-	-	-	D	-
Request-Sense	03H	-	-	-	-	D	-
Security-Disable-Password	F6H	-	-	-	-	D	-
Security-Erase-Prepare	F3H	-	-	-	-	D	-
Security-Erase-Unit	F4H	-	-	-	-	D	-
Security-Freeze-Lock	F5H	-	-	-	-	D	-
Security-Set-Password	F1H	-	-	-	-	D	-
Security-Unlock	F2H	-	-	-	-	D	-
Seek	7XH	-	-	Y	Y	Y	Y
Set-Features	EFH	Y	-	-	-	D	-
SMART	B0H	Y	Y	Y	Y	D	-
Set-Multiple-Mode	C6H	-	Y	-	-	D	-
Set-Sleep-Mode	E6H or 99H	-	-	-	-	D	-
Stand-By	E2H or 96H	-	-	-	-	D	-
Stand-By-Immediate	E0H or 94H	-	-	-	-	D	-
Translate Sector	87H	-	Y	Y	Y	Y	Y
Write-Buffer	E8H	-	-	-	-	D	-
Write DMA	CAH or CBH	-	Y	Y	Y	Y	Y
Write-Multiple	C5H	-	Y	Y	Y	Y	Y
Write-Multiple-Without-Erase	CDH	-	Y	Y	Y	Y	Y
Write-Sector(s)	30H or 31H	-	Y	Y	Y	Y	Y
Write-Sector(s)-Without-Erase	38H	-	Y	Y	Y	Y	Y
Write-Verify	3CH	-	Y	Y	Y	Y	Y

7. Electrical Specification

Caution: Absolute Maximum Stress Ratings – Applied conditions greater than those listed under “Absolute Maximum Stress Ratings” may cause permanent damage to the device. This is a stress rating only and functional operation of the device at these conditions or conditions greater than those defined in the operational sections of this data sheet is not implied. Exposure to absolute maximum stress rating conditions may affect device reliability.

Table 7-1: Operating range

Range	Ambient Temperature	3.3V	5V
Commercial	0°C to +70°C	3.135-3.465V	4.75-5.25V
Industrial	-40°C to +85°C		

Table 7-2: ATA Disk Module power consumption (typical)

Performance \ Capacity	128MB	256MB	512MB	1GB	2GB	4GB	8GB	16GB	32GB
	Active Mode (mW)	125	125	135	135	195	160	230	250
Idle Mode (mW)	15	15	15	15	15	15	15	15	15

8. Physical Characteristics

8.1 Dimensions

FIGURE 8-1: Physical dimension

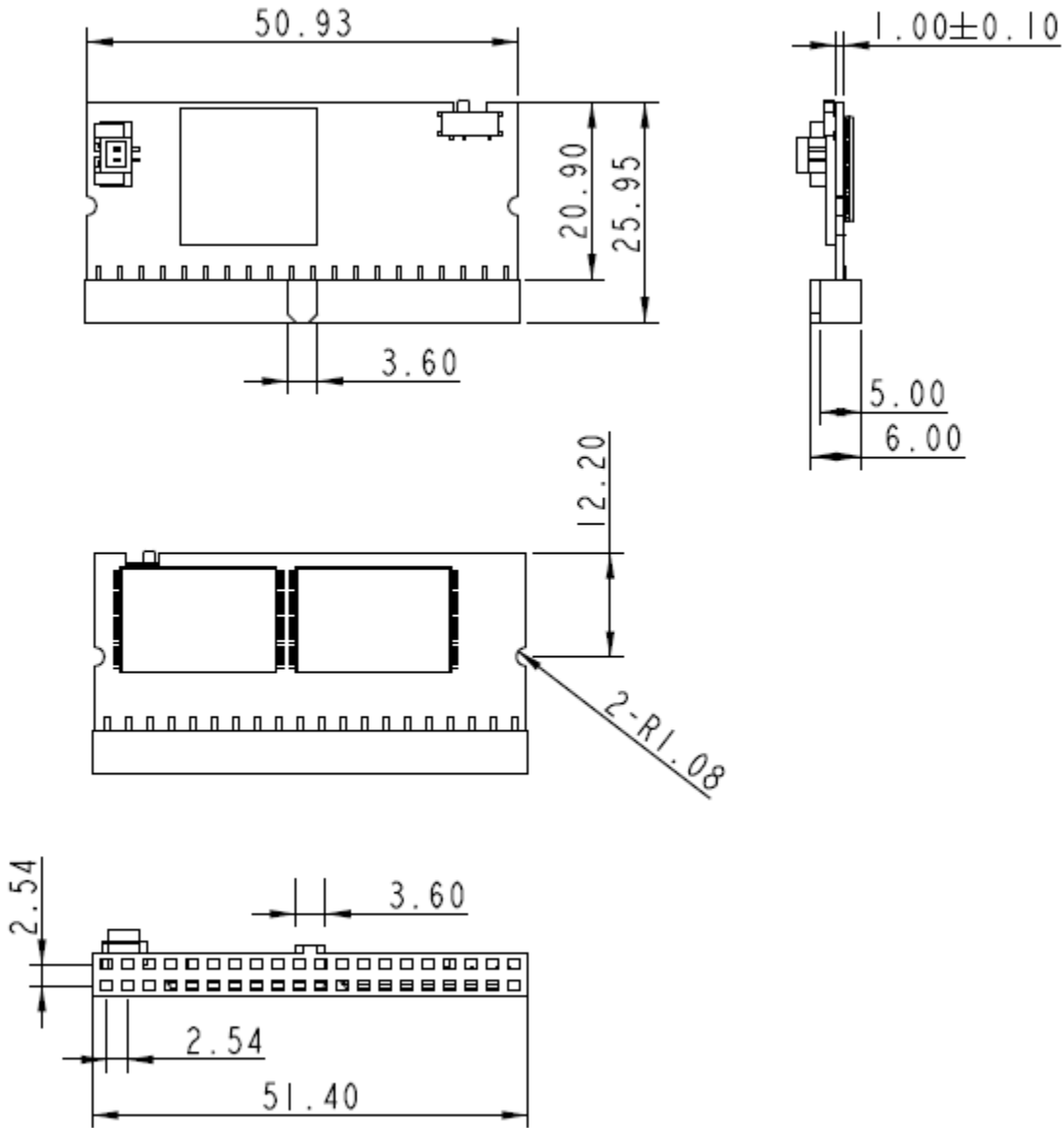

9. Product Ordering Information

9.1 Product Code Designations

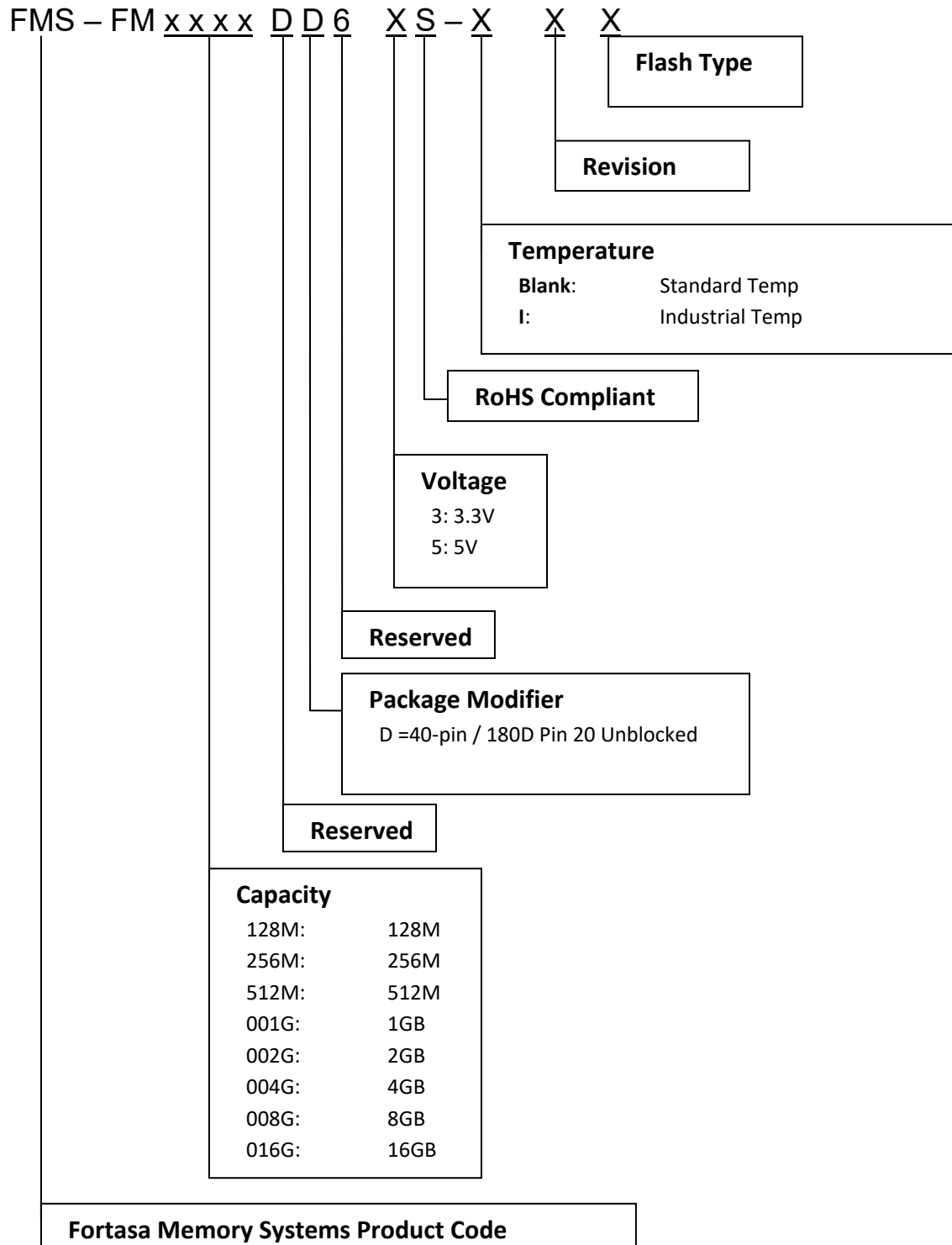

9.2 Valid Combinations

9.2.1 Standard Temperature

3.3V		5V	
Capacity	Model Number	Capacity	Model Number
128MB	FMS-FM128MDD63S-TM	128MB	FMS-FM128MDD65S-TM
256MB	FMS-FM256MDD63S-TM	256MB	FMS-FM256MDD65S-TM
512MB	FMS-FM512MDD63S-TM	512MB	FMS-FM512MDD65S-TM
1GB	FMS-FM001GDD63S-TM	1GB	FMS-FM001GDD65S-TM
2GB	FMS-FM002GDD63S-TM	2GB	FMS-FM002GDD65S-TM
4GB	FMS-FM016GDD63S-TM	4GB	FMS-FM004GDD65S-TM
8GB	FMS-FM004GDD63S-TM	8GB	FMS-FM008GDD65S-TM
16GB	FMS-FM008GDD63S-TM	16GB	FMS-FM016GDD65S-TM
32GB	FMS-FM032GDD63S-TM	32GB	FMS-FM032GDD65S-TM

9.2.2 Industrial Temperature

3.3V		5V	
Capacity	Model Number	Capacity	Model Number
128MB	FMS-FM128MDD63S-ITM	128MB	FMS-FM128MDD65S-ITM
256MB	FMS-FM256MDD63S-ITM	256MB	FMS-FM256MDD65S-ITM
512MB	FMS-FM512MDD63S-ITM	512MB	FMS-FM512MDD65S-ITM
1GB	FMS-FM001GDD63S-ITM	1GB	FMS-FM001GDD65S-ITM
2GB	FMS-FM002GDD63S-ITM	2GB	FMS-FM002GDD65S-ITM
4GB	FMS-FM004GDD63S-ITM	4GB	FMS-FM004GDD65S-ITM
8GB	FMS-FM008GDD63S-ITM	8GB	FMS-FM008GDD65S-ITM
16GB	FMS-FM016GDD63S-ITM	16GB	FMS-FM016GDD65S-ITM
32GB	FMS-FM032GDD63S-ITM	32GB	FMS-FM032GDD65S-ITM

10. Revision History

Revision	Date	Description	Comments
1.0	6/26/2015	Initial Release	
1.1	2/15/2016	Change Current Specification	
1.2	10/18/2016	Change Part Numbers	