

***RoHS Compliant***  
**CFast Card Series**  
***Datasheet for Industrial CFast Card Series***

**April 14, 2017**

**Revision 1.2**

***This Specification Describes the Features and Capabilities of  
the Standard and Industrial Temperature  
CFast Cards***

***Please Contact Fortasa Memory Systems Sales for any  
Custom Features Required For Your Specific Application***



1111 Triton Dr  
Suite 100  
Foster City, CA 94404 USA  
888-367-8588  
[www.fortasa.com](http://www.fortasa.com)

### Features:

- **Standard Serial SATA 3.1 (Gen 3)**
  - SATA 3.1 command set compatible
  - Serial SATA 6.0 Gbps
  - ATA compatible command set
- **Low power consumption (typical)**
  - Supply voltage: 3.3V±5%
  - Active mode: 440 mA
  - Sleep mode: 75 mA
- **Performance**
  - Sustained read: Up to 265 MB/sec
  - Sustained write: Up to 180 MB/sec
  - Random read (4K): up to 47,000 IOPS
  - Random write (4K): up to 44,000 IOPS
- **Capacity**
  - 8, 16, 32, 64, 128GB
- **NAND flash type: MLC**
- **MTBF (hours): >1,000,000**
- **Temperature ranges**
  - Operation:
    - Standard: 0°C to 70°C (32° ~ 158°F)
    - Industrial: -40°C to 85°C (-40° ~ 185°F)
  - Storage: -40°C to 100°C (-40° ~ 212°F)
- **Intelligent endurance design**
  - Built-in hardware ECC, enabling up to 72 bit correction per 1024 bytes
  - Global wear-leveling scheme together with dynamical block allocation to significantly increase the lifetime of a flash device and optimize the disk performance
  - Flash bad-block management
    - *Power Failure Management*
    - *ATA Secure Erase*
    - *SMART Command*
    - *Trim Command*
- **Connector Type**
  - 7-pin signal connector
  - 17-pin power connector
- **Shock and Vibration**
  - Shock: 1500g (approx.)
  - Vibration: 15g (approx.)
- **RoHS compliant**
- **Write Protect Switch**

---

## Table of Contents

1 Product Description .....	4
1.1 General Description.....	4
1.2 Functional Block .....	4
1.3 Capacity Specification.....	5
1.4 Performance Specification .....	5
1.5 Pin Assignments.....	6
2. Software Interface .....	7
2.1 Command Set.....	7
3. Flash Management .....	8
3.1 Error Correction/Detection.....	8
3.2 Wear Leveling .....	8
3.3 Power Failure Management.....	8
3.4 ATA Secure Erase .....	8
3.5 S.M.A.R.T. Technology .....	8
3.6 TRIM Command Support.....	9
3.7 SATA Power Management .....	9
3.8 Write Protect Switch .....	10
4. Environmental Specifications .....	11
4.1 Environments .....	11
4.2 Mean Time Between Failures (MTBF) .....	11
4.3 Certification and Compliance.....	11
5. Electrical Specification .....	12
5.1 Operating Voltage .....	12
5.2 Power Consumption .....	12
6. Physical Characteristics .....	13
6.1 Dimensions.....	13
7. Product Ordering Information.....	14
7.1 Product Code Designations .....	14
7.2 Valid Combinations.....	15
8. Revision History .....	16

## 1 Product Description

### 1.1 General Description

CFast emerged as an evolution of the CompactFlash card standard, by adopting a SATA bus interface to delivers a much higher data transfer rate required in the current generation of industrial and enterprise applications. Offering a substantially higher data throughput rate, CFast proved to be a more advanced embedded solution for cache, storage acceleration, communication and networking applications is a small, compact package.

Fortasa's CFast solution is designed with a powerful Flash controller that easily breaks the performance limit for CompactFlash by delivering the transfer rate up to 256 MB/s. Leveraging from CompactFlash form factor and SATA interface, CFast can be integrated into host computing system without excessive BIOS configurations and driver installations.

In addition to its peak performance, Fortasa CFast is designed with high reliability and data integrity. The CFast card adopts static wear-leveling to average the use of all flash blocks to prolong the lifetime and improve block efficiency of flash media. A built-in powerful ECC engine operates at hardware level for error correction and detection. CFast is an ideal storage device for industrial, enterprise and communication applications. **Manufactured using Industrial Temperature rated MLC NAND-flash, this SSD can work in highly demanding environment and withstand wide range of operating temperature from -40°C to +85°C.**

### 1.2 Functional Block

Fortasa CFast includes a single-chip SATA Controller and the flash media. The controller integrates the flash management unit to support multi-channel, multi-bank flash arrays. Figure 1-1 shows the functional block diagram.

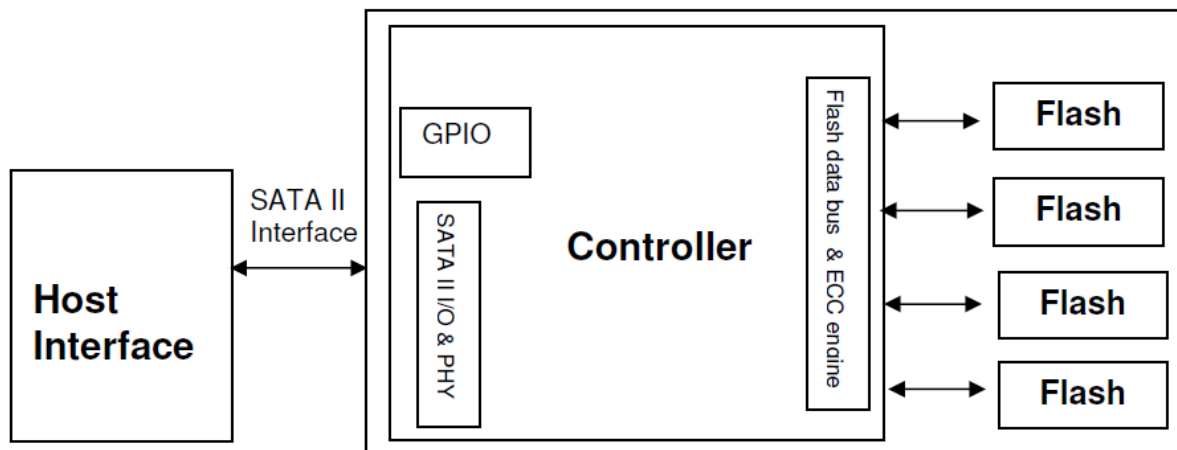

Figure 1-1: CFast functional block diagram

### 1.3 Capacity Specification

Standard capacity specification of the CFast product are shown in Table 1-1. The table lists the specific capacity and the default numbers of heads, sectors and cylinders (CHS) for each product line.

**Table 1-1: Capacity specifications**

Capacity	Total Bytes	Cylinders	Heads	Sectors	Max LBA
<b>8GB</b>	<b>8,012,390,400</b>	<b>15525</b>	<b>16</b>	<b>63</b>	<b>15,649,200</b>
<b>16GB</b>	<b>16,013,942,784</b>	<b>16383<sup>1</sup></b>	<b>16</b>	<b>63</b>	<b>31,277,232</b>
<b>32GB</b>	<b>32,017,047,552</b>	<b>16383<sup>1</sup></b>	<b>16</b>	<b>63</b>	<b>62,533,296</b>
<b>64GB</b>	<b>64,023,257,088</b>	<b>16383<sup>1</sup></b>	<b>16</b>	<b>63</b>	<b>125,045,424</b>
<b>128GB</b>	<b>128,035,676,160</b>	<b>16383<sup>1</sup></b>	<b>16</b>	<b>63</b>	<b>250,069,680</b>

1. Cylinders, heads or sectors are not applicable for these capacities. Only LBA addressing applies. LBA count addressed in the table above indicates total user storage capacity and will remain the same throughout the lifespan of the device. However, the total usable capacity of the CFast is most likely to be less than the total physical capacity because a small portion of the capacity is reserved for device maintenance usages.
2. Display of total bytes varies from file systems.

*Please contact factory for any non-listed CFast capacity or custom CHS requirement.*

### 1.4 Performance Specification

Performances of the CFast device are listed in Table 1-2.

**Table 1-2: Standard Performance specifications**

Capacity \ Performance	8GB	16GB	32GB	64GB	128GB
<b>Sustained read (MB/s)</b>	120	220	220	280	265
<b>Sustained write (MB/s)</b>	26	50	45	90	180
<b>Random Read IOPS (4K)</b>	15,000	26,000	25,000	46,000	47,000
<b>Random Write IOPS (4K)</b>	4,000	10,000	11,000	22,000	44,000

## 1.5 Pin Assignments

Figure 1-2: Pin Assignment

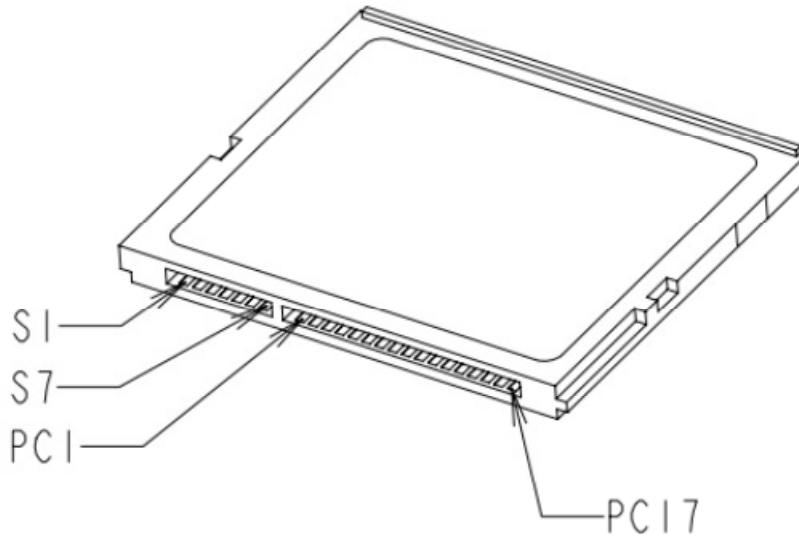
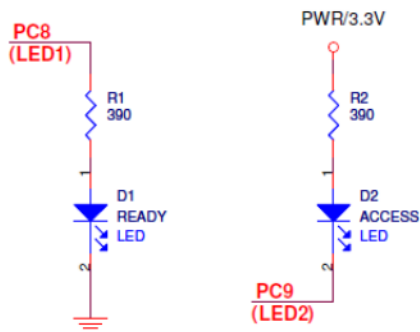

Table 1-3: Signal Segment

Pin	Signal	Description
S1		Ground
S2	A+	SATA Differential Signal Pair A
S3	A-	
S4		Ground
S5	B-	SATA Differential Signal Pair B
S6	B+	
S7		Ground

Table 1-4: Power Segment

Pin	Name	Type	Description
PC1	CDI	CMOS Input	Card Detect In
PC2	GND	Device GND	
PC3	TBD	TBD	
PC4	TBD	TBD	
PC5	TBD	TBD	
PC6	TBD	TBD	
PC7	GND	Device GND	
PC8*	LED1	LED Output	Ready
PC9*	LED2	LED Output	Access
PC10			Reserved I/O
PC11			Write Protect**
PC12			Reserved I/O
PC13	PWR	3.3V	Device Power 3.3V
PC14	PWR	3.3V	Device Power 3.3V
PC15	PGND	Device GND	Device GND
PC16	PGND	Device GND	Device GND
PC17	PGND	CMOS Output	Card Detect Out



\*Refer above for LED output design guide

\*\*Enabled by adjusting the pin "PC11" from high to low active

## 2. Software Interface

### 2.1 Command Set

Table 2-1 summarizes the command set with the paragraphs that follow describing the individual commands and the task file for each.

**Table 2-1:** Command set

<b>Command</b>	<b>Code</b>	<b>Command</b>	<b>Code</b>
Check-Power-Mode	E5H	Security-Erase-Prepare	F3H
Data Set Management	06H	Security-Erase-Unit	F4H
Execute-Drive-Diagnostic	90H	Security-Freeze-Lock	F5H
Flush-Cache	E7H	Security-Set-Password	F1H
Flush-Cache EXT	EAH	Security-Unlock	F2H
Identify-Drive	ECH	Seek	70H
Idle	E3H	Set-Features	EFH
Idle-Immediate	E1H	SMART	B0H
Initialize-Drive-Parameters	91H	Set-Multiple-Mode	C6H
Read DMA	C8H	Set-Sleep-Mode	E6H
Read DMA EXT	25H	Stand-By	E2H
Read-Multiple	C4H	Stand-By-Immediate	E0H
Read-Multiple EXT	29H	Write DMA	CAH
Read-Sector	20H	Write DMA EXT	35H
Read-Sector EXT	24H	Write-Multiple	C5H
Read-Verify-Sectors	40H	Write-Multiple EXT	39H
Read-Verify-Sectors EXT	42H	Write-Sector	30H
Recalibrate	1XH	Write-Sector EXT	34H
Security-Disable-Password	F6H		

---

### 3. Flash Management

#### 3.1 Error Correction/Detection

The CFast implements a hardware BCH-based ECC scheme to achieve up to 72 bit correction per 1024-byte page.

#### 3.2 Wear Leveling

All NAND flash devices are limited by a finite number of write cycles. Under a standard file system, frequent file table updates are mandatory. As a painful side effect of OS file overhead, some areas of flash address space wear out faster than others. As these certain sections get a substantially higher write occurrence the whole CFast can wear out very quickly. This uneven wear would significantly reduce the lifetime of the whole device, even if majority of the Flash sectors are far from the write cycle limit. Fortasa's CFast products offer advanced data wear leveling which distributes Flash writes evenly across the full memory space. By utilizing this advanced wear leveling feature, the lifetime of the media can be significantly extended.

#### 3.3 Power Failure Management

The Low Power Detection on the Flash controller initiates cached data saving before the power supply to the device drops too low for operation. This feature prevents the device from system crash and ensures data integrity during an unexpected brownout. This feature makes sure that there are no catastrophic failures of the CFast due to system power glitches.

#### 3.4 ATA Secure Erase

Accomplished by the Secure Erase (SE) command, which added to the open ANSI standards that control disk drives, "ATA Secure Erase" is built into the disk drive itself and thus far less susceptible to malicious software attacks than external software utilities. It is a positive easy-to-use data destroy command, amounting to electronic data shredding. Executing the command causes a drive to internally completely erase all possible user data. This command is carried out within disk drives, so no additional software is required. The erase process will not stop until it is completed. In case of power failure, the erase process will continue when the power is reapplied to the device.

#### 3.5 S.M.A.R.T. Technology

S.M.A.R.T. is an acronym for Self-Monitoring, Analysis and Reporting Technology, an open standard allowing disk drives to automatically monitor their own health and report potential problems. It protects the user from unscheduled downtime by monitoring and storing critical drive performance and calibration parameters. Ideally, this should allow taking proactive actions to prevent impending drive failure.

Code	SMART Subcommand
D0h	READ DATA
D1h	READ ATTRIBUTE THRESHOLDS
D2h	Enable/Disable Attribute Autosave
D4h	Execute Off-line Immediate
D5h	Read Log (optional)
D6h	Write Log (optional)
D8h	Enable Operations
D9h	Disable operations
DAh	Return Status



**General SMART attribute structure**

Byte	Description
0	ID (Hex)
1 – 2	Status flag
3	Value
4	Worst
5*-11	Raw Data

\*Byte 5: LSB

**SMART attribute ID list**

ID (Hex)	Attribute Name
9 (0x09)	Power-on hours
12 (0x0C)	Power cycle count
163 (0xA3)	Max. erase count
164 (0xA4)	Avg. erase count
166 (0xA6)	Total later bad block count
167 (0xA7)	SSD Protect Mode (vendor specific)
168 (0xA8)	SATA PHY Error Count
175 (0xAF)	Bad Cluster Table Count
192 (0xC0)	Unexpected Power Loss Count
194 (0xC2)	Temperature
241 (0xF1)	Total sectors of write

**3.6 TRIM Command Support**

Over time the performance of SSD degrades as user continually writes and erases data. The ATA-TRIM command “formats” the SSD to optimize the drive performance. A TRIM enabled SSD running an OS with TRIM support will stay closer to its peak performance without much performance variance.

**3.7 SATA Power Management**

The CFast card supports the following SATA power saving modes:

- ACTIVE: PHY ready, full power, Tx & Rx operational
- PARTIAL: Reduces power, resumes in under 10 μs (microseconds)
- SLUMBER: Reduces power, resumes in under 10 ms (milliseconds)
- HIPM: Host-Initiated Power Management
- DIPM: Device-Initiated Power Management
- AUTO-SLUMBER: Automatic transition from partial to slumber.

Note:

1. The behaviors of power management features depend on host/device settings.

### 3.8 Write Protect Switch

Fortasa CFast card includes a Data Write Protect Switch. See Physical Characteristics section for Write Protect Switch location.

Once the Write Protect mode is enabled, the card will exhibit a Virtual Write scheme that will allow all destructive (write or erase) commands to be accepted by the flash controller and new data temporarily stored, but no data will actually be written into the flash. Once the system is reset and rebooted, the temporarily stored data will be destroyed and nowhere to be found in the system. Since the Virtual Write scheme runs at device level, it requires no software or driver installation and is independent from the host OS. Also all destructive commands will not generate a write error and will be transparent to device operation.

## 4. Environmental Specifications

### 4.1 Environments

Environmental specification of the CFast series follows the MIL-STD-810F standard as shown in Table 4-1.

**Table 4-1:** Environmental specifications

Environment		Specification
Temperature	Operation	0°C to 70°C (Standard); -40°C to 85°C (Industrial)
	Storage	-40°C to 100°C
Vibration		Non-operating : Sine wave, 15(G), 10~2000(Hz), Operating : Random, 7.69(Grms), 20~2000(Hz)
Shock-Operating		Acceleration: 1,500 G, 0.5 ms Peak acceleration: 50 G, 11 ms
Humidity		5% to 95% RH (Non-condensing)

### 4.2 Mean Time Between Failures (MTBF)

Mean Time Between Failures (MTBF) is predicted based on reliability data for the individual components in the SAFD drive. Based on provided component data, CFast is rated at more than 1,000,000 hours.

Notes about the MTBF:

The prediction is based on Bellcore analysis method by assuming device failure rate can be generated by the sum of failure rates in each component.

### 4.3 Certification and Compliance

The CFast card complies with the following standards:

- CE
- FCC
- RoHS
- MIL-STD-810F

## 5. Electrical Specification

### 5.1 Operating Voltage

**Caution: Absolute Maximum Stress Ratings** – Applied conditions greater than those listed under “Absolute Maximum Stress Ratings” may cause permanent damage to the device. This is a stress rating only and functional operation of the device at these conditions or conditions greater than those defined in the operational sections of this data sheet is not implied. Exposure to absolute maximum stress rating conditions may affect device reliability.

**Table 5-1:** Operating range

Range	Ambient Temperature	Conditions
Standard	0°C to +70°C	3.135 V – 3.465 V
Industrial	-40°C to 85°C	

### 5.2 Power Consumption

Table 5-2 lists the CFast power consumption.

**Table 5-2** CFast power consumption (typical)

Performance \ Capacity	8GB	16GB	32GB	64GB	64GB
	<b>Active Mode (mA)</b>	195	225	230	295
<b>Stand-by Mode (mA)</b>	75	75	75	75	75

## 6. Physical Characteristics

### 6.1 Dimensions

Figure 6-1 illustrates the overall dimensions of the CFast card.

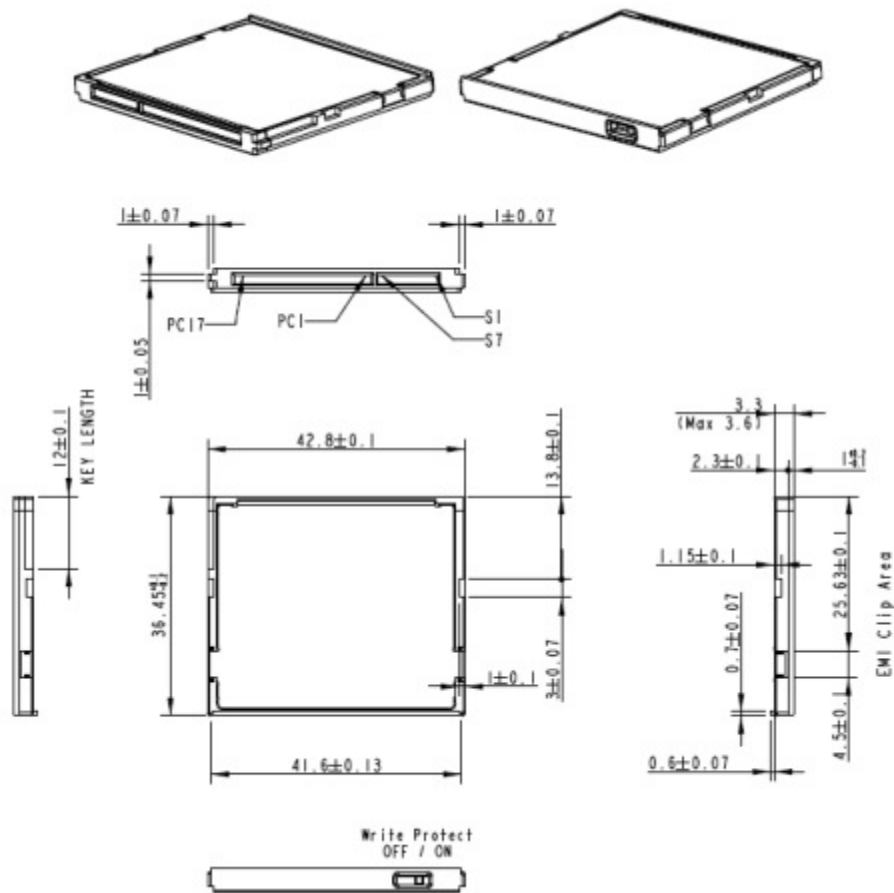

Unit: mm

## 7. Product Ordering Information

### 7.1 Product Code Designations

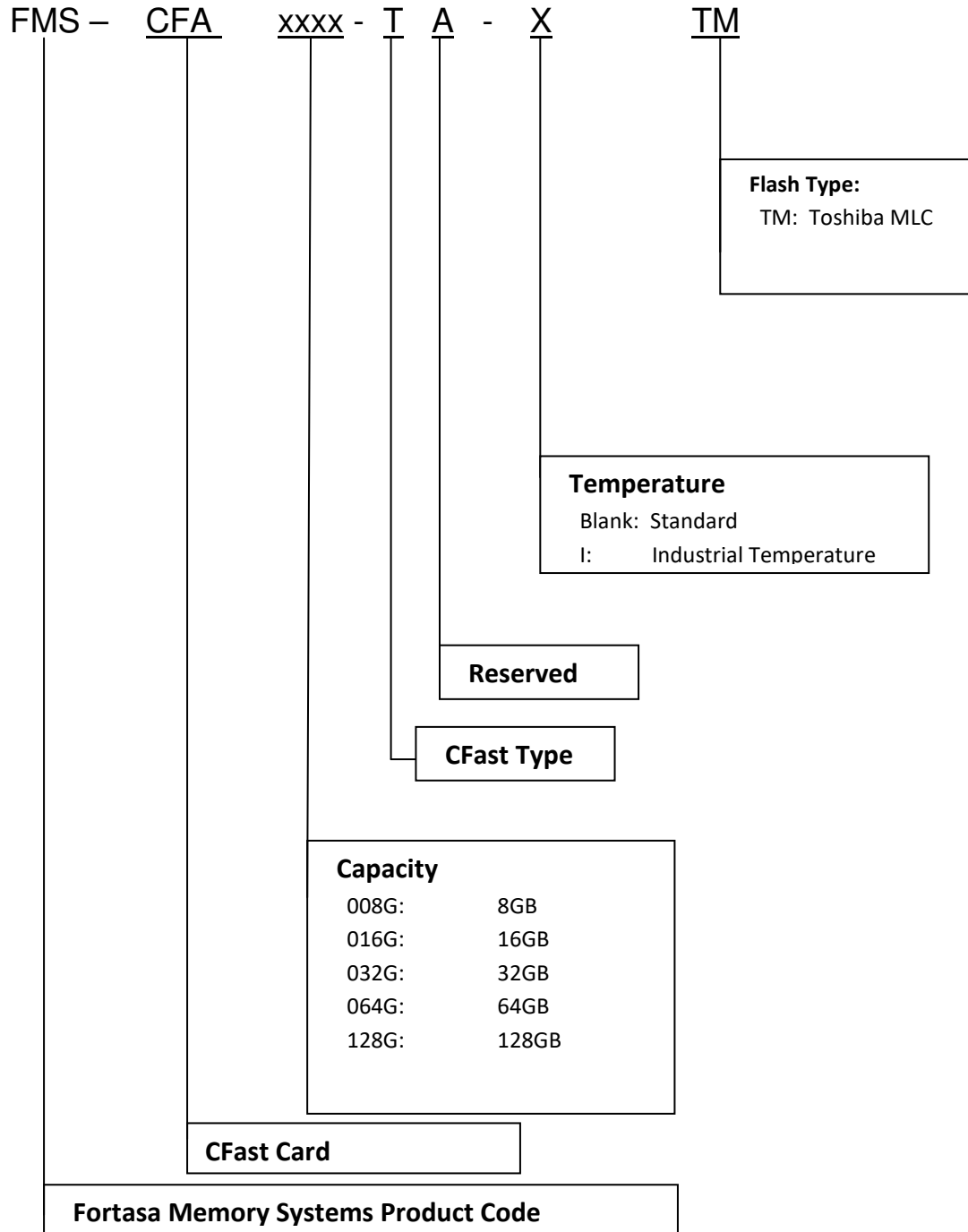

---

## 7.2 Valid Combinations

Capacity	Standard Temperature Model Numbers	Industrial Temperature Model Numbers
8GB	FMS-CFA008GTA-TM	FMS-CFA008GTA-ITM
16GB	FMS-CFA016GTA-TM	FMS-CFA016GTA-ITM
32GB	FMS-CFA032GTA-TM	FMS-CFA032GTA-ITM
64GB	FMS-CFA064GTA-TM	FMS-CFA064GTA-ITM
128GB	FMS-CFA128GTA-TM	FMS-CFA128GTA-ITM

**Note:** Valid combinations are those products in mass production or will be in mass production. Consult your Fortasa sales representative to confirm availability of valid combinations and to determine availability of new product combinations

---

## 8. Revision History

Revision	Date	Description	Comments
1.0	2/7/2017	Initial Release	
1.1	3/29/2017	Added 128GB Capacity	
1.2	4/14/2017	Updated Product Ordering Information	

Copyright © 2017 Fortasa Memory Systems, Inc. All Rights Reserved.

Information in this document is subject to change without prior notice.

Fortasa name and the Fortasa logo are trademarks or registered trademarks of  
Fortasa Memory Systems, Inc.

Other brands, names, trademarks or registered trademarks may be claimed as the property of  
their respective owners.