

RoHS Compliant

Industrial S1 SD Card Series

Datasheet for Industrial SD Card

April 19, 2018

Revision 1.1

This Specification Describes the Features and Capabilities of the Standard and Industrial Temperature Industrial SD Cards

Please Contact Fortasa Memory Systems Sales for any Custom Features Required For Your Specific Application



1670 So. Amphlett Blvd.
Suite 214-33
San Mateo, CA 94402 USA
888-367-8588
www.fortasa.com

Features:

- **Fully compatible with SD Card standard**
 - SD Memory Card Specifications, Part 1, Physical Layer Specification, Version 2.00
 - SD Memory Card Specifications, Part 2, File System Specification, Version 2.00
 - SD Memory Card Specifications, Part 3, Security Specification, Version 2.00
- **Low power consumption (typical)**
 - Supply voltage: 3.3V±5%
 - Read mode: 45 mA
 - Write mode: 55 mA
 - Standby mode: 110 µA
- **Performance**
 - Sustained Read: up to 23 MB/sec
 - Sustained write: up to 17 MB/sec
- **Capacity**
 - Standard: 256, 512MB, 1, 2 GB
 - SDHC: 4, 8, 16, 32GB
- **NAND flash type: SLC**
- **Temperature ranges**
 - Operation:
 - Standard Temperature: 0°C to 70°C
 - Industrial Temperature: -40°C to 85°C
 - Storage: -40°C to 100°C
- **Intelligent endurance design**
 - Built-in hardware ECC, enabling up to 24 bit correction per 1Kbyte page size
 - Global wear-leveling scheme together with dynamical block allocation to significantly increase the lifetime of a flash device and optimize the disk performance
 - Flash bad-block management
- **Physical Dimentions**
 - 24mm x 32mm x 2.1 mm
- **RoHS compliant**
- **MTBF:** >2,000,000 hours
- **Endurance in Terrabytes Written (TBW)**
 - 256 MB: 3.1 TBW
 - 512 MB: 6.1 TBW
 - 1 GB: 12.3 TBW
 - 2 GB: 24.5 TBW
 - 4 GB: 49.1 TBW
 - 8 GB: 98.1 TBW
 - 16 GB: 196.4 TBW
 - 32 GB: 392.7 TBW

Table of Contents

1 Product Description	4
1.1 General Description.....	4
1.2 Functional Block	4
1.3 Functional Description	5
1.3.1 Flash Management	5
1.3.2 Powerful ECC Algorithm.....	5
1.3.3 Power Management.....	5
1.4 Capacity Specification.....	5
1.5 Performance Specification	6
1.6 Card Architecture	6
1.7 Pin Assignments.....	6
2. Environmental Specifications	7
2.1 Environments	7
2.2 System Reliability	7
2.3 Endurance.....	8
3. Electrical Specification	8
3.1 Operating Voltage	8
3.2 Power Consumption	8
4. Physical Dimensions	9
5. Product Ordering Information.....	11
5.1 Product Code Designations	11
5.2 Valid Combinations.....	12
6. Revision History	13

1 Product Description

1.1 General Description

Fortasa's Industrial SD card is a high reliability solid state storage solution designed specifically to address the rigorous requirements of OEM customers. The SLC-NAND based Industrial SD cards offer the highest endurance, reliability and environmental agility.

1.2 Functional Block

The Industrial SD card includes a single-chip SD Interface Flash Controller and the flash media. The controller integrates the flash management unit to support multi-channel, multi-bank flash arrays. Figure 1-1 shows the functional block diagram of the Industrial SD card.

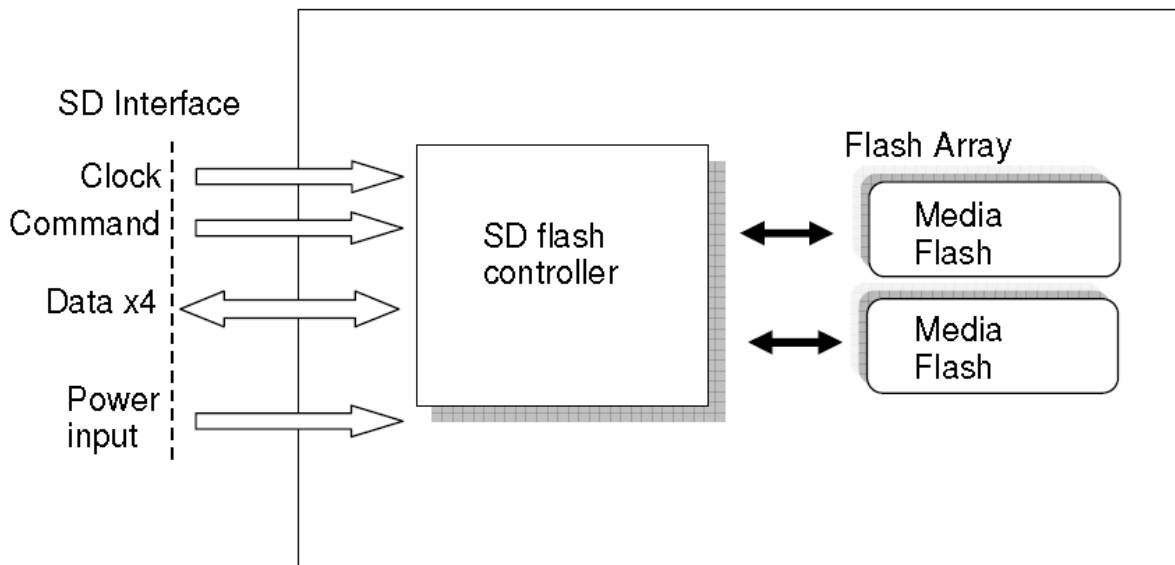

Figure 1-1: Functional block diagram

1.3 Functional Description

The Industrial SD card contains an integrated logical subsystem that provides multiple management capabilities including:

- Powerful Error Correction Algorithm
- Global Wear Leveling Algorithm
- Critical Power Management for low power operation

1.3.1 Flash Management

The Industrial SD Flash controller contains logic/physical flash block mapping and bad block management system. It manages all flash blocks including user data space, spare block space and system overhead blocks.

1.3.2 Powerful ECC Algorithm

The Industrial SD also contains a sophisticated defect and error management system. In case that a bit is found to be defective, the Flash Controller on-the-fly ECC engine mathematically recalculates the missing bit to provide the requested with outmost integrity. This operation is completely transparent to the host and does not consume any user data space. The built-in BCH-ECC supports correction of upto 24 bits of data per 1024 byte sector automatically.

1.3.3 Power Management

A power saving feature of the Industrial SD is an automatic entrance and exit from sleep mode. Upon completion of an operation, the SD will enter sleep mode to conserve power if no additional commands are received within a set number of seconds. The host does not have to take any action for this to occur. The SD card is always in the sleep mode except when the host is accessing it, thus conserving power.

Any command issued by the host to the Industrial SD will cause it to exit sleep mode and response to the host.

1.4 Capacity Specification

Standard capacity specification of the Industrial SD product is shown in Table 1-1.

Table 1-1: Capacity specifications

Capacity	Total (LBA) Sectors	Total Partition Sectors	User Data Sectors	User Data Bytes
256MB	499,712	499,611	499,456	255,721,472
512MB	985,088	984,851	984,576	513,540,912
1GB	2,000,896	2,000,651	2,000,128	1,024,065,536
2GB	4,009,984	4,009,739	4,009,216	2,052,718,592
4GB	8,019,968	8,011,776	8,003,584	4,097,835,008
8GB	16,039,936	16,031,744	16,023,552	8,204,025,856
16GB	31,719,424	31,711,232	31,703,040	16,231,923,712
32GB	63,438,848	63,430,656	63,414,272	32,468,074,496

Please contact factory for any non-listed SD capacity or custom setting requirement.

1.5 Performance Specification

Performances of the Industrial SD card are listed in Table 1-2.

Table 1-2: Standard Performance specifications

Performance	Capacity	256MB	512MB	1GB	2GB	4GB	8GB	16GB	32GB
	Sustained read (MB/s)		22	23	23	23	23	23	23
Sustained write (MB/s)		11	17	17	17	17	17	17	18

Note: Performances vary from flash configurations or host device settings

1.6 Card Architecture

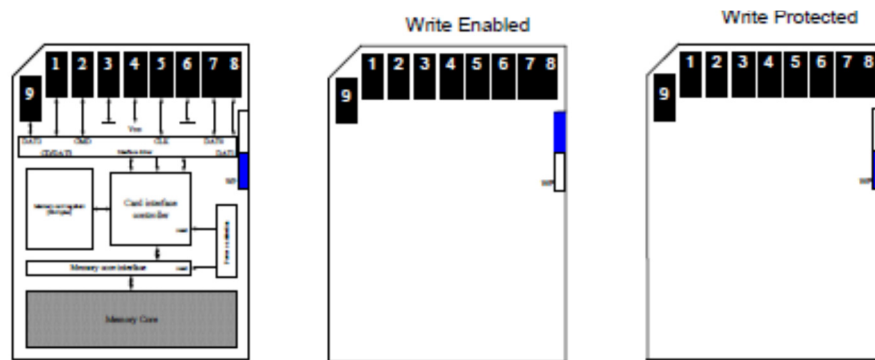

1.7 Pin Assignments

Pin	SD Mode		SPI Mode	
	Name	Description	Name	Description
1	CD/DAT3	Card Detect/Data line[Bit 3]	CS	Chip Select
2	CMD	Command/Response	DI	Data In
3	VSS1	Supply Voltage GND	VSS	Supply Voltage GND
4	VDD	Supply Voltage	VDD	Supply Voltage
5	CLK	Clock	SCLK	Clock
6	VSS2	Supply Voltage GND	VSS2	Supply Voltage GND
7	DAT0	Data Line [Bit 0]	DO	Data out
8	DAT1	Data Line [Bit 1]	Reserved	
9	DAT2	Data Line [Bit 2]	Reserved	

2. Environmental Specifications

2.1 Environments

Environmental specification of the Industrial SD series follows the MIL-STD-810F standard as shown in Table 2-1.

Table 2-1: Environmental specifications

Environment		Specification
Temperature	Operation	0°C to 70°C (standard); -40°C to 85°C (industrial)
	Storage	-40°C to 100°C
Humidity	Operation	25°C - 95% RH (Non-condensing)
	Storage	40°C - 93% RH (Non-condensing)
Salt Spray	Non -Operating	5%wt NaCl Solution Temperature:35°C 24hr
Bending	Non -Operating	10N
Torque	Non -Operating	0.15N.m or angle = ± 2.5 deg.(Max)
Drop	Non -Operating	1.5 m free fall
X-ray Exposure		0.1 Gy of medium-energy radiation (70 keV to 140keV, cumulative dose per year) to both sides of the card, according to ISO 7816-1.
Minimum Moving Force of WP switch		Moving Force: 40gf (Ensures that the WP switch will not slide while it is inserted inside a connector)
WP Switch Cycles		Minimum 1,000 Cycles (@ Slideforce: 0.4N-5N)

2.2 System Reliability

Durability	10,000 Mating Cycles
-------------------	----------------------

2.3 Endurance

The endurance of a storage device is predicted by a JEDEC approved test methodology. The data, reported in TeraBytes Written, is based on several factors related to device architecture and product usage, such as the amount of data written into the drive, block management conditions, and daily workload for the drive. Please contact Sales to learn more about the TBW analysis and calculations.

Capacity	TBW
256MB	3.1
512MB	6.1
1GB	12.3
2GB	24.5
4GB	49.1
8GB	98.2
16GB	196.4
32GB	392.7

Notes:

- The measurement assumes the data written to the SSD for test is under a typical and constant rate.
- The measurement follows the standard metric: 1 TB (Terabyte) = 1000 GB.

3. Electrical Specification

3.1 Operating Voltage

Caution: Absolute Maximum Stress Ratings – Applied conditions greater than those listed under “Absolute Maximum Stress Ratings” may cause permanent damage to the device. This is a stress rating only and functional operation of the device at these conditions or conditions greater than those defined in the operational sections of this data sheet is not implied. Exposure to absolute maximum stress rating conditions may affect device reliability.

Table 3-1: Operating range

Range	Ambient Temperature	Conditions
Standard	0°C to +70°C	3.3 V ±10% (2.7-3.3 V)
Industrial	-40°C to 85°C	

3.2 Power Consumption

Table 3-2 lists the Industrial SD power consumption.

Table 3-2 Industrial SD power consumption

Capacity	Measurement	Condition
Performance		
Read Mode (mA)	45	Typical
Write Mode (mA)	55	Typical
Standby Mode (µA)	110	Typical

4. Physical Dimensions

Table 4-1 Industrial SD Card dimensions

Dimension	Millimeters (mm)
Length and Width	24 mm x 32 mm Min. 23.9 mm x 31.9 mm Max. 24.1 mm x 32.1 mm
Thickness	2.1 mm ± 0.15 mm
Surface	Plain (except contact areas)
Edges	Smooth Edges

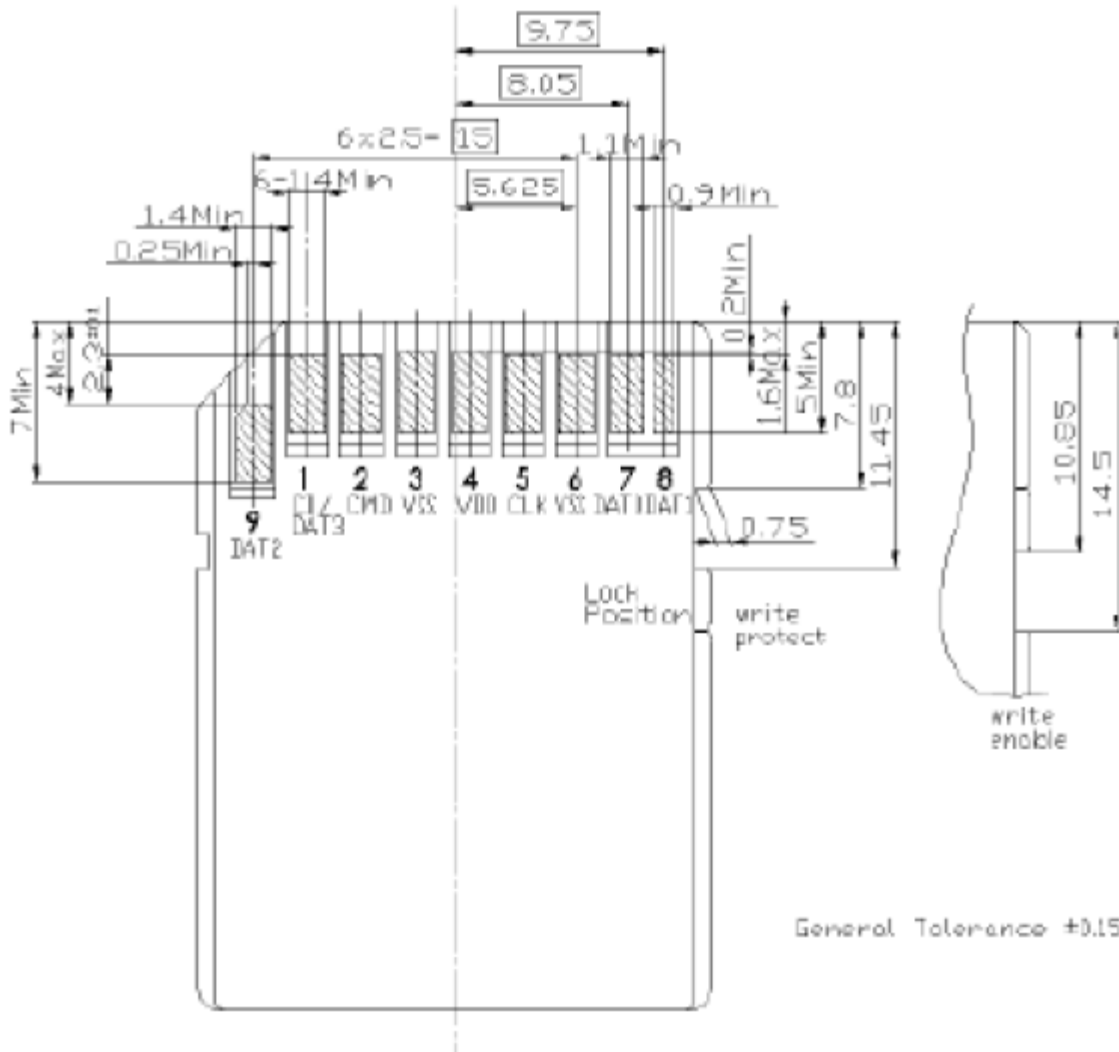

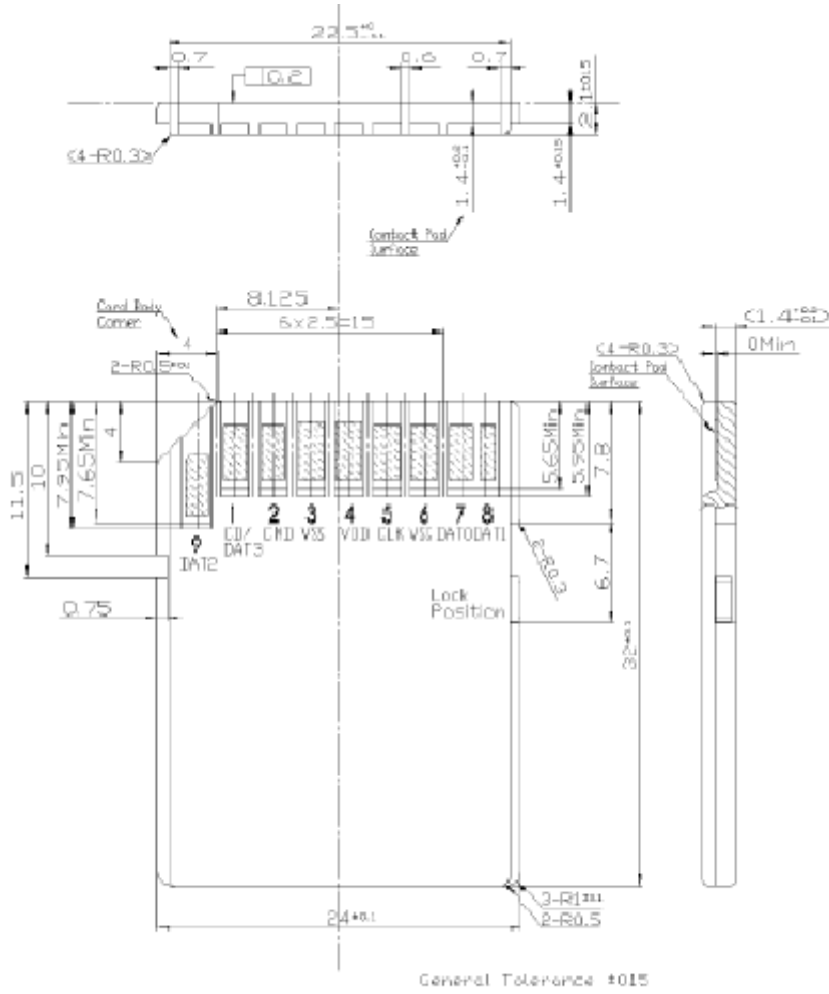

5. Product Ordering Information

5.1 Product Code Designations

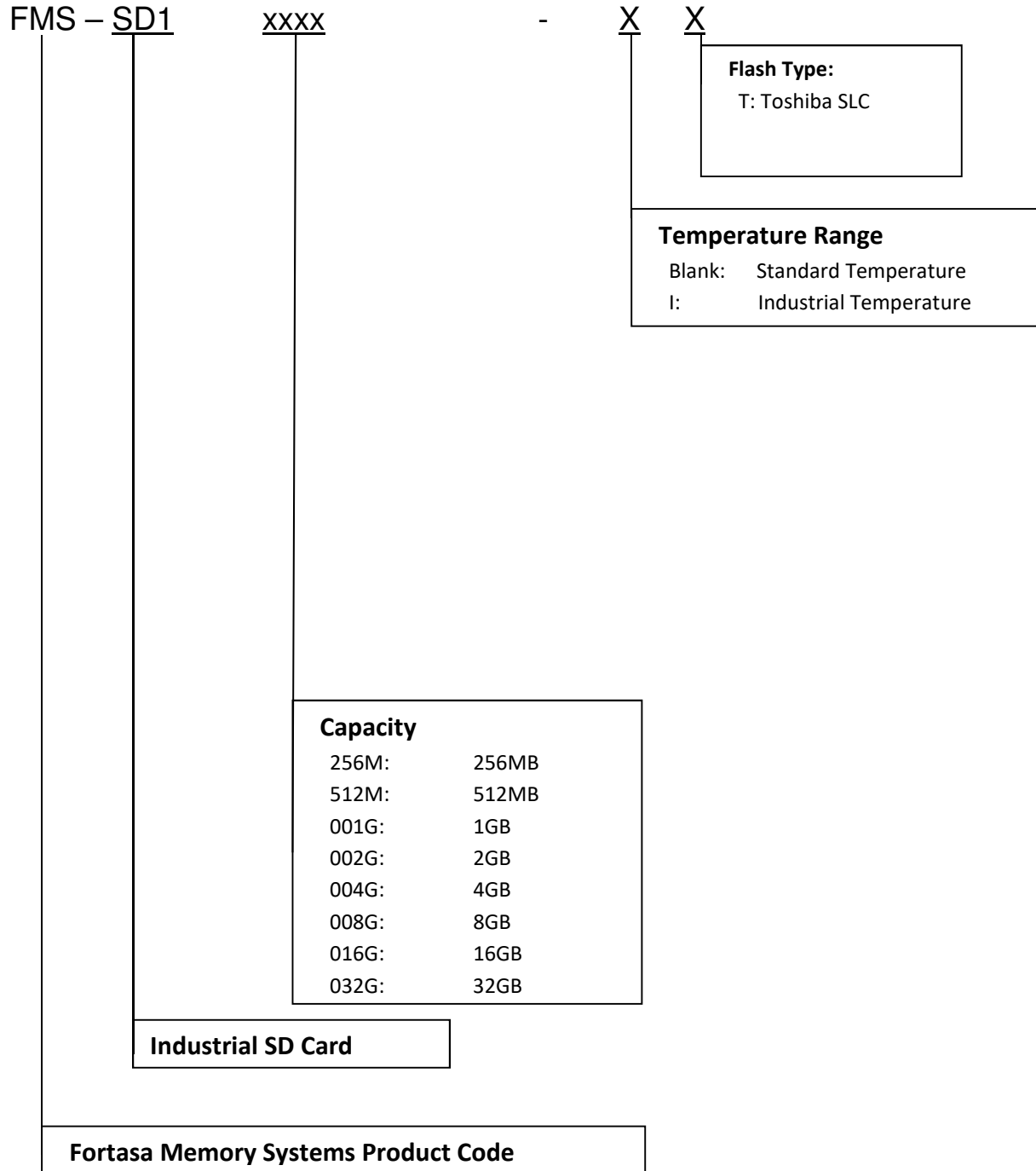

5.2 Valid Combinations

Capacity	Standard Temperature Model Numbers	Industrial Temperature Model Numbers
256MB	FMS-SD1256M-T	FMS-SD1256M-IT
512MB	FMS-SD1512M-T	FMS-SD1512M-IT
1GB	FMS-SD1001G-T	FMS-SD1001G-IT
2GB	FMS-SD1002G-T	FMS-SD1002G-IT
4GB	FMS-SD1004G-T	FMS-SD1004G-IT
8GB	FMS-SD1008G-T	FMS-SD1008G-IT
16GB	FMS-SD1016G-T	FMS-SD1016G-IT
32GB	FMS-SD1032G-T	FMS-SD1032G-IT

Note: Valid combinations are those products in mass production or will be in mass production. Consult your Fortasa sales representative to confirm availability of valid combinations and to determine availability of new product combinations

6. Revision History

Revision	Date	Description	Comments
1.0	2/25/2017	Initial Release	
1.1	4/19/2018	Added endurance rating for 32GB	