

RoHS Compliant
SATA Flash Drive Series
Datasheet for SF18A-KM

July 29, 2025

Revision 1.0

***This Specification Describes the Features and
Capabilities of the Standard and Industrial
Temperature
SATA Flash Drives***

***Please Contact Fortasa Memory Systems Sales for
any Custom Features Required For Your Specific
Application***



1670 So. Amphlett Blvd.
Suite 214-33
San Mateo, CA 94404 USA
888-367-8588
www.fortasa.com

SATA Flash Drive – 1.8”

FMS-SF18AxxxG-XKM



Features:

- **Standard Serial SATA 3.2**
 - Serial SATA 6.0 Gbps Interface
 - Backward compatible with SATA 1.5 and 3.0 Gbps interfaces
 - ATA-8 compatible command set
- **Low power consumption (typical)**
 - Supply voltage: 3.3V±5%
 - Active mode (max): 800 mA
 - Idle mode: 100 mA
 - Supply voltage: 5V±5%
 - Active mode (max): 510 mA
 - Idle mode: 70 mA
- **Capacity**
 - 32, 64, 128, 256, 512 GB
- **NAND flash type: MLC**
- **Performance**
 - Burst transfer rate: 600 MB/sec
 - Sustained read: up to 550 MB/sec
 - Sustained write: up to 480 MB/sec
 - Random read 4K: up to 75,000 IOPS
 - Random write 4K: up to 70,000 IOPS
- **Intelligent endurance design**
 - Built-in hardware ECC, Low-Density Parity-Check (LDPC) Code
 - Global wear-leveling scheme together with dynamical block allocation to significantly increase the lifetime of a flash device and optimize the disk performance
 - Flash bad-block management
 - *Power Failure Management*
 - *ATA Secure Erase*
 - *SMART Command*
 - *Trim Command*
- **Connector Type**
 - 7-pin signal connector
 - 15-pin power connector
- **Form factor**
 - 1.8 inch (78.5 x 54 x 5, unit: mm)
 - Net weight: 28.63g ± 5%
- **RoHS compliant**
- **Endurance in Terabytes Written (TBW)**
 - 32 GB: 69 TBW
 - 64 GB: 139 TBW
 - 128 GB: 278 TBW
 - 256 GB: 198 TBW
 - 512 GB: 540 TBW
- **Temperature ranges**
 - Operation:
 - Standard: 0°C to 70°C
 - Industrial: -40°C to 85°C
 - Storage: -40°C to 100°C

* Varies between different capacities. The values shown for Performances and Power Consumption are typical and may vary between different configurations and platforms.

Table of Contents

1 Product Description.....	4
1.1 General Description.....	4
1.2 Functional Description.....	4
1.3 Capacity Specification.....	5
1.4 Performance Specification.....	5
1.5 Pin Assignments.....	6
2. Software Interface.....	7
2.1 Command Set.....	7
3. Flash Management.....	8
3.1 Error Correction/Detection.....	8
3.2 Wear Leveling.....	8
3.3 Power Failure Management.....	8
3.4 ATA Secure Erase.....	8
3.5 S.M.A.R.T. Technology.....	8
3.6 TRIM Command Support.....	10
3.7 SATA Power Management.....	10
4. Environmental Specifications.....	11
4.1 Environments.....	11
4.2 Mean Time Between Failures (MTBF).....	11
4.3 Certification and Compliance.....	11
4.4 Endurance.....	12
5. Electrical Specification.....	13
5.1 Operating Voltage.....	13
5.2 Power Consumption.....	13
6. Physical Characteristics.....	14
6.1 Dimensions.....	14
7. Product Ordering Information.....	15
7.1 Product Code Designations.....	15
7.2 Valid Combinations.....	16
8. Revision History.....	17

SATA Flash Drive – 1.8”

FMS-SF18AxxxG-XKM



1 Product Description

1.1 General Description

Fortasa's SF18A-KM is a high-performance, SATA interface, solid state drive (SSD) designed to replace a conventional SATA hard disk drive. SF18A-KM supports standard SATA protocol and can be plugged into a standard SATA connector commonly found in rugged laptops, military devices, thin clients, Point of Sale (POS) terminals, telecom, medical instruments, surveillance systems and industrial PCs. Fortasa SF18A-KM Series is the best drop-in replacement for high-maintenance HDD where reliability is of a major importance.

The SF18A-KM drive offers capacities of up to 512 gigabytes, providing full support for the SATA 3 high-speed interface standard. It can operate at sustained access rates of up to 600 megabytes per second, which is much faster than other solid-state or traditional HDD SATA drives currently available on the market. **Manufactured using Industrial Temperature rated MLC NAND-flash, this SSD can work in highly demanding environment and withstand wide range of operating temperature from -40°C to +85°C (for certain capacities only).**

SF18A-KM offers high reliability global data wear-leveling scheme to allow uniform use of all storage blocks, increasing the lifetime of Flash media and optimizing drive performance. The SF18A-KM also offers Self-Monitoring Analysis and Reporting Technology (S.M.A.R.T.) feature that follows the SATA Rev. 2.5, ATA/ATAPI-7 specifications and uses the standard SMART command B0h to read data from the drive. This capability monitors the drive accesses and provides the host with vital information about drive condition to schedule maintenance and service times. Additionally, SF18A-KM drive is equipped with a built-in thermal sensor (available on the Industrial temperature model only) to monitor the temperature of the SSD via S.M.A.R.T commands to prevent overheating.

1.2 Functional Description

The SF18A-KM drive includes a single-chip SATA Flash Controller and the flash media. The controller integrates the flash management unit to support multi-channel, multi-bank flash arrays.

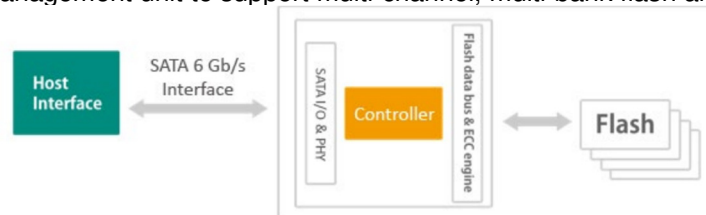

1.3 Capacity Specification

Standard capacity specification of the SATA Flash Drive product is shown in Table 1-1. The table lists the specific capacity and the default numbers of heads, sectors and cylinders (CHS) for each product line.

Table 1-1: Capacity specifications

Capacity	Total Bytes	Cylinders	Heads	Sectors	Max LBA
32GB	32,017,047,552	16383 ¹	16	63	62,533,296
64GB	64,023,257,088	16383 ¹	16	63	125,045,424
128GB	128,035,676,160	16383 ¹	16	63	250,069,680
256GB	256,060,514,304	16383 ¹	16	63	500,118,192
512GB	512,110,190,592	16383 ¹	16	63	1,000,215,216

1. Cylinders, heads or sectors are not applicable for these capacities. Only LBA addressing applies.

Please contact factory for any non-listed SATA Flash Drive capacity or custom CHS requirement.

1.4 Performance Specification

Performances of the SATA Flash Drive are listed in Table 1-2.

Table 1-2: Standard Performance specifications

Capacity \ Performance	32GB	64GB	128GB	256GB	512GB
Sustained read (MB/s)	340	375	510	500	500
Sustained write (MB/s)	100	85	380	470	480
Random Read IOPS (4K)	48,000	45,000	68,000	75,000	75,000
Random Write IOPS (4K)	40,000	40,000	62,000	70,000	70,000

Note: Performance varies from flash configurations or host system settings.
 IOPS: measured on 8GB span (16777216 sectors Disk Size), 32 Outstanding I/Os (QD=32), Full Random Data pattern, 4KB Align I/Os and test durations 15 minutes.

1.5 Pin Assignments

Figure 1-2: Micro-SATA connectors

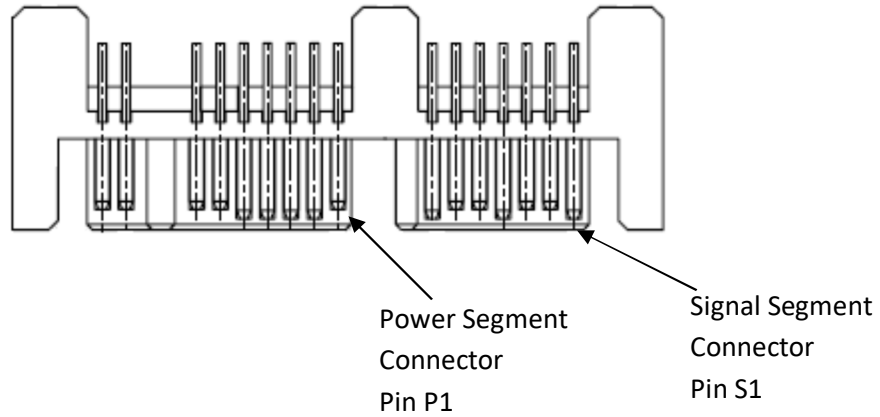

Table 1-3: Signal Segment

Pin	Signal	Description
S1		Ground
S2	RxP	Serial Data Receiver
S3	RxN	
S4		Ground
S5	TxN	Serial Data Transmitter
S6	TxP	
S7		Ground

Table 1-4: Power Segment

Pin	Signal
P1	3.3V
P2	3.3V
P3	Ground
P4	Ground
P5	5V
P6	5V
P7	GND
P8	NC
P9	NC

2. Software Interface

2.1 Command Set

Table 2-1 summarizes the command set with the paragraphs that follow describing the individual commands and the task file for each.

Table 2-1: Command set

Command	Code	Command	Code
Check-Power-Mode	E5H	Security-Disable-Password	F6H
Data Set Management	06h	Security-Erase-Prepare	F3H
DCO	B1h	Security-Erase-Unit	F4H
Download Microcode PIO	92h	Security-Freeze-Lock	F5H
Download Microcode DMA	93h	Security-Set-Password	F1H
Execute-Drive-Diagnostic	90H	Security-Unlock	F2H
Flush-Cache	E7H	Seek	7XH
Identify-Drive	ECH	Set-Features	EFH
Idle	E3H	Set MAX Address	F9H
Idle-Immediate	E1H	Set MAX Address EXT	37H
Initialize-Drive-Parameters	91H	Set-Multiple-Mode	C6H
Read Buffer	E4	Set-Sleep-Mode	E6H
Read DMA (W retry)	C8H	SMART	B0H
Read DMA (W/O retry)	C9H	Stand-By	E2H
Read DMA EXT	25H	Stand-By-Immediate	E0H
Read FPDMA Queued	60H	Write Buffer	E8H
Read Log EXT	2FH	Write DMA	CAH or CBH
Read-Multiple	C4H	Write DMA EXT	35H
Read-Multiple EXT	29H	Write DMA FUA EXT	3DH
Read Native Max Address	F8H	Write FPDMA Queued	61H
Read Native Max Ext	27H	Write Log EXT	3FH
Read-Sector(s)	20H or 21H	Write-Multiple	C5H
Read-Sector(s) EXT	24H	Write-Multiple EXT	39H
Read-Verify-Sectors	40H or 41H	Write-Multiple FUA EXT	CEH
Read-Verify-EXT	42H	Write-Sector(s)	30H or 31H
Recalibrate	10H	Write-Sector(s) EXT	34H
		Write Uncorrectable	45H

3. Flash Management

3.1 Error Correction/Detection

SF18A-KM implements a hardware ECC scheme, based on the Low Density Parity Check (LDPC). LDPC is a class of linear block error correcting code which has apparent coding gain over BCH code because LDPC code includes both hard decoding and soft decoding algorithms. With the error rate decreasing, LDPC can extend SSD endurance and increase data reliability while reading raw data inside a flash chip.

3.2 Wear Leveling

All NAND flash devices are limited by a finite number of write cycles. Under a standard file system, frequent file table updates are mandatory. As a painful side effect of OS file overhead, some areas of flash address space wear out faster than others. As these certain sections get a substantially higher write occurrence the whole SATA Flash Drive can wear out very quickly. This uneven wear would significantly reduce the lifetime of the whole device, even if majority of the Flash sectors are far from the write cycle limit. Fortasa's SATA Flash Drive products offer advanced data wear leveling which distributes Flash writes evenly across the SATA Flash Drive memory space. By utilizing this advanced wear leveling feature, the lifetime of the media can be significantly extended.

3.3 Power Failure Management

The Low Power Detection on the Flash controller initiates cached data saving before the power supply to the device drops too low for operation. This feature prevents the device from system crash and ensures data integrity during an unexpected brownout. This feature makes sure that there are no catastrophic failures of the SATA Flash Drive due to system power glitches.

3.4 ATA Secure Erase

Accomplished by the Secure Erase (SE) command, which added to the open ANSI standards that control disk drives, "ATA Secure Erase" is built into the disk drive itself and thus far less susceptible to malicious software attacks than external software utilities. It is a positive easy-to-use data destroy command, amounting to electronic data shredding. Executing the command causes a drive to internally completely erase all possible user data. This command is carried out within disk drives, so no additional software is required. The erase process will not stop until it is completed. In case of power failure, the erase process will continue when the power is reapplied to the device.

3.5 S.M.A.R.T. Technology

S.M.A.R.T. is an acronym for Self-Monitoring, Analysis and Reporting Technology, an open standard allowing disk drives to automatically monitor their own health and report potential problems. It protects the user from unscheduled downtime by monitoring and storing critical drive performance and calibration parameters. Ideally, this should allow taking proactive actions to prevent impending drive failure.

Code	SMART Subcommand
D0h	READ DATA
D1h	READ ATTRIBUTE THRESHOLDS
D2h	Enable/Disable Attribute Autosave
D4h	Execute Off-line Immediate
D5h	Read Log (optional)
D6h	Write Log (optional)
D8h	Enable Operations
D9h	Disable operations
DAh	Return Status

SATA Flash Drive – 1.8”
FMS-SF18AxxxG-XKM



General SMART attribute structure

Byte	Description
0	ID (Hex)
1 – 2	Status flag
3	Value
4	Worst
5*-11	Raw Data

*Byte 5: LSB

SMART attribute ID list

ID (Hex)	Attribute Name
9 (0x09)	Power-on hours
12 (0x0C)	Power cycle count
163 (0xA3)	Max. erase count
164 (0xA4)	Avg. erase count
166 (0xA6)	Total later bad block count
167 (0xA7)	SSD Protect Mode (vendor specific)
168 (0xA8)	SATA PHY Error Count
171 (0xAB)	Program Fail Count
172 (0xAC)	Erase Fail Count
175 (0xAF)	Bad Cluster Table Count
192 (0xC0)	Unexpected Power Loss Count
194 (0xC2)	Temperature
231 (0xE7)	Lifetime Left
241 (0xF1)	Total sectors of write

3.6 TRIM Command Support

Over time the performance of SSD degrades as user continually writes and erases data. The ATA-TRIM command “formats” the SSD to optimize the drive performance. A TRIM enabled SSD running an OS with TRIM support will stay closer to its peak performance without much performance variance.

3.7 SATA Power Management

The SF18A-KM devices support the following SATA power saving modes:

- ACTIVE: PHY ready, full power, Tx & Rx operational
- PARTIAL: Reduces power, resumes in under 10 μs (microseconds)
- SLUMBER: Reduces power, resumes in under 10 ms (milliseconds)
- HIPM: Host-Initiated Power Management
- DIPM: Device-Initiated Power Management
- AUTO-SLUMBER: Automatic transition from partial to slumber.

Note:

1. The behaviors of power management features depend on host/device settings.

4. Environmental Specifications

4.1 Environments

Environmental specification of the SATA Flash Drive series follows the MIL-STD-810F standard as shown in Table 4-1.

Table 4-1: Environmental specifications

Environment		Specification
Temperature	Operation	0°C to +70°C (standard); -40°C to +85°C (industrial)
	Storage	-40°C to +100°C
Vibration		Operating: 7.69(Grms), 20~2000(Hz)/random (compliant with MIL-STD-810G) Non-operating: 4.02(Grms), 15~2000(Hz)/random (compliant with MIL-STD-810G)
Shock-		Operating: Acceleration, 50(G)/11(ms)/half sine (compliant with MIL-STD-202G) Non-operating: Acceleration, 1,500(G)/0.5(ms)/half sine (compliant with MIL-STD-883K)

4.2 Mean Time Between Failures (MTBF)

Mean Time Between Failures (MTBF) is predicted based on reliability data for the individual components in the SF18A-KM drive. Based on provided component data, SATA Flash Drive is rated at more than 2,000,000 hours.

Notes about the MTBF:

The MTBF is predicated and calculated based on “Telcordia Technologies Special Report, SR-332, Issue 2” method.

4.3 Certification and Compliance

The SF18A-KM complies with the following standards:

- CE
- FCC
- RoHS
- MIL-STD-810F

SATA Flash Drive – 1.8”

FMS-SF18AxxxG-XKM



4.4 Endurance

The endurance of a storage device is predicted by a JEDEC approved test methodology. The data, reported in TeraBytes Written, is based on several factors related to device architecture and product usage, such as the amount of data written into the drive, block management conditions, and daily workload for the drive. Please contact Sales to learn more about the TBW analysis and calculations.

Capacity	TBW
32GB	28
64GB	52
128GB	100
256GB	198
512GB	540

Notes:

- The measurement assumes the data written to the SSD for test is under a typical and constant rate.
- The measurement follows the standard metric: 1 TB (Terabyte) = 1000 GB.
- The estimated values are based on JEDEC Enterprise endurance workload comprised of random data with the payload size distribution with sequential write behavior.

5. Electrical Specification

5.1 Operating Voltage

Caution: Absolute Maximum Stress Ratings – Applied conditions greater than those listed under “Absolute Maximum Stress Ratings” may cause permanent damage to the device. This is a stress rating only and functional operation of the device at these conditions or conditions greater than those defined in the operational sections of this data sheet is not implied. Exposure to absolute maximum stress rating conditions may affect device reliability.

Table 5-1: Operating range

Range	Ambient Temperature	Conditions
Standard	0°C to +70°C	3.3V ± 5% (3.135-3.465V) / 5V ± 5% (4.75-5.25V)
Industrial	-40°C to +85°C	3.3V ± 5% (3.135-3.465V) / 5V ± 5% (4.75-5.25V)

5.2 Power Consumption

Table 5-2 lists the SF18A-KM power consumption.

Table 5-2 SF18A-KM power consumption (typical) @ 3.3V

Capacity	32GB	64GB	128GB	256GB	512GB
Performance					
Active Mode (mA)	500	620	680	780	800
Idle Mode (mA)	100	100	100	100	100

Table 5-3 SF18A-KM power consumption (typical) @ 5.0V

Capacity	32GB	64GB	128GB	256GB	512GB
Performance					
Active Mode (mA)	500	500	500	510	510
Idle Mode (mA)	70	70	70	70	70

Note: Power consumptions may vary depending on settings and platforms.

Power consumption is measured using CrystalDiskMark 8.0.4 with file size 1,000MB.

6. Physical Characteristics

6.1 Dimensions

Figure 6-1 illustrates the overall dimensions of the SF18A-KM drive, as listed in Table 6-1.

Table 6-1 SF18A-KM dimensions

Dimension	Millimeters (mm)
Height	5.0 ± 0.20
Width	54.0 ± 0.20
Length	78.50 ± 0.30

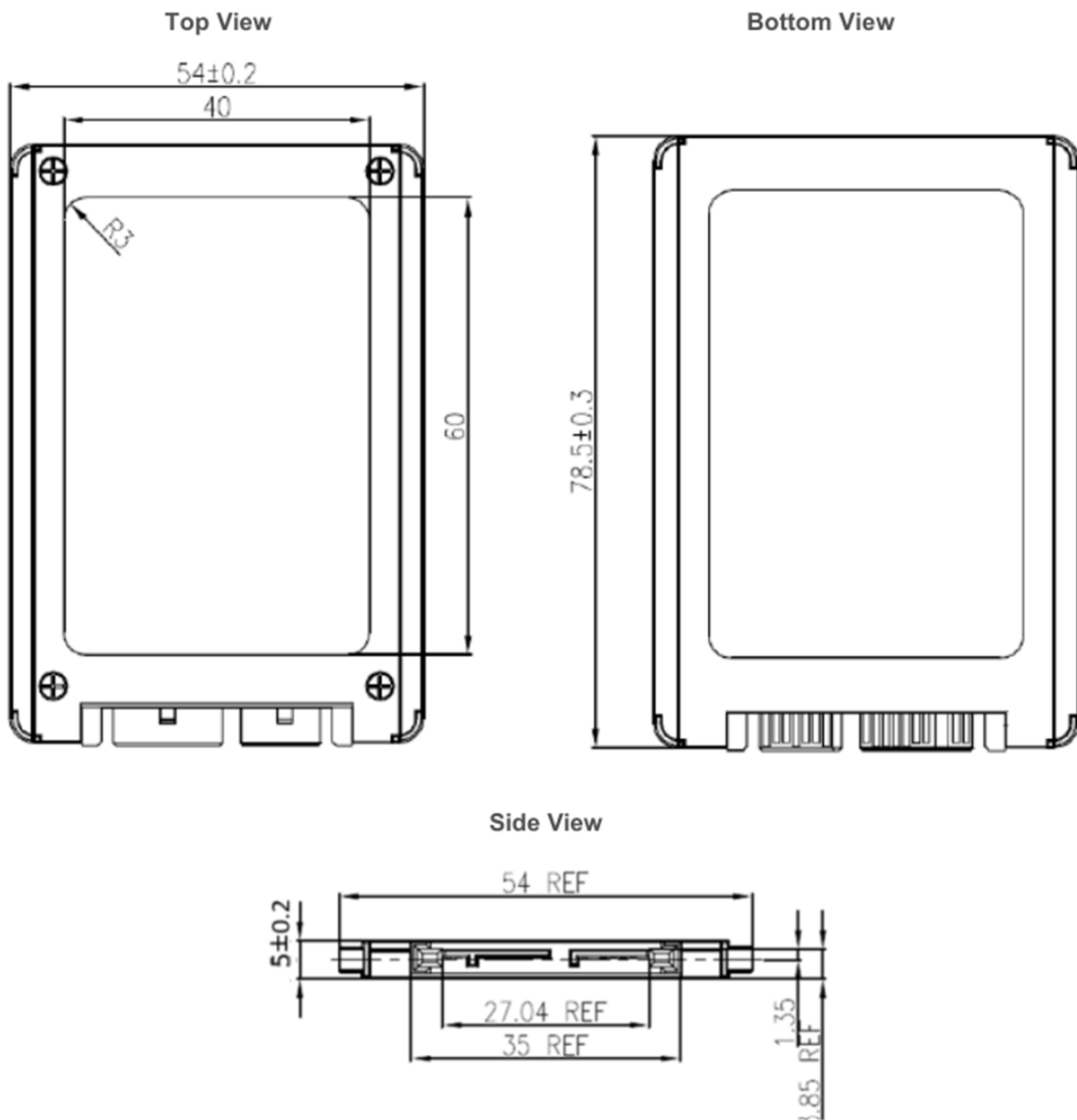

7. Product Ordering Information

7.1 Product Code Designations

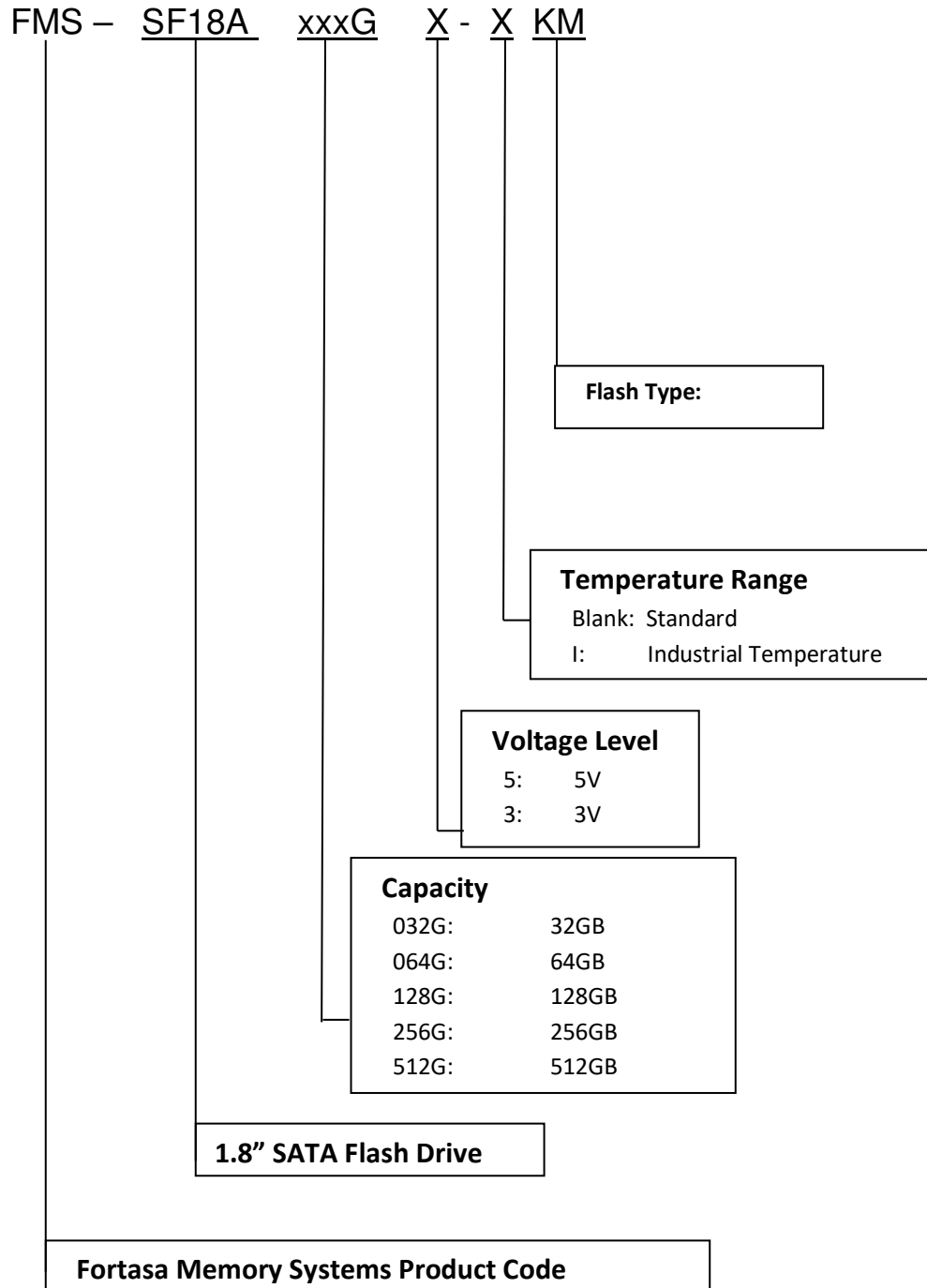

7.2 Valid Combinations

SF18A-KM - 3.3V

Capacity	Standard Temperature Model Numbers	Industrial Temperature Model Numbers
32GB	FMS-SF18A032G3-KM	FMS-SF18A032G3-IKM
64GB	FMS-SF18A064G3-KM	FMS-SF18A064G3-IKM
128GB	FMS-SF18A128G3-KM	FMS-SF18A128G3-IKM
256GB	FMS-SF18A256G3-KM	FMS-SF18A256G3-IKM
512GB	FMS-SF18A512G3-KM	FMS-SF18A512G3-IKM

SF18A-KM - 5V

Capacity	Standard Temperature Model Numbers	Industrial Temperature Model Numbers
32GB	FMS-SF18A032G5-KM	FMS-SF18A032G5-IKM
64GB	FMS-SF18A064G5-KM	FMS-SF18A064G5-IKM
128GB	FMS-SF18A128G5-KM	FMS-SF18A128G5-IKM
256GB	FMS-SF18A256G5-KM	FMS-SF18A256G5-IKM
512GB	FMS-SF18A512G5-KM	FMS-SF18A512G5-IKM

Note: Valid combinations are those products in mass production or will be in mass production. Consult your Fortasa sales representative to confirm availability of valid combinations and to determine availability of new product combinations



8. Revision History

Revision	Date	Description	Comments
1.0	7/29/2025	Initial Release	

Copyright © 2025 Fortasa Memory Systems, Inc. All Rights Reserved.

Information in this document is subject to change without prior notice.

Fortasa name and the Fortasa logo are trademarks or registered trademarks of
Fortasa Memory Systems, Inc.

Other brands, names, trademarks or registered trademarks may be claimed as the property of
their respective owners.