

RoHS Compliant
USB Disk Module Series
Datasheet for UDM2P MLC NAND Based Module

March 23, 2017

Revision 1.9



***This Specification Describes the Features and Capabilities of
the Standard and Industrial Temperature
USB Disk Modules***

***Please Contact Fortasa Memory Systems Sales for any
Custom Features Required For Your Specific Application***



1111 Triton Dr
Suite 100
Foster City, CA 94404 USA
888-367-8588
www.fortasa.com

Features:

- **USB2.0 High-Speed and USB1.1 Full-Speed Compatible interface**
- **Module Capacity**
 - 4, 8, 16, 32, 64 GB
- **Fast sustained read performance**
 - Sustained read: up to 33 MB/s
- **Fast sustained write performance**
 - Sustained write: up to 16 MB/s
- **Intelligent USB Module**
 - Dynamic wear-leveling algorithms to increase life expectancy of flash media
 - BCH (24-bit) Error Detection Code/Error Correction Code (EDC/ECC)
 - Power interruption data protection circuitry
- **NAND flash type: MLC**
- **Zero Power Data Retention**
 - Batteries not required for data storage
- **Support Ready Boost for Windows Vista**
- **Support boot-up function for OS**
 - Windows XP Embedded
 - Windows CE
 - Linux
- **Temperature ranges**
 - 0°C to 70°C for operation (Standard Temperature)
 - -40°C to 85°C for operation (Industrial Temperature)
 - -40°C to 100°C for storage
- **Low power consumption (typical)**
 - Active mode: 175 mA
 - Sleep mode: 80 mA
- **Connector**
 - 10-pin (2x5) female header
- **RoHS Compliant**

Table of Contents

Features:	2
1. General Description	4
1.1 Performance-optimized Controller	4
1.1.1 Error Correction Code (ECC).....	4
1.1.2 Wear-Leveling.....	4
1.1.3 Write Protection Mode (optional).....	4
1.1.4 S.M.A.R.T. Technology	4
2. Functional Block Diagram.....	5
3. Pin Assignment	6
3.1 Type A, B and C.....	6
3.2 Type D.....	7
4. Technical Specifications	8
4.1 Capacity Specifications	8
4.2 Functional Specifications	8
4.3 Environmental Specifications.....	8
5. Electrical Specification	9
6. Physical Dimension	10
6.1 Horizontal Design	10
6.1.1 Type A (STD 90 Degrees).....	10
6.1.2 Type B (STD 90D-MH) Standard 90 Degree with Mounting Header	11
6.1.3 Type C (STD 90D-MS) Standard 90 Degree with Mounting Screw	12
6.2 Vertical Design.....	13
6.2.1 Type D (STD 180D) Standard 180 Degree	13
7. Product Ordering Information.....	14
7.1 Product Code Designation.....	14
7.2 Valid Combinations.....	15
7.2.1 Type A (STD 90D).....	15
7.2.2 Type B (STD 90D-MH)	15
7.2.3 Type C (STD 90D-MS).....	15
7.2.4 Type D (STD 180D).....	16
8. Revision History	17

1. General Description

Fortasa USB Disk Module (UDM) is a high performance, embedded solid state drive (SSD) designed to replace a conventional IDE hard disk drive. UDM SSD can be plugged into a standard Embedded USB connector commonly found in desktops, portable PC systems and industrial PC systems. This product is well suited for embedded flash storage applications offering new and expanded functionality small form factor, better performance and increased reliability.

1.1 Performance-optimized Controller

The heart of an UDM is the USB controller, which translates standard USB signals into the data and controls of the flash media. This proprietary USB controller is specifically designed to attain high data throughput from host to flash.

1.1.1 Error Correction Code (ECC)

The UDM uses BCH Error Detection Code (EDC) and Error Correction Code (ECC) algorithms which corrects up to 24 random single-bit errors for each 1024 byte block of data. High performance is achieved through hardware-based error detection and correction.

1.1.2 Wear-Leveling

Flash memory can be erased a limited number of times, This number is called the erase cycle limit, or write endurance limit, The erase cycle limit applies to each individual erase block in the flash device. In a typical application, and especially if a file system is used, specific pages are constantly updated (e.g. the page that contains the FAT, registry, etc.). Without any special handling, these pages would wear out more rapidly than other pages, reducing the lifetime of the entire flash.

To overcome this inherent deficiency, Fortasa's USB-Disk Module (UDM) uses wear-leveling algorithm. This wear-leveling method ensures that consecutive writes of a specific sector are not written physically to the same page in the flash. This algorithm spreads flash media usage evenly across all pages, thereby maximizing flash lifetime.

1.1.3 Write Protection Mode (optional)

An optional write protection switch feature prevents the stored data from inadvertent system writes or erases, and viruses.

1.1.4 S.M.A.R.T. Technology

S.M.A.R.T. is an acronym for Self-Monitoring, Analysis and Reporting Technology, an open standard allowing disk drives to automatically monitor their own health and report potential problems. It protects the user from unscheduled downtime by monitoring and storing critical drive performance and calibration parameters. Ideally, this should allow taking proactive actions to prevent impending drive failure.

2. Functional Block Diagram

The USB-Disk Module (UDM) contains a controller, embedded firmware, and Flash Media with a female connector. The UDM interfaces with the host system allowing data to be written to and read from the Flash Media.

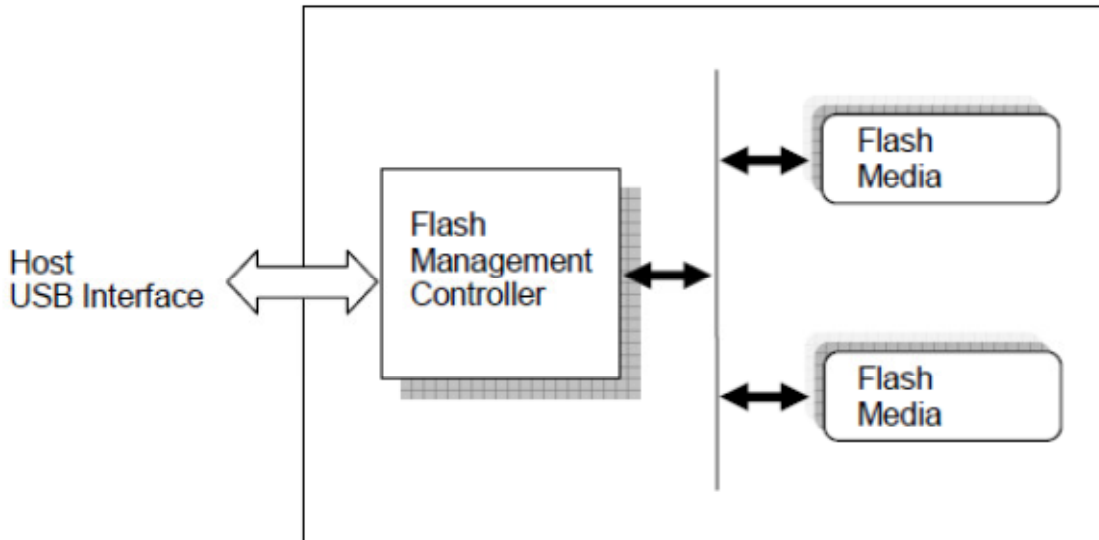

Figure 2-1: Functional block diagram

3. Pin Assignment

This section provides information on pin assignments and signal descriptions.

3.1 Type A, B and C

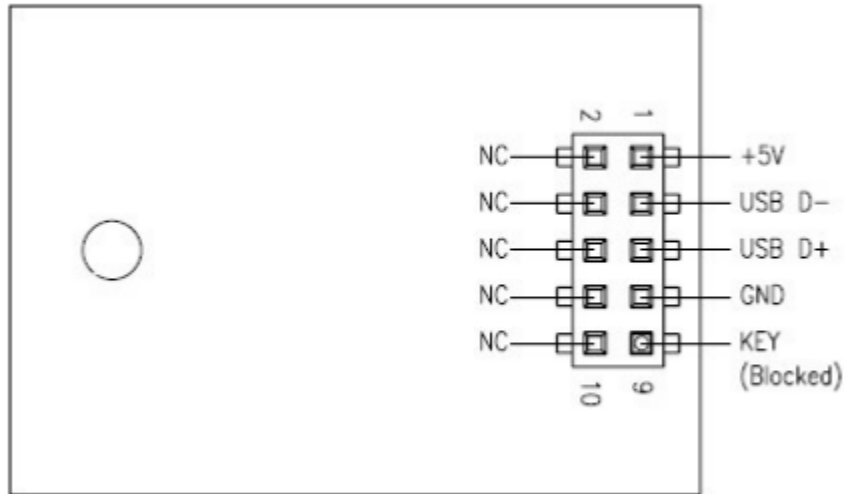

Table 3-1: Pin Assignment of the 10-pin configuration in Type A, B and C Modules

Pin	Signal Description	Pin	Signal Description
1	Vcc (5V)	2	NC
3	USB D-	4	NC
5	USB D+	6	NC
7	GND	8	NC
9	Key (Blocked)	10	NC

3.2 Type D

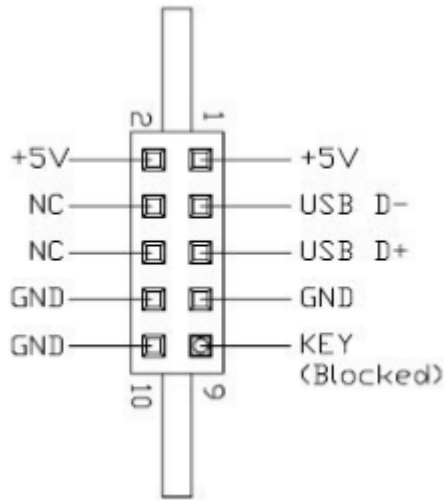

Table 3-2: Pin Assignment of the 10-pin configuration in Type D

Pin	Signal Description	Pin	Signal Description
1	Vcc (5V)	2	Vcc (5V)
3	USB D-	4	NC
5	USB D+	6	NC
7	GND	8	GND
9	Key (Blocked)	10	GND

4. Technical Specifications

4.1 Capacity Specifications

The OEM USB-Module product family is available in the following capacities.

Table 4-1: Capacity Specification

Capacity	Total Bytes
4GB	4,001,382,400
8GB	8,011,153,408
16GB	16,030,662,656
32GB	32,061,325,312
64GB	64,139,362,304

Note: The number of total bytes may vary depending on the file system in use.

4.2 Functional Specifications

Table 4-2: Performance Specifications

Performance	Capacity	4GB	8GB	16GB	32GB	64GB
	Sustained read (MB/s)		30	34	39	30
Sustained write (MB/s)		10	8	17	19	18

4.3 Environmental Specifications

Environmental specification of the USB-Disk Module (UDM) product family which follows the MIL-STD-810F standards is available as shown in Table 4-2.

Table 4-2: Environmental Specifications

Environment		Specification
Temperature	Operation	0°C to 70°C (standard); -40°C to 85°C (industrial)
	Storage	-40°C to 100°C
Vibration		Sine wave 10 Hz to 500 Hz, 50 m/s ² , 3 axes (IEC 68-2-6, non-operating)
Shock		Half sine wave 50G, 6 axes, 18 times (IEC 68-2-27, non-operating)

5. Electrical Specification

Caution: Absolute Maximum Stress Ratings – Applied conditions greater than those listed under “Absolute Maximum Stress Ratings” may cause permanent damage to the device. This is a stress rating only and functional operation of the device at these conditions or conditions greater than those defined in the operational sections of this data sheet is not implied. Exposure to absolute maximum stress rating conditions may affect device reliability.

Table 5-1: Operating range

Range	Ambient Temperature	5V
Standard	0°C to +70°C	4.5-5.5V
Industrial	-40°C to +85°C	

Table 5-2: Absolute maximum power pin stress ratings

Parameter	Symbol	Min	Max
Power Supply Input	V_{DD}	-0.3V	5.5V
Voltage on any flash media interface pin with respect to GND	V	-0.3V	5.8V

Table 5-3: AC Characteristics Full Speed

Parameter	Symbol	Min	Typ	Max	Unit
Rise Time	T_{FR}	4	-	20	ns
Fall Time	T_{FF}	4	-	20	ns
Differential Rise and Fall Time Matching	T_{FRFM}	90	-	111.11	%
Driver Output Resistance	Z_{DRV}	28	-	44	Ω

Table 5-4: AC Characteristics High Speed

Parameter	Symbol	Min	Typ	Max	Unit
Rise Time (10%-90%)	T_{HSR}	500	-	-	ps
Fall Time (10%-90%)	T_{HSF}	500	-	-	ps
Driver Output Resistance	Z_{HSDRV}	40.5	-	49.5	Ω

6. Physical Dimension

6.1 Horizontal Design

6.1.1 Type A (STD 90 Degrees)

Length	28.8mm	Width	26.65mm	Height (Max)	10.5 mm
--------	--------	-------	---------	--------------	---------

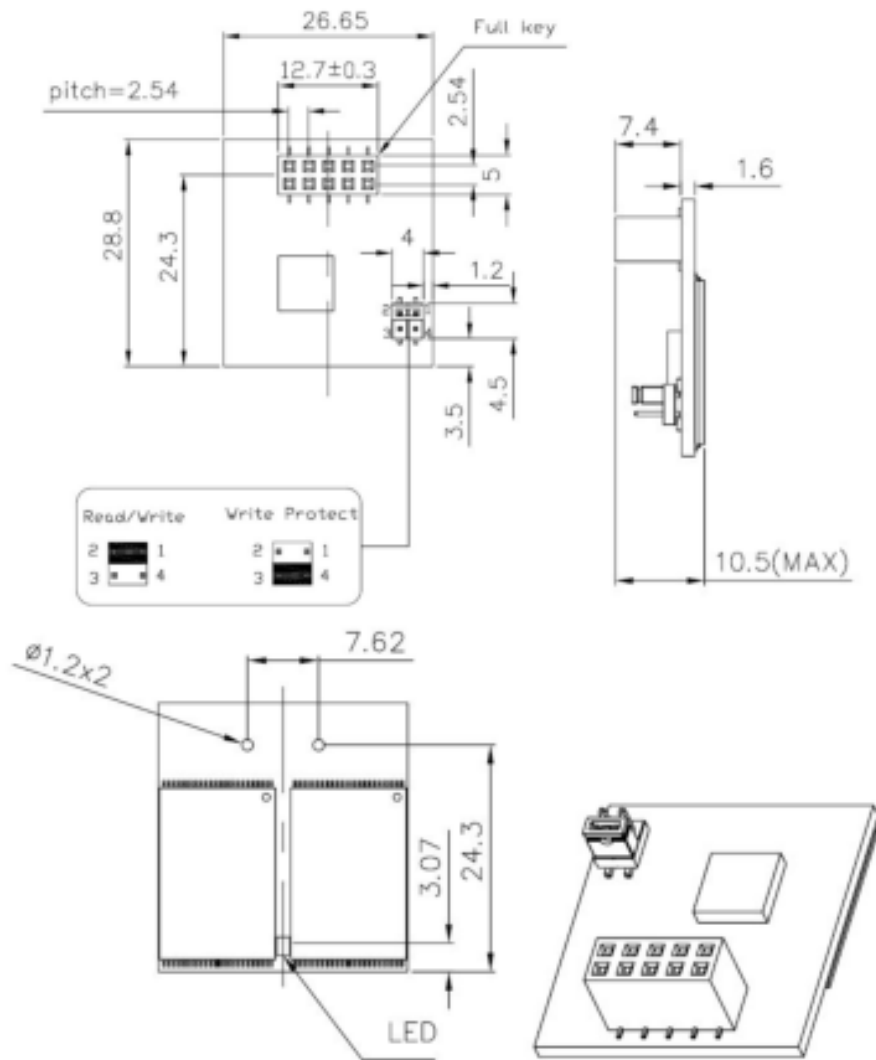

Unit: mm
 Tolerance: ± 0.20

USB Disk Module

FMS-UMxxxxXXXXS-XXXXX



6.1.2 Type B (STD 90D-MH)

Standard 90 Degree with Mounting Header

Length	37.8mm	Width	26.65mm	Height (Max)	10.5 mm
--------	--------	-------	---------	--------------	---------

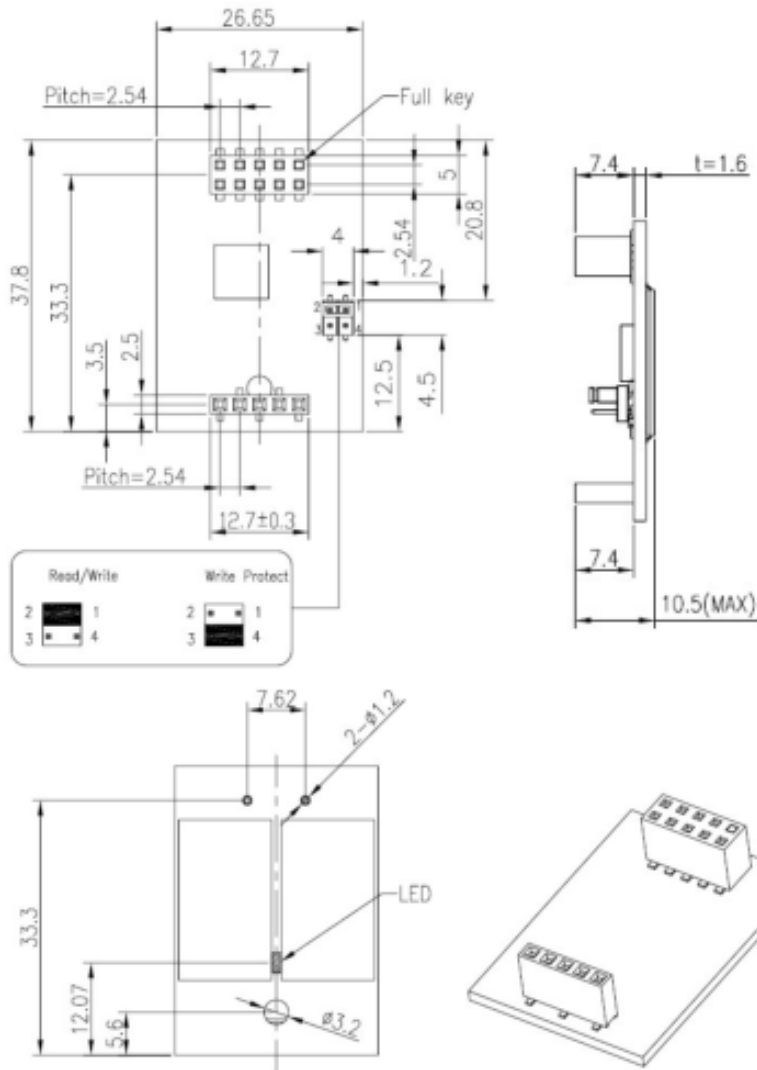

Unit: mm
Tolerance: ± 0.20

USB Disk Module

FMS-UMxxxxXXXXS-XXXXX



6.1.3 Type C (STD 90D-MS)

Standard 90 Degree with Mounting Screw

Length	37.8mm	Width	26.65mm	Height (Max)	10.5 mm
--------	--------	-------	---------	--------------	---------

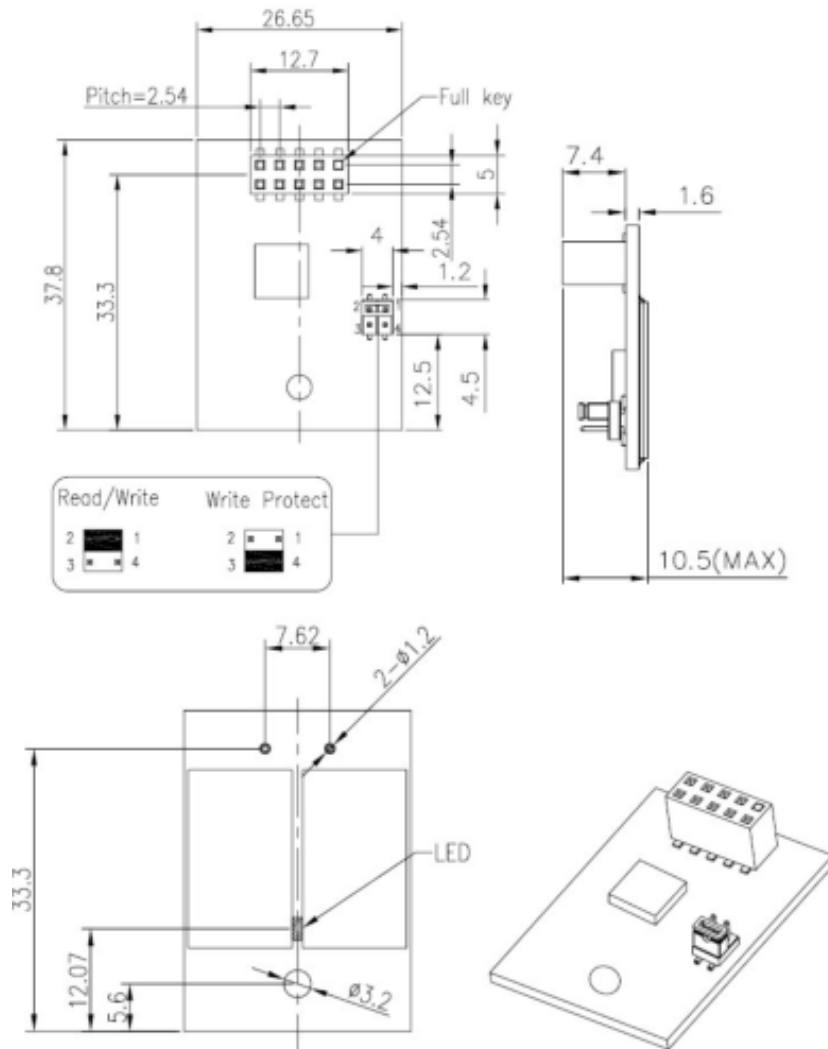

Unit: mm
Tolerance: ± 0.20

USB Disk Module FMS-UMxxxxXXXXS-XXXXX



6.2 Vertical Design

6.2.1 Type D (STD 180D) Standard 180 Degree

Length	36.8 mm	Width	26.65 mm	Height (Max)	8.5 mm
--------	---------	-------	----------	--------------	--------

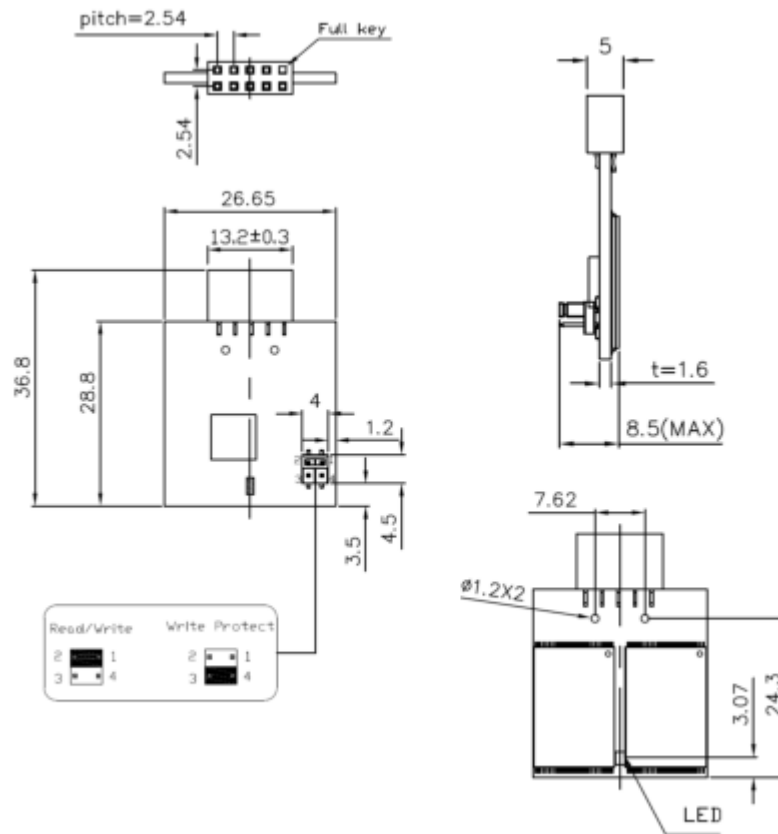

Unit: mm
Tolerance: ± 0.20

7. Product Ordering Information

7.1 Product Code Designation

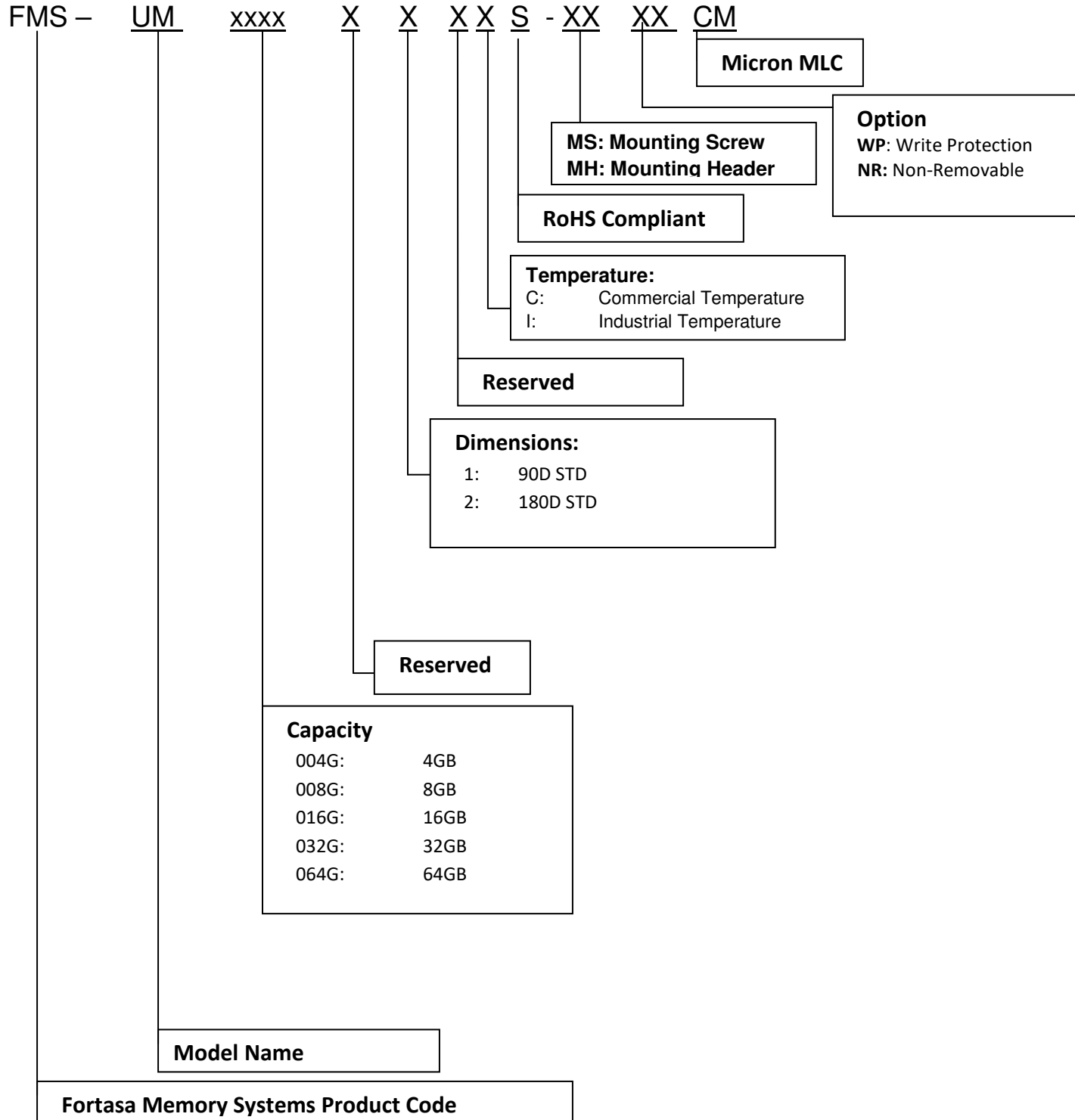

7.2 Valid Combinations

7.2.1 Type A (STD 90D)

Standard 90 Degree

Capacity	Standard Temperature	Industrial Temperature
256MB	FMS-UM256MK10CS-2CM	FMS-UM256MD10IS-2CM
512MB	FMS-UM512MK10CS-2CM	FMS-UM512MD10IS-2CM
1GB	FMS-UM001GK10CS-2CM	FMS-UM001GD10IS-2CM
2GB	FMS-UM002GK10CS-2CM	FMS-UM002GD10IS-2CM
4GB	FMS-UM004GK10CS-2CM	FMS-UM004GD10IS-2CM
8GB	FMS-UM008GK10CS-2CM	FMS-UM008GD10IS-2CM
16GB	FMS-UM016GK10CS-2CM	FMS-UM016GD10IS-2CM
32GB	FMS-UM032GK10CS-2CM	FMS-UM032GD10IS-2CM

7.2.2 Type B (SCMD 90D-MH)

Standard 90 Degree – Mounting Header

Capacity	Standard Temperature	Industrial Temperature
256MB	FMS-UM256MK10CS-2MHCM	FMS-UM256MD10IS-2MHCM
512MB	FMS-UM512MK10CS-2MHCM	FMS-UM512MD10IS-2MHCM
1GB	FMS-UM001GK10CS-2MHCM	FMS-UM001GD10IS-2MHCM
2GB	FMS-UM002GK10CS-2MHCM	FMS-UM002GD10IS-2MHCM
4GB	FMS-UM004GK10CS-2MHCM	FMS-UM004GD10IS-2MHCM
8GB	FMS-UM008GK10CS-2MHCM	FMS-UM008GD10IS-2MHCM
16GB	FMS-UM016GK10CS-2MHCM	FMS-UM016GD10IS-2MHCM
32GB	FMS-UM032GK10CS-2MHCM	FMS-UM032GD10IS-2MHCM

7.2.3 Type C (SCMD 90D-MS)

Standard 90 Degree Mounting Screw

Capacity	Standard Temperature	Industrial Temperature
256MB	FMS-UM256MK10CS-2MSCM	FMS-UM256MD10IS-2MSCM
512MB	FMS-UM512MK10CS-2MSCM	FMS-UM512MD10IS-2MSCM
1GB	FMS-UM001GK10CS-2MSCM	FMS-UM001GD10IS-2MSCM
2GB	FMS-UM002GK10CS-2MSCM	FMS-UM002GD10IS-2MSCM
4GB	FMS-UM004GK10CS-2MSCM	FMS-UM004GD10IS-2MSCM
8GB	FMS-UM008GK10CS-2MSCM	FMS-UM008GD10IS-2MSCM
16GB	FMS-UM016GK10CS-2MSCM	FMS-UM016GD10IS-2MSCM
32GB	FMS-UM032GK10CS-2MSCM	FMS-UM032GD10IS-2MSCM

7.2.4 Type D (STD 180D)

Standard Profile - 180 Degree

Capacity	Standard Temperature	Industrial Temperature
256MB	FMS-UM256MK42CS-2CM	FMS-UM256ML42IS-2CM
512MB	FMS-UM512MK42CS-2CM	FMS-UM512ML42IS-2CM
1GB	FMS-UM001GK42CS-2CM	FMS-UM001GL42IS-2CM
2GB	FMS-UM002GK42CS-2CM	FMS-UM002GL42IS-2CM
4GB	FMS-UM004GK42CS-2CM	FMS-UM004GL42IS-2CM
8GB	FMS-UM008GK42CS-2CM	FMS-UM008GL42IS-2CM
16GB	FMS-UM016GK42CS-2CM	FMS-UM016GL42IS-2CM
32GB	FMS-UM032GK42CS-2CM	FMS-UM032GL42IS-2CM

8. Revision History

Revision	Description	Date
1.0	Official Release	December 13, 2011
1.1	Revised Capacity Specifications	May 10, 2012
1.2	Added 64GB model	June 29, 2012
1.3	Updated Fortasa Corporate Information	August 30, 2012
1.4	Updated Product Ordering Information	February 3, 2015
1.5	Added Industrial Temperature Support	March 10, 2015
1.6	Revised part numbering	March 23, 2015
1.7	Revised performance values	December 1, 2015
1.9	Updated mechanical specifications for Type D	March 23, 2017