

Halogen Free & RoHS Recast Compliant
Industrial CompactFlash Series 6

July 31, 2017

Revision 1.2

***This Specification Describes the Features and Capabilities of
the Industrial CompactFlash Cards***

***Please Contact Fortasa Sales for any Custom Features
Required For Your Specific Application***



1111 Triton Dr
Suite 100
Foster City, CA 94404 USA
888-367-8588
www.fortasa.com

Features:

- **CompactFlash Association Specification Revision 6.0 Standard Interface**
 - ATA command set compatible
 - ATA mode support for up to:
 - PIO Mode-6
 - Multiword DMA Mode-4
 - Ultra DMA Mode-7
 - PCMCIA UDMA Mode-7
- **Connector Type**
 - 50 pins female
- **Low power consumption (typical)**
 - Supply voltage: 3.3V & 5V
 - Active mode: 260 mA (@ 5V)
 - Sleep mode: 10 mA (@ 5V)
- **Performance**
 - Sustained read: up to 115 MB/sec
 - Sustained write: up to 75 MB/sec
- **Capacity**
 - 8, 16, 32, 64GB
- **NAND flash type: MLC**
- **Superior Reliability Through Built-in Hardware ECC**
 - Corrects up to 72 single-bit errors per 1,024-byte sector
- **Temperature ranges**
 - Operation:
 - Standard Temperature: 0°C to 70°C
 - Industrial Temperature: -40°C to 85°C
 - Storage: -40°C to 100°C
- **Flash management**
 - Intelligent endurance design
 - Advanced wear-leveling algorithms*
 - S.M.A.R.T. Technology*
 - Enhanced Data Integrity*
 - Intelligent power failure recovery
- **RoHS Recast Compliant**
 - Complies with 2011/65/EU

Table of Contents

1. General Description	4
2. Functional Block.....	4
3. Pin Assignments.....	5
4. Product Specifications	7
4.1 Capacity Specification.....	7
4.2 Performance Specification	7
4.3 Environmental Specifications.....	7
4.4 Certification & Compliance	8
5. Flash Management	9
5.1 Intelligent Flash Controller Features	9
5.1.1 Advanced wear-leveling algorithms.....	9
5.1.2 S.M.A.R.T. technology	9
5.1.3 Built-in hardware ECC.....	9
5.1.4 Enhanced data integrity	9
5.2 Intelligent Power Failure Recovery.....	9
6. Software Interface.....	10
6.1 Command Set.....	10
7. Electrical Specification.....	12
7.1 Power Consumption	12
8. Physical Characteristics	13
8.1 Dimensions.....	13
8.1.1 Without Write Protect Switch Dimensions.....	13
8.1.2 With Write Protect Switch Dimensions.....	14
9. Product Ordering Information.....	15
9.1 Product Code Designations	15
9.2 Valid Combinations.....	16
9.2.1 Without Write Protect	16
9.2.2 With Write Protect	18
10. Revision History	20

1. General Description

Fortasa's Industrial CompactFlash Card 6 (CF6) offers the highest reliability and performance storage solution critical to most demanding OEM customers.

Fortasa's CF6 provides complete PCMCIA - ATA functionality and compatibility. CF6 complies with CompactFlash specification revision 6.0, supporting transfer modes up to Programmed Input Output (PIO) Mode 6, Multiword Direct Memory Access (DMA) Mode 4, Ultra DMA Mode 7, and PCMCIA Ultra DMA Mode 7.

Fortasa's CompactFlash technology is designed for use in Point of Sale (POS) terminals, telecom, IP-STB, medical instruments, surveillance systems, industrial PCs and handheld applications. Featuring advanced technologies such as Advanced Wear-leveling algorithms, S.M.A.R.T, Enhanced Data Integrity, Built-in Hardware ECC, and Intelligent Power Failure Recovery, Fortasa's CompactFlash Card offers the most cost effective solution for most critical applications.

Manufactured using Industrial Temperature rated MLC NAND-flash, this SSD can work in highly demanding environment and withstand wide range of operating temperature from -40°C to +85°C.

Offered in standard and industrial temperature range, Fortasa's CompactFlash card 6 product is the most cost effective and trustworthy solution in the OEM memory system.

2. Functional Block

The CompactFlash Card (CF6) includes a controller and flash media, as well as the CompactFlash standard interface. Figure 2-1 shows the functional block diagram.

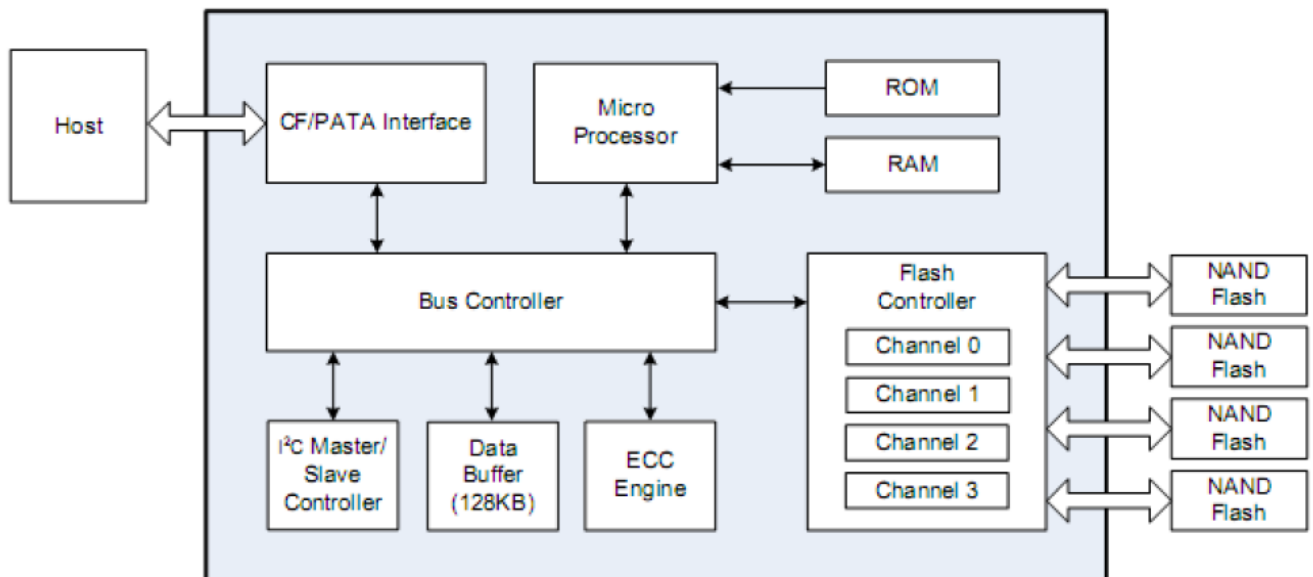

Figure 2-1: Functional Block Diagram

3. Pin Assignments

Table 3-1 lists the pin assignments with respective signal names for the 50-pin configuration. A “#” suffix indicates the active low signal. The pin type can be input, output or input/output.

Table 3-1: Pin assignments (1 of 2)

Pin No.	Memory card mode		I/O card mode		True IDE mode	
	Signal name	Pin I/O type	Signal name	Pin I/O type	Signal name	Pin I/O type
1	GND	-	GND	-	GND	-
2	D3	I/O	D3	I/O	D3	I/O
3	D4	I/O	D4	I/O	D4	I/O
4	D5	I/O	D5	I/O	D5	I/O
5	D6	I/O	D6	I/O	D6	I/O
6	D7	I/O	D7	I/O	D7	I/O
7	#CE1	I	#CE1	I	#CS0	I
8	A10	I	A10	I	A10 ¹	I
9	#OE	I	#OE	I	#ATA SEL	I
10	A9	I	A9	I	A9 ¹	I
11	A8	I	A8	I	A8 ¹	I
12	A7	I	A7	I	A7 ¹	I
13	VCC	-	VCC	-	VCC	-
14	A6	I	A6	I	A6 ¹	I
15	A5	I	A5	I	A5 ¹	I
16	A4	I	A4	I	A4 ¹	I
17	A3	I	A3	I	A3 ¹	I
18	A2	I	A2	I	A2	I
19	A1	I	A1	I	A1	I
20	A0	I	A0	I	A0	I
21	D0	I/O	D0	I/O	D0	I/O
22	D1	I/O	D1	I/O	D1	I/O
23	D2	I/O	D2	I/O	D2	I/O
24	WP	O	#IOIS16	O	#IOCS16	O
25	#CD2	O	#CD2	O	#CD2	O
26	#CD1	O	#CD1	O	#CD1	O
27	D11	I/O	D11	I/O	D11	I/O
28	D12	I/O	D12	I/O	D12	I/O
29	D13	I/O	D13	I/O	D13	I/O
30	D14	I/O	D14	I/O	D14	I/O
31	D15	I/O	D15	I/O	D15	I/O
32	#CE2	I	#CE2	I	#CS1	I
33	#VS1	O	#VS1	O	#VS1	O
34	#IORD	I	#IORD	I	#IORD	I
35	#IOWR	I	#IOWR	I	#IOWR	I
36	#WE	I	#WE	I	#WE	I
37	RDY#BSY	O	#IREQ	O	INTRQ	O
38	VCC	-	VCC	-	VCC	-
39	#CSEL	I	#CSEL	I	#CSEL	I
40	#VS2	O	#VS2	O	#VS2	O
41	RESET	I	RESET	I	#RESET	I

Table 3-1: Pin assignments (2 of 2)

Pin No.	Memory card mode		I/O card mode		True IDE mode	
	Signal name	Pin I/O type	Signal name	Pin I/O type	Signal name	Pin I/O type
42	#WAIT	O	#WAIT	O	IORDY	O
43	#INPACK	O	#INPACK	O	DMARQ ²	O
44	#REG	I	#REG	I	DMACK ²	I
45	BVD2	O	#SPKR	O	#DASP	I/O
46	BVD1	O	#STCHG	O	#PDIAG	I/O
47	D8	I/O	D8	I/O	D8	I/O
48	D9	I/O	D9	I/O	D9	I/O
49	D10	I/O	D10	I/O	D10	I/O
50	GND	-	GND	-	GND	-

1. The signal should be grounded by the host.
2. Connection required when UDMA is in use.

4. Product Specifications

4.1 Capacity Specification

Standard capacity specification of the CompactFlash Card products are shown in Table 4-1. The table lists the specific capacity and the default numbers of heads, sectors and cylinders (CHS) for each product line.

Table 4-1: Capacity specifications

Capacity	Total Bytes ^{1,2}	Cylinders	Heads	Sectors	Max LBA
8GB	8,195,604,480	15,880	16	63	16,007,040
16GB	16,391,340,032	16383 ³	16	63	32,014,336
32GB	32,019,316,736	16383 ³	16	63	62,537,728
64GB	64,030,244,864	16383 ³	16	63	125,059,072

1. Total bytes includes reserved system blocks.
2. Total bytes displayed varies depending on the operating system.
3. Cylinders, heads or sectors are not applicable for these capacities. Only LBA addressing applies.

***Notes: 1 GB = 1,000,000,000 bytes; 1 sector = 512 bytes.

LBA count addressed in the table above indicates total user storage capacity and will remain the same throughout the lifespan of the device. However, the total usable capacity of the CF card is most likely to be less than the total physical capacity because a small portion of the capacity is reserved for device maintenance usages.

Please contact Fortasa Memory System Sales for any non-listed CompactFlash Card capacity or custom CHS requirement.

4.2 Performance Specification

Performances of the various capacities of the CompactFlash card are listed in Table 4-2.

Table 4-2: Standard Performance specifications

Capacity	8GB	16GB	32GB	64GB
Performance				
Sustained read (MB/s)	80	115	115	115
Sustained write (MB/s)	27	47	44	75

4.3 Environmental Specifications

Environmental specification of the CompactFlash Card series follows the MIL-STD-810F standard as shown in Table 4-3.

Table 4-3: Environmental specifications

Environment		Specification
Temperature	Operation	0°C to 70°C (Standard) / -40°C to 85°C (Industrial)
	Storage	-40°C to 100°C
Vibration		Sine wave: 10~2000Hz, 15G (X, Y, Z axes)
Shock		Half sine wave, Peak acceleration 50 G (X, Y, Z ; All 6 axes)
Humidity		5% to 95% RH (Non-condensing)

4.4 Certification & Compliance

The CompactFlash card complies with the following global standards:

- CE
- FCC
- Halogen-free
- EMC
- RoHS Recast (2011/65/EU)

5. Flash Management

The most critical attribute of a Fortasa CompactFlash Card is its inherent high level of reliability. This characteristic is achieved through unique technical features of Flash Controller and specific component selection that offer higher degree of reliability compared to the consumer grade components.

5.1 Intelligent Flash Controller Features

5.1.1 Advanced wear-leveling algorithms

All NAND flash devices are limited by a finite number of write cycles. Under a standard file system, frequent file table updates are mandatory. As a painful side effect of OS file overhead, some areas of flash address space wear out faster than others. As these certain sections get a substantially higher write occurrence the whole CompactFlash card can wear out very quickly. This uneven wear would significantly reduce the lifetime of the whole device, even if majority of the Flash sectors are far from the write cycle limit. Fortasa's CompactFlash Card products offer advanced data wear leveling which distributes Flash writes evenly across the card memory space. By utilizing this advanced wear leveling feature, the lifetime of the media can be significantly extended.

5.1.2 S.M.A.R.T. technology

S.M.A.R.T. is an acronym for Self-Monitoring, Analysis and Reporting Technology, an open standard allowing disk drives to automatically monitor their own health and report potential problems. It protects the user from unscheduled downtime by monitoring and storing critical drive performance and calibration parameters. Ideally, this should allow taking proactive actions to prevent impending drive failure. Fortasa SMART feature adopts the conventional SMART command B0h to read data from the drive. By having the Fortasa SMART Utility running on the host, the system can monitor and analyze the CompactFlash card status and determine the end of useful life for a graceful and scheduled maintenance and replacement.

5.1.3 Built-in hardware ECC

The Fortasa Flash Controller uses superior BCH Error Detection Code (EDC) and Error Correction Code (ECC) algorithms capable of correcting up to 72 random bits in 1Kbytes data. This built-in hardware ECC performs parity generation and error detection/correction for data integrity.

5.1.4 Enhanced data integrity

The properties of NAND flash memory make it ideal for applications that require high integrity while operating in challenging environments. The integrity of data to NAND flash memory is generally maintained through ECC algorithms and bad block management. Flash controllers can support up to 8 bits ECC capability for accuracy of data transactions, and bad block management is a preventive mechanism from loss of data by retiring unusable media blocks and relocating the data to the other blocks, along with the integration of advanced wear leveling algorithms, so that the lifespan of device can be expanded.

5.2 Intelligent Power Failure Recovery

The Low Power Detection on the Flash controller initiates cached data saving before the power supply to the device drops too low for operation. This feature prevents the device from system crash and ensures data integrity during an unexpected brownout. This feature makes sure that there are no catastrophic failures of the CompactFlash card due to system power glitches.

6. Software Interface

6.1 Command Set

Table 6-1 summarizes the command set with the paragraphs that follow describing the individual commands and the task file for each.

Table 6-1: Command set

Command	Code	Protocol
Check-Power-Mode	E5H or 98H	Non-Data
Execute-Drive-Diagnostic	90H	Device Diagnostic
Erase-Sector(s)	C0H	Non-Data
Flush-Cache	E7H	Non-Data
Flush-Cache Ext	EAH	Non-Data
Format-Track	50H	PIO Data-Out
Identify-Drive	ECH	PIO Data-In
Idle	E3H or 97H	Non-Data
Idle-Immediate	E1H or 95H	Non-Data
Initialize-Drive-Parameters	91H	Non-Data
NOP	00H	Non-Data
Read-Buffer	E4H	PIO Data-In
Read DMA	C8H or C9H	DMA
Read DMA Ext	25H	DMA
Read Native Max Address	F8H	Non-Data
Read-Multiple	C4H	PIO Data-In
Read-Multiple Ext	29H	PIO Data-In
Read-Sector(s)	20H or 21H	PIO Data-In
Read-Sector(s) Ext	24H	PIO Data-In
Read-Verify-Sector(s)	40H or 41H	Non-Data
Read-Verify-Sector(s) Ext	42H	Non-Data
Recalibrate	1XH	Non-Data
Request-Sense	03H	Non-Data
Seek	7XH	Non-Data
Security Set Password	F1H	PIO Data-Out
Security Unlock	F2H	PIO Data-Out
Security Erase Prepare	F3H	Non-Data
Security Erase Unit	F4H	PIO Data-Out
Security Freeze Lock	F5H	Non-Data
Security Disable Password	F6H	PIO Data-Out
Set-Features	EFH	Non-Data
Set-Multiple-Mode	C6H	Non-Data
Set Max	F9H	Non-Data/PIO Data-Out
Set-Sleep-Mode	E6H or 99H	Non-Data
SMART	B0H	Non-Data

Stand-By	E2H or 96H	Non-Data
Stand-By-Immediate	E0H or 94H	Non-Data
Translate Sector	87H	PIO Data-In
Wear Level	F5H	Non-Data
Write-Buffer	E8H	PIO Data-Out
Write DMA	CAH or CBH	DMA
Write DMA Ext	35H	DMA
Write-Multiple	C5H	PIO Data-Out
Write-Multiple FUA Ext	CEH	PIO Data-Out
Write-Multiple-Without-Erase	CDH	PIO Data-Out
Write-Sector(s)	30H or 31H	PIO Data-Out
Write-Sector(s) Ext	34H	PIO Data-Out
Write-Sector(s)-Without-Erase	38H	PIO Data-Out
Write-Verify	3CH	PIO Data-Out

7. Electrical Specification

Caution: Absolute Maximum Stress Ratings – Applied conditions greater than those listed under “Absolute Maximum Stress Ratings” may cause permanent damage to the device. This is a stress rating only and functional operation of the device at these conditions or conditions greater than those defined in the operational sections of this data sheet is not implied. Exposure to absolute maximum stress rating conditions may affect device reliability.

Table 7-1: Operating range

Range	Ambient Temperature	3.3V	5V
Standard	0°C to +70°C	3.135-3.465V	4.75-5.25V
Industrial	-40°C to +85°C		

7.1 Power Consumption

Table 7-2 lists the CompactFlash Card 6 power consumption.

Table 7-2 CompactFlash 6 power consumption @ 3.3V (typical)

Performance \ Capacity	8 GB	16GB	32GB	64GB
	Active Mode (mA)	195	250	245
Idle Mode (mA)	10	10	10	10

Table 7-3 CompactFlash 6 power consumption @ 5V (typical)

Performance \ Capacity	8 GB	16GB	32GB	64GB
	Active Mode (mA)	200	260	255
Idle Mode (mA)	10	10	10	10

Note: Power consumptions were measured at 5V power supply and may vary depending on settings and platforms

8. Physical Characteristics

8.1 Dimensions

TABLE 8-1: Type I CF6 physical specification

Length:	36.40 +/- 0.15mm (1.433+/- 0.06 in.)
Width:	42.80 +/- 0.10mm (1.685+/- 0.04 in.)
Thickness (Including Label Area):	3.3mm+/-0.10mm (0.130+/-0.04in.)

8.1.1 Without Write Protect Switch Dimensions

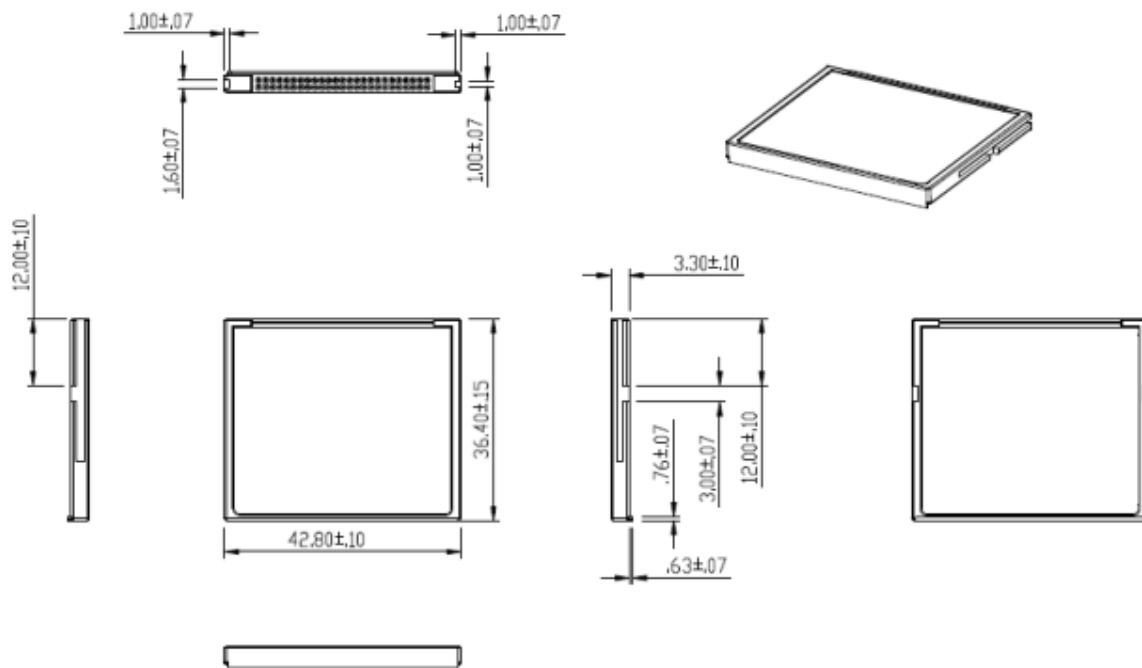
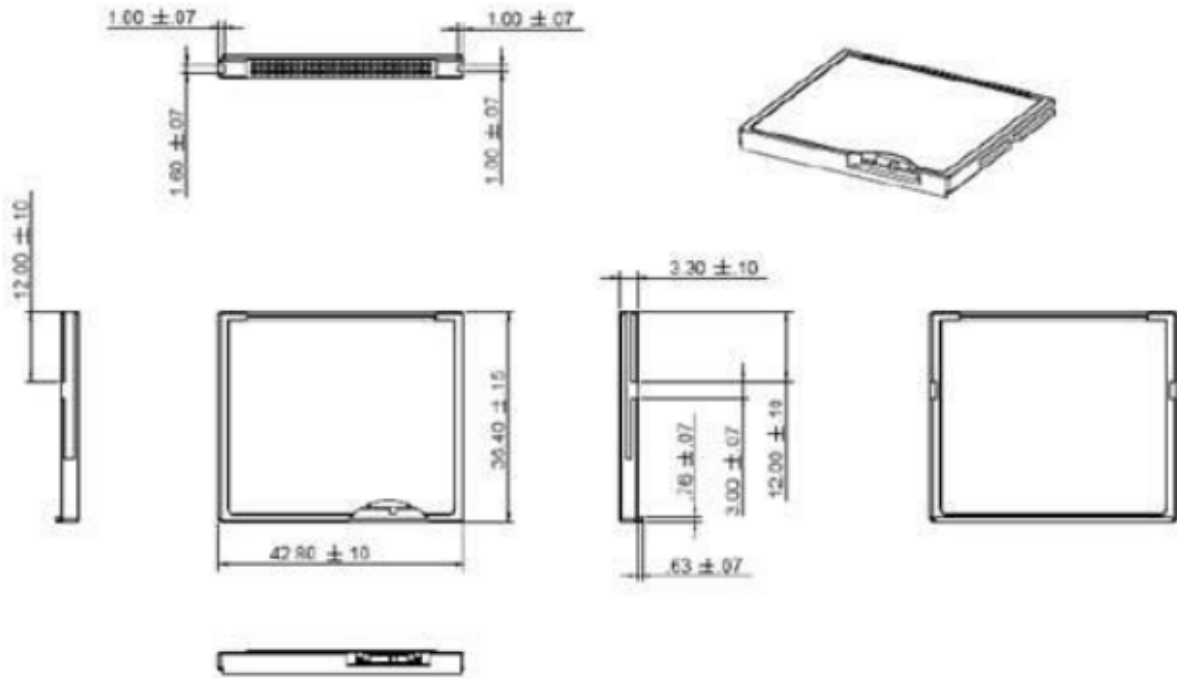

FIGURE 8-1: Physical dimension

CompactFlash Card 6 FMS-CFxxxxXBNS-XXXXX



8.1.2 With Write Protect Switch Dimensions



9. Product Ordering Information

9.1 Product Code Designations

FMS – C F x x x x x B N S – XXXXX

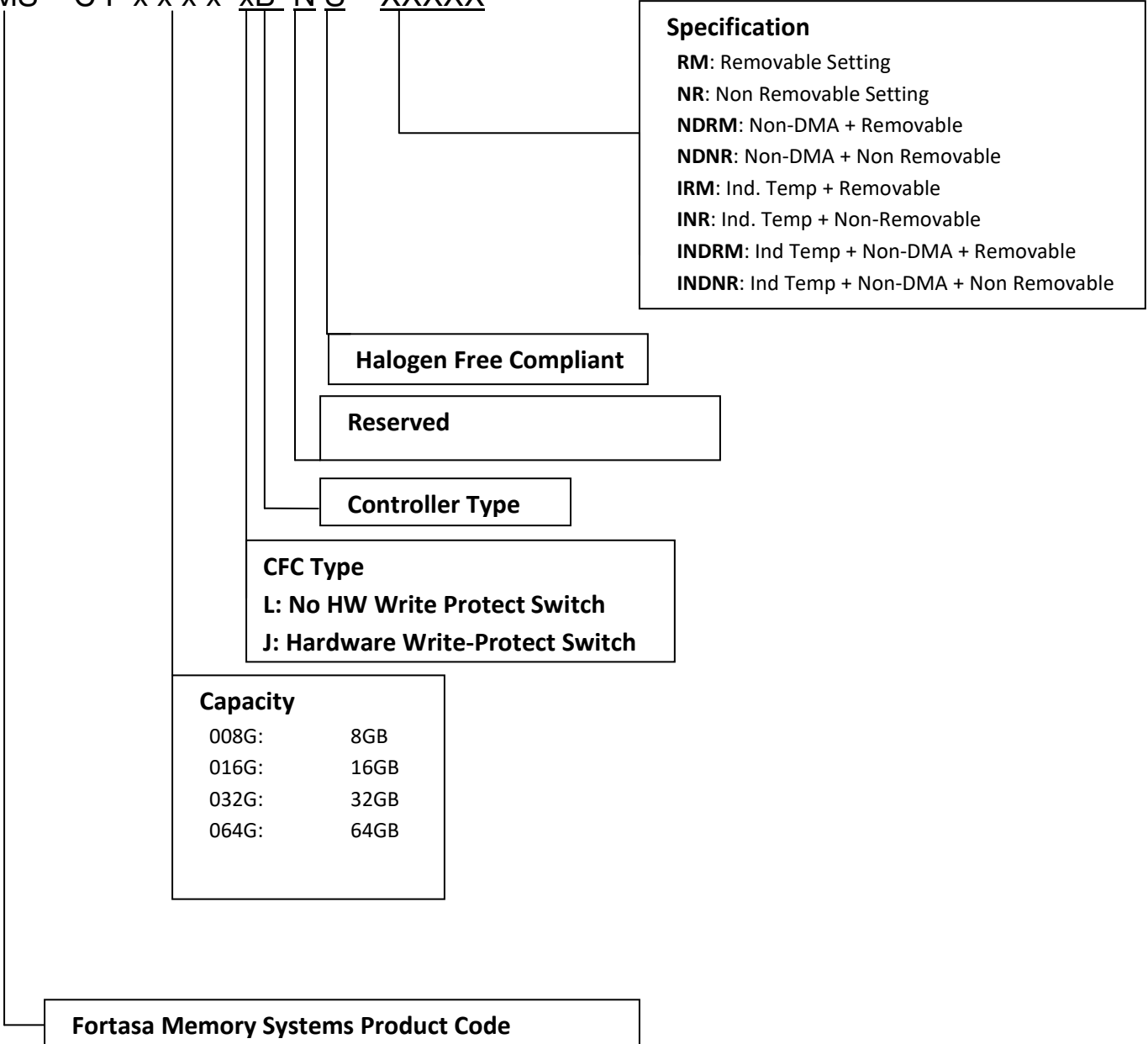

9.2 Valid Combinations

9.2.1 Without Write Protect

9.2.1.1 Standard Temperature

Removable Configuration

Standard Speed	
Capacity	Model Number
8GB	FMS-CF008GLBNS-RM
16GB	FMS-CF016GLBNS-RM
32GB	FMS-CF032GLBNS-RM
64GB	FMS-CF0642GLBNS-RM

Non-Removable Configuration

Standard Speed	
Capacity	Model Number
8GB	FMS-CF008GLBNS-NR
16GB	FMS-CF016GLBNS-NR
32GB	FMS-CF032GLBNS-NR
64GB	FMS-CF064GLBNS-NR

Non-DMA and Removable Configuration

Standard Speed	
Capacity	Model Number
8GB	FMS-CF008GLBNS-NDRM
16GB	FMS-CF016GLBNS-NDRM
32GB	FMS-CF032GLBNS-NDRM
64GB	FMS-CF064GLBNS-NDRM

Non-DMA and Non-Removable Configuration

Standard Speed	
Capacity	Model Number
8GB	FMS-CF008GLBNS-NDNR
16GB	FMS-CF016GLBNS-NDNR
32GB	FMS-CF032GLBNS-NDNR
64GB	FMS-CF064GLBNS-NDNR

9.2.1.2 Industrial Temperature

Removable Configuration

Standard Speed	
Capacity	Model Number
8GB	FMS-CF008GLBNS-IRM
16GB	FMS-CF016GLBNS-IRM
32GB	FMS-CF032GLBNS-IRM
64GB	FMS-CF064GLBNS-IRM

Non-Removable Configuration

Standard Speed	
Capacity	Model Number
8GB	FMS-CF008GLBNS-INR
16GB	FMS-CF016GLBNS-INR
32GB	FMS-CF032GLBNS-INR
64GB	FMS-CF064GLBNS-INR

Non-DMA and Removable Configuration

Standard Speed	
Capacity	Model Number
8GB	FMS-CF008GLBNS-INDRM
16GB	FMS-CF016GLBNS-INDRM
32GB	FMS-CF032GLBNS-INDRM
64GB	FMS-CF064GLBNS-INDRM

Non-DMA and Non-Removable Configuration

Standard Speed	
Capacity	Model Number
8GB	FMS-CF008GLBNS-INDNR
16GB	FMS-CF016GLBNS-INDNR
32GB	FMS-CF032GLBNS-INDNR
64GB	FMS-CF064GLBNS-INDNR

9.2.2 With Write Protect

9.2.2.1 Standard Temperature

Removable Configuration

Standard Speed	
Capacity	Model Number
8GB	FMS-CF008GJBNS-RM
16GB	FMS-CF016GJBNS-RM
32GB	FMS-CF032GJBNS-RM
64GB	FMS-CF064GJBNS-RM

Non-Removable Configuration

Standard Speed	
Capacity	Model Number
8GB	FMS-CF008GJBNS-NR
16GB	FMS-CF016GJBNS-NR
32GB	FMS-CF032GJBNS-NR
64GB	FMS-CF064GJBNS-NR

Non-DMA and Removable Configuration

Standard Speed	
Capacity	Model Number
8GB	FMS-CF008GJBNS-NDRM
16GB	FMS-CF016GJBNS-NDRM
32GB	FMS-CF032GJBNS-NDRM
64GB	FMS-CF064GJBNS-NDRM

Non-DMA and Non-Removable Configuration

Standard Speed	
Capacity	Model Number
8GB	FMS-CF008GJBNS-NDNR
16GB	FMS-CF016GJBNS-NDNR
32GB	FMS-CF032GJBNS-NDNR
64GB	FMS-CF064GJBNS-NDNR

9.2.2.2 Industrial Temperature

Removable Configuration

Standard Speed	
Capacity	Model Number
8GB	FMS-CF008GJBNS-IRM
16GB	FMS-CF016GJBNS-IRM
32GB	FMS-CF032GJBNS-IRM
64GB	FMS-CF064GJBNS-IRM

Non-Removable Configuration

Standard Speed	
Capacity	Model Number
8GB	FMS-CF008GJBNS-INR
16GB	FMS-CF016GJBNS-INR
32GB	FMS-CF032GJBNS-INR
64GB	FMS-CF064GJBNS-INR

Non-DMA and Removable Configuration

Standard Speed	
Capacity	Model Number
8GB	FMS-CF008GJBNS-INDRM
16GB	FMS-CF016GJBNS-INDRM
32GB	FMS-CF032GJBNS-INDRM
64GB	FMS-CF064GJBNS-INDRM

Non-DMA and Non-Removable Configuration

Standard Speed	
Capacity	Model Number
8GB	FMS-CF008GJBNS-INDNR
16GB	FMS-CF016GJBNS-INDNR
32GB	FMS-CF032GJBNS-INDNR
64GB	FMS-CF064GJBNS-INDNR

10. Revision History

Revision	Date	Description	Comments
1.0	1/26/2017	Initial Release	
1.1	3/14/2017	Updated Performance Specification	
1.2	7/31/2017	Added 64GB support	