

RoHS Compliant
ATA Flash Drive Series

Datasheet for Standard AFD 187

September 4th, 2012

Revision 1.0



***This Specification Describes the Features and Capabilities of
the Standard and Industrial Temperature
ATA Flash Drives***

***Please Contact Fortasa Memory Systems Sales for any
Custom Features Required For Your Specific Application***



4151 Middlefield Road
2nd Floor
Palo Alto, CA 94303 USA
888-367-8588
www.fortasa.com

Features:

- **Standard ATA/IDE Bus Interface**
 - ATA command set compatible
 - ATA operating mode support for up to:
 - PIO Mode-4
 - Multiword DMA Mode-2
 - Ultra DMA Mode-6
- **Connector Type**
 - 40-pin ZIF
- **Low power consumption (typical)**
 - Supply voltage: 3.3V
 - Active mode: 375 mA
 - Sleep mode: 30 mA
- **Performance**
 - Sustained read: up to 100 MB/sec
 - Sustained write: up to 95 MB/sec
- **Capacity**
 - Standard:
 - <4GB – Contact Factory
 - 4, 8, 16, 32, 64, 128 GB
- **NAND flash type: SLC**
- **Superior Reliability Through Built-in Hardware ECC**
 - Corrects up to 72 random single-bit errors per 1Kbyte sector
- **Temperature ranges**
 - Operation:
 - Standard Temperature: 0 °C to 70 °C
 - Industrial Temperature: -40 °C to 85 °C
 - Storage: -40 °C to 100 °C
- **Flash management**
 - Intelligent endurance design
 - Advanced wear-leveling algorithms*
 - S.M.A.R.T. Technology*
 - Enhanced Data Integrity*
 - Intelligent power failure recovery
 - Enhanced security level
 - Secure erase*
- **RoHS compliant**



Table of Contents

1. General Description	4
2. Functional Block.....	4
3. Pin Assignments.....	5
4. Capacity Specification	6
4.1 Performance Specification	6
4.2 Environmental Specifications.....	7
5. Flash Management	7
5.1 Intelligent Flash Controller Features	7
5.1.1 Advanced wear-leveling algorithms.....	7
5.1.2 S.M.A.R.T. technology	7
5.1.3 Built-in hardware ECC.....	7
5.1.4 Enhanced data integrity	8
5.2 Intelligent Power Failure Recovery.....	8
5.3 Enhanced Security Level – Special Features.....	8
6. Software Interface	9
6.1 Command Set.....	9
7. Electrical Specification	10
7.1 Operating Voltage	10
7.2 Power Consumption	10
8. Physical Characteristics	11
8.1 Dimensions.....	11
9. Product Ordering Information.....	12
9.1 Product Code Designations	12
9.2 Valid Combinations.....	13
10. Revision History	14

1. General Description

Fortasa’s ATA-Flash Drive (AFD) is a high-performance, solid state drive (SSD) designed to replace a conventional IDE hard disk drive. AFD supports standard ATA/IDE protocol and can be plugged into a standard IDE connector commonly found in portable PCs. Solid State Drive is an order of magnitude more rugged, reliable and power-efficient compared to the mechanical hard drive. It’s especially applicable for use in rugged laptops, military devices, thin clients, Point of Sale (POS) terminals, telecom, medical instruments, surveillance systems and industrial PCs. Fortasa AFD Series is the best drop-in replacement for high-maintenance HDD where reliability is of a major importance.

ATA Flash Drive includes a built-in microcontroller and file management firmware that communicates through with the ATA standard interfaces and is set to the Master operation in default. This means the AFD does not require any additional or proprietary host software such as the Flash File System (FFS) and Memory Technology Driver (MTD) software. AFD is designed to work at 3.3 Volts, support the standard ATA/IDE protocol up to PIO Mode-4, Multiword DMA Mode-2, and Ultra DMA Mode-6 interfaces and uses a standard ATA driver that fits to all major operating systems such as Microsoft’s Windows series, MAC OS, and UNIX variants.

Featuring technologies as Advanced Wear-leveling algorithms, S.M.A.R.T, Built-In Hardware ECC, Enhanced Data Integrity, Intelligent Power Failure Recovery, Secure Protection Zone and Quick Erase, Fortasa’s AFD assures users of a versatile device on data storage.

2. Functional Block

The ATA Flash Drive includes a controller and flash media, as well as the ATA standard interface. Figure 2-1 shows the functional block diagram.

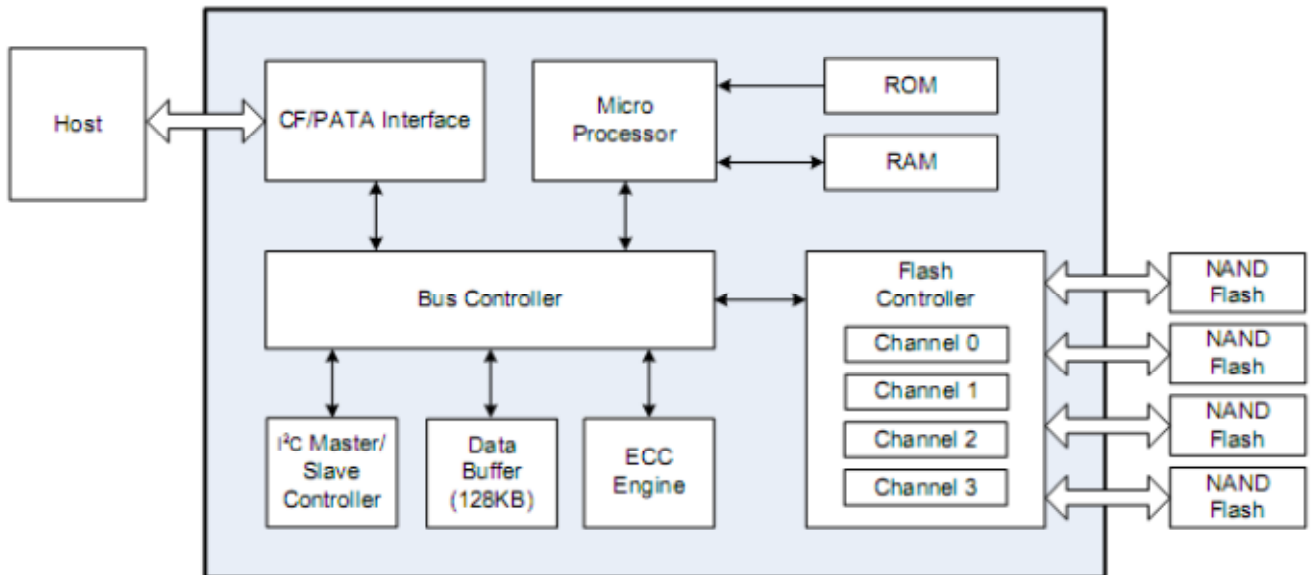

Figure 2-1: Functional block diagram

3. Pin Assignments

Table 3-1 lists the pin assignments with respective signal names for the 40-pin configuration. A “#” suffix indicates the active low signal. The pin type can be input, output or input/output.

Figure 3-1: ATA-Flash Drive 40-pin Connector

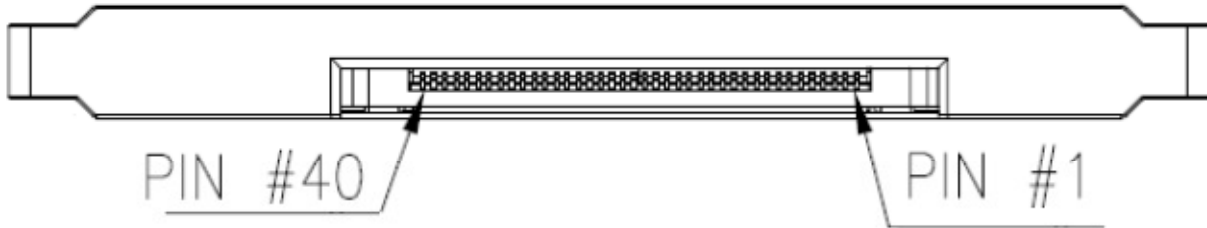

Table 3-1: Pin assignments for the 40-pin configuration

Pin No	Signal Name	Pin No	Signal Name
1	Reserved	21	GND
2	Reserved	22	DMARQ
3	RESET#	23	GND
4	GND	23	IOWR# STOP
5	D7	25	IORD# HDMARDY# HSTROBE
6	D8	26	GND
7	D6	27	IORDY DDMARDY# DSTROBE
8	D9	28	GND
9	D5	29	DMACK#
10	D10	30	INTRQ
11	D4	31	A1
12	D11	32	PDIAG#
13	D3	33	A0
14	D12	34	A2
15	D2	35	CS1FX#
16	D13	36	CS3FX#
17	D1	37	DASP#
18	D14	38	VDD
19	D0	39	VDD
20	D15	40	CSEL

4. Capacity Specification

Standard capacity specification of the ATA Flash Drive product are shown in Table 4-1. The table lists the specific capacity and the default numbers of heads, sectors and cylinders (CHS) for each product line.

Table 4-1: Capacity specifications

Capacity	Total Bytes	Cylinders	Heads	Sectors	Max LBA
<4GB	Contact Fortasa Memory Systems Sales				
4GB	4,011,614,208	7773	16	63	7,835,184
8GB	8,012,390,400	15525	16	63	15,649,200
16GB	16,013,942,784	16383 ¹	16	63	31,277,232
32GB	32,017,047,552	16383 ¹	16	63	62,533,296
64GB	64,023,187,088	16383 ¹	16	63	125,045,424
128GB	128,035,676,160	16383 ¹	16	63	250,069,680

1. Cylinders, heads or sectors are not applicable for these capacities. Only LBA addressing applies.

Please contact factory for any non-listed ATA Flash Drive capacity or custom CHS requirement.

4.1 Performance Specification

Performances of the ATA Flash Drive are listed in Table 4-2.

Table 4-2: Standard Performance specifications

Capacity \ Performance	4GB	8GB	16GB	32GB	64GB	128GB
Sustained read (MB/s)	100	100	100	100	100	100
Sustained write (MB/s)	45	85	90	95	95	95

4.2 Environmental Specifications

Environmental specification of the ATA Flash Drive series follows the MIL-STD-810F standard as shown in Table 4-3.

Table 4-3: Environmental specifications

Environment		Specification
Temperature	Operation	0°C to 70°C (standard); -40°C to 85°C (Industrial temperature)
	Storage	-40°C to 100°C
Vibration		Sine wave: 10~2000Hz, 15G (X, Y, Z axes)
Shock		Half sine wave, Peak acceleration 50 G, 11 ms (X, Y, Z ; All 6 axes)
Humidity		5% to 95% RH (Non-condensing)

5. Flash Management

The most critical attribute of an Industrial grade ATA Flash Drive is its inherent high level of reliability. This characteristic is achieved through unique technical features of Flash Controller and specific component selection that offer higher degree of reliability compared to the consumer grade components.

5.1 Intelligent Flash Controller Features

5.1.1 Advanced wear-leveling algorithms

All NAND flash devices are limited by a finite number of write cycles. Under a standard file system, frequent file table updates are mandatory. As a painful side effect of OS file overhead, some areas of flash address space wear out faster than others. As these certain sections get a substantially higher write occurrence the whole ATA Flash Drive can wear out very quickly. This uneven wear would significantly reduce the lifetime of the whole device, even if majority of the Flash sectors are far from the write cycle limit. Fortasa’s ATA Flash Drive products offer advanced data wear leveling which distributes Flash writes evenly across the ATA Flash Drive memory space. By utilizing this advanced wear leveling feature, the lifetime of the media can be significantly extended.

5.1.2 S.M.A.R.T. technology

S.M.A.R.T. is an acronym for Self-Monitoring, Analysis and Reporting Technology, an open standard allowing disk drives to automatically monitor their own health and report potential problems. It protects the user from unscheduled downtime by monitoring and storing critical drive performance and calibration parameters. Ideally, this should allow taking proactive actions to prevent impending drive failure. Fortasa SMART feature adopts the conventional SMART command B0h to read data from the drive. By having the Fortasa SMART Utility running on the host, the system can monitor and analyze the ATA Flash Drive status and determine the end of useful life for a graceful and scheduled maintenance and replacement.

5.1.3 Built-in hardware ECC

The Fortasa Flash Controller uses superior BCH Error Detection Code (EDC) and Error Correction Code (ECC) algorithms which correct up to 72 random single-bit errors for each 1Kbyte block of data. High performance is fulfilled through hardware-based error detection and correction.

5.1.4 Enhanced data integrity

The properties of NAND flash memory make it ideal for applications that require high integrity while operating in challenging environments. The integrity of data to NAND flash memory is generally maintained through ECC algorithms and bad block management. Flash controllers can support up to 72 bits ECC capability for accuracy of data transactions, and bad block management is a preventive mechanism from loss of data by retiring unusable media blocks and relocating the data to the other blocks, along with the integration of advanced wear leveling algorithms, so that the lifespan of device can be expanded.

5.2 Intelligent Power Failure Recovery

The Low Power Detection on the Flash controller initiates cached data saving before the power supply to the device drops too low for operation. This feature prevents the device from system crash and ensures data integrity during an unexpected brownout. This feature makes sure that there are no catastrophic failures of the ATA Flash Drive due to system power glitches.

5.3 Enhanced Security Level – Special Features

Fortasa's ATA Flash Drive products offer additional security features that are not standard to the ATA interface.

5.3.1 Secure erase

Accomplished by the Secure Erase (SE) command is part of the open ANSI standards that control disk drives. "ATA Secure Erase" is built into the disk drive firmware and thus far less susceptible to malicious software attacks than external software utilities. Executing this command causes a drive to internally completely erase all possible user data. Once executed, neither data nor the erase counter on the device would be recoverable, which skews the accuracy of the device lifespan monitor. The erase process can't be stopped until finished even while encountering power failure, and will continue once the power is back on.

Please contact Fortasa Memory Systems Sales for more information about these unique features.

6. Software Interface

6.1 Command Set

Table 6-1 summarizes the command set with the paragraphs that follow describing the individual commands and the task file for each.

Table 6-1: Command set

Command	Code	FR ¹	SC ²	SN ³	CY ⁴	DH ⁵	LBA ⁶
Check-Power-Mode	E5H or 98H	-	-	-	-	D8	-
Execute-Drive-Diagnostic	90H	-	-	-	-	D	-
Erase-Sector(s)	C0H	-	Y	Y	Y	Y	Y
Flush-Cache	E7H	-	-	-	-	D	-
Format-Track	50H	-	Y ⁷	-	Y	Y ⁸	Y
Identify-Drive	ECH	-	-	-	-	D	-
Idle	E3H or 97H	-	Y	-	-	D	-
Idle-Immediate	E1H or 95H	-	-	-	-	D	-
Initialize-Drive-Parameters	91H	-	Y	-	-	Y	-
NOP	00H	-	-	-	-	D	-
Read-Buffer	E4H	-	-	-	-	D	-
Read DMA	C8H or C9H	-	Y	Y	Y	Y	Y
Read-Multiple	C4H	-	Y	Y	Y	Y	Y
Read-Sector(s)	20H or 21H	-	Y	Y	Y	Y	Y
Read-Verify-Sector(s)	40H or 41H	-	Y	Y	Y	Y	Y
Recalibrate	1XH	-	-	-	-	D	-
Request-Sense	03H	-	-	-	-	D	-
Security-Disable-Password	F6H	-	-	-	-	D	-
Security-Erase-Prepare	F3H	-	-	-	-	D	-
Security-Erase-Unit	F4H	-	-	-	-	D	-
Security-Freeze-Lock	F5H	-	-	-	-	D	-
Security-Set-Password	F1H	-	-	-	-	D	-
Security-Unlock	F2H	-	-	-	-	D	-
Seek	7XH	-	-	Y	Y	Y	Y
Set-Features	EFH	Y	-	-	-	D	-
SMART	B0H	Y	Y	Y	Y	D	-
Set-Multiple-Mode	C6H	-	Y	-	-	D	-
Set-Sleep-Mode	E6H or 99H	-	-	-	-	D	-
Stand-By	E2H or 96H	-	-	-	-	D	-
Stand-By-Immediate	E0H or 94H	-	-	-	-	D	-
Translate Sector	87H	-	Y	Y	Y	Y	Y
Write-Buffer	E8H	-	-	-	-	D	-
Write DMA	CAH or CBH	-	Y	Y	Y	Y	Y
Write-Multiple	C5H	-	Y	Y	Y	Y	Y
Write-Multiple-Without-Erase	CDH	-	Y	Y	Y	Y	Y
Write-Sector(s)	30H or 31H	-	Y	Y	Y	Y	Y
Write-Sector(s)-Without-Erase	38H	-	Y	Y	Y	Y	Y
Write-Verify	3CH	-	Y	Y	Y	Y	Y

1. FR - Features register

2. SC - Sector Count register

3. SN - Sector Number register

ATA Flash Drive – 1.8”

FMS-FD18C22BxxxxS-XXXX



- 4. CY - Cylinder registers
- 5. DH - Drive/Head register
- 6. LBA - Logical Block Address mode supported (see command descriptions for use)
- 7. Y - The register contains a valid parameter for this command
- 8. For the Drive/Head register:
 - Y means both the CFC and Head parameters are used
 - D means only the CFC parameter is valid and not the Head parameter

7. Electrical Specification

7.1 Operating Voltage

Caution: Absolute Maximum Stress Ratings – Applied conditions greater than those listed under “Absolute Maximum Stress Ratings” may cause permanent damage to the device. This is a stress rating only and functional operation of the device at these conditions or conditions greater than those defined in the operational sections of this data sheet is not implied. Exposure to absolute maximum stress rating conditions may affect device reliability.

Table 7-1: Operating range

Range	Ambient Temperature	5V
Commercial	0°C to +70°C	3.135 ~ 3.465V
Industrial	-40°C to +85°C	

7.2 Power Consumption

Table 7-2 lists the AFD 187 power consumption.

Table 7-2 AFD 187 power consumption (typical)

Performance \ Capacity	4GB	8GB	16GB	32GB	64GB	128GB
	Active Mode (mA)	250	265	335	375	305
Idle Mode (mA)	15	15	15	17	30	30

8. Physical Characteristics

8.1 Dimensions

FIGURE 8-1: Physical dimensions

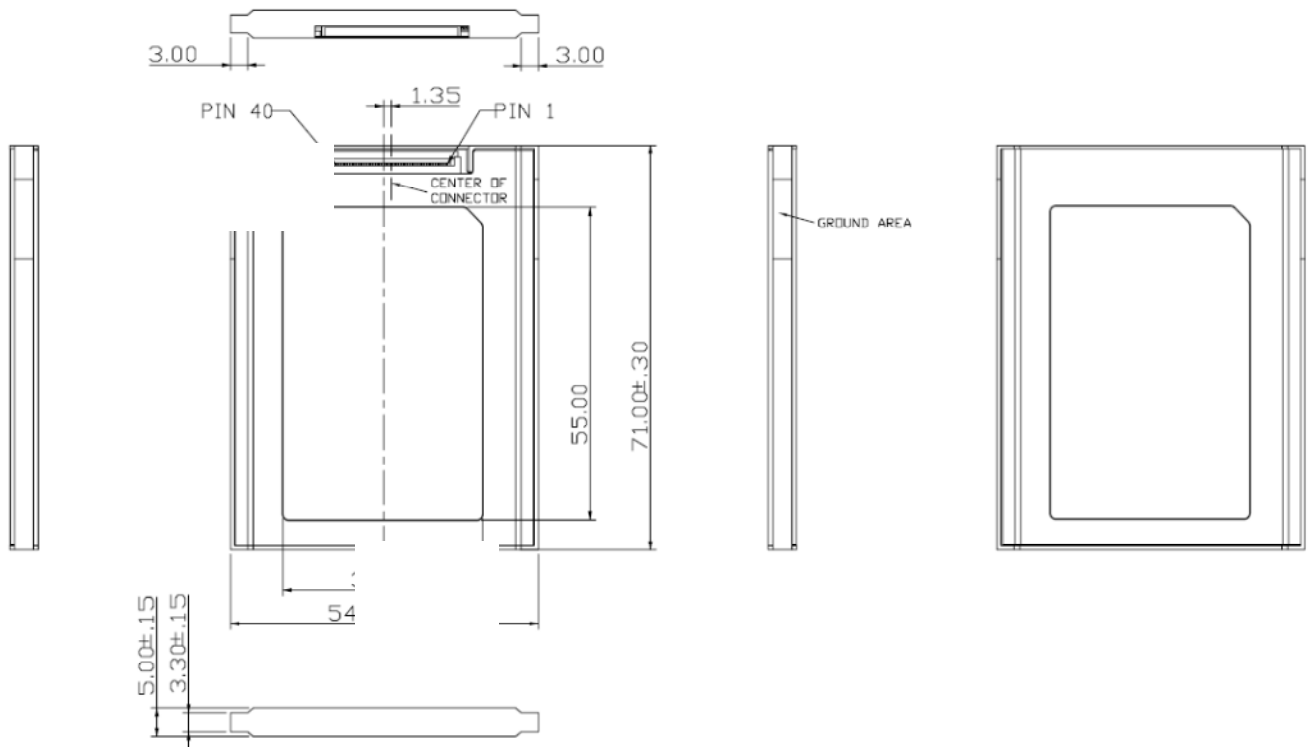

Unit: mm
Tolerance: ± 0.2

9. Product Ordering Information

9.1 Product Code Designations

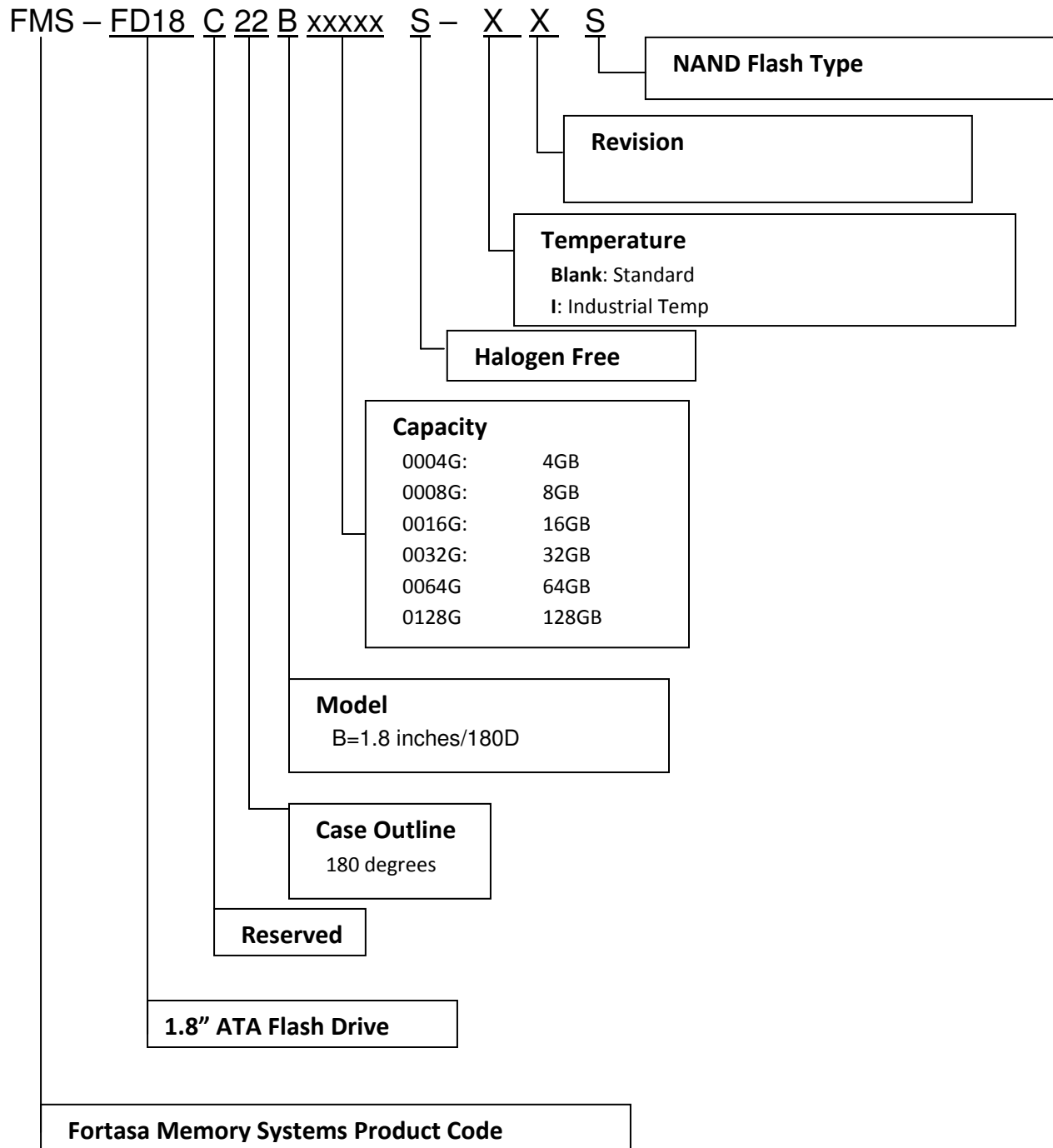

9.2 Valid Combinations

Standard Temperature		Industrial Temperature	
Capacity	Model Number	Capacity	Model Number
4GB	FMS-FD18C22B0004GS-T	4GB	FMS-FD18C22B0004GS-IT
8GB	FMS-FD18C22B0008GS-T	8GB	FMS-FD18C22B0008GS-IT
16GB	FMS-FD18C22B0016GS-T	16GB	FMS-FD18C22B0016GS-IT
32GB	FMS-FD18C22B0032GS-T	32GB	FMS-FD18C22B0032GS-IT
64GB	FMS-FD18C22B0064GS-C	64GB	FMS-FD18C22B0064GS-IC
128GB	FMS-FD18C22B0128GS-C	128GB	FMS-FD18C22B0128GS-IC



10. Revision History

Revision	Date	Description	Comments
1.0	9/4/2012	Initial Release	