

RoHS Compliant
SATA High Capacity Flash Drive Series
Datasheet for SAFD 25N2-M

December 9, 2016

Revision 1.1

***This Specification Describes the Features and Capabilities of
the Standard and Industrial Temperature
SATA Flash Drives***

***Please Contact Fortasa Memory Systems Sales for any
Custom Features Required For Your Specific Application***



1111 Triton Drive
Suite 100
Foster City, CA 94404 USA
888-367-8588
www.fortasa.com

SATA Flash Drive – 2.5”

FMS-SAFD25N2Xxxxx-XAxxXX



Features:

- **Standard Serial SATA 3.2**
 - SATA 3.2 command set compatible
 - Serial SATA 6.0 Gbps Interface
 - Backward compatible with SATA 1.5 and 3.0 Gbps interfaces
 - ATA-8 compatible command set
- **Low power consumption (typical)**
 - Supply voltage: 5V±5%
 - Active mode: 800 mA
 - Idle mode: 85 mA
- **Connector Type**
 - 7-pin signal connector
 - 15-pin power connector
- **Performance**
 - Burst transfer rate: 600 MB/sec
 - Sustained read: up to 560 MB/sec
 - Sustained write: up to 500 MB/sec
 - Random read (4K): up to 42,000 IOPS
 - Random write (4K): up to 26,000 IOPS
- **Capacity**
 - 64, 128, 256, 512 GB, 1, 2 TB
- **Intelligent endurance design**
 - Built-in hardware ECC, enabling up to 120 bit correction per 2048 bytes
 - Global wear-leveling scheme together with dynamical block allocation to significantly increase the lifetime of a flash device and optimize the disk performance
 - Flash bad-block management
 - *Power Failure Management*
 - *ATA Secure Erase*
 - *SMART Command*
 - *Trim Command*
- **Form factor**
 - Dimensions for 7mm housing: 100.00 x 69.85 x 7.00, unit: mm
- **Thermal Sensor for Temperature Management**
- **Security**
 - AES 256 Hardware Encryption
 - SHA 512
 - RSA2048
 - TCG OPAL SSC V1.0 Compliant
- **RoHS compliant**
- **NAND flash type: MLC**
- **MTBF (hours):** >2,000,000
- **Endurance**
 - 64GB – 128 TBW
 - 128GB – 257 TBW
 - 256GB – 514 TBW
 - 512GB – 1028 TBW
 - 1TB – 2057 TBW
 - 2TB – 4114 TBW
- **Temperature ranges**
 - Operation:
 - Standard: 0°C to 70°C
 - Industrial: -40°C to 85°C
 - Storage: -40°C to 100°C



Table of Contents

1 Product Description	4
1.1 General Description.....	4
1.2 Functional Block	4
1.3 Capacity Specification.....	4
1.4 Performance Specification	5
1.5 Pin Assignments.....	5
2. Software Interface	7
2.1 Command Set.....	7
3. Flash Management	8
3.1 Error Correction/Detection.....	8
3.2 Wear Leveling	8
3.3 Power Failure Management.....	8
3.4 ATA Secure Erase	8
3.5 S.M.A.R.T. Technology	8
3.6 TRIM Command Support.....	8
3.7 AES 256-bit Encryption	9
3.8 TCG OPAL SSC V1.0 Compliant.....	9
3.9 Thermal Sensor	9
4. Environmental Specifications	10
4.1 Environments	10
4.2 Mean Time Between Failures (MTBF)	10
4.3 Certification and Compliance.....	10
4.4 Endurance.....	10
5. Electrical Specification	11
5.1 Operating Voltage	11
5.2 Power Consumption	11
6. Physical Characteristics	12
6.1 7mm Thickness Enclosure.....	12
7. Product Ordering Information.....	13
7.1 Product Code Designations	13
7.2 Valid Combinations.....	14
8. Revision History	16

1 Product Description

1.1 General Description

Fortasa’s SAFD25N2-M is a high-performance, SATA interface, solid state drive (SSD) designed to replace a conventional SATA hard disk drive. SAFD supports standard SATA protocol and can be plugged into a standard SATA connector commonly found in rugged laptops, military devices, thin clients, Point of Sale (POS) terminals, telecom, medical instruments, surveillance systems and industrial PCs. Fortasa SAFD Series is the best drop-in replacement for high-maintenance HDD where reliability is of a major importance. Incorporating AES 256-bit Encryption Algorithm, the information stored in a SAFD25N2-M drive is most secure.

The SAFD25N2-M drive offers capacities of up to 2 Terabyte, providing full support for the SATA 6GBps high-speed interface standard. It can operate at sustained access rates of up to 560 megabytes per second, which is much faster than other solid-state or traditional HDD SATA drives currently available on the market. **Manufactured using Industrial Temperature rated MLC NAND-flash, this SSD can work in highly demanding environment and withstand wide range of operating temperature from -40°C to +85°C.**

SAFD25N2-M offers high reliability global data wear-leveling scheme to allow uniform use of all storage blocks, increasing the lifetime of Flash media and optimizing drive performance. The SAFD25N2-M also offers Self-Monitoring Analysis and Reporting Technology (S.M.A.R.T.) feature that follows the ATA/ATAPI specifications and uses the standard SMART command B0h to read data from the drive. This capability monitors the drive accesses and provides the host with vital information about drive condition to schedule maintenance and service times.

1.2 Functional Block

The SAFD25N2-M drive includes a SATA 6.0 Gps Flash Controller and flash media. The Flash controller integrates the flash management unit to support multi-channel, multi-bank flash arrays.

1.3 Capacity Specification

Standard capacity specification of the SATA Flash Drive product are shown in Table 1-1. The table lists the specific capacity and the default numbers of heads, sectors and cylinders (CHS) for each product line.

Table 1-1: Capacity specifications

Capacity	Total Bytes	Max LBA
64GB	62,522,712	125,045,424
128GB	117,220,824	234,441,648
256GB	234,431,064	468,862,128
512GB	468,851,544	937,703,088
1TB	937,692,504	1,875,385,008
2TB	1,875,374,424	3,750,748,848

Please contact factory for any non-listed SATA Flash Drive capacity or custom CHS requirement.

SATA Flash Drive – 2.5”

FMS-SAFD25N2XXXX-XAxxXX



1.4 Performance Specification

Performances of the SATA Flash Drive are listed in Table 1-2.

Table 1-2: High Performance specifications

Capacity \ Performance	64GB	128GB	256GB	512GB	1TB	2TB
Sustained read (MB/s)	510	510	510	510	510	560
Sustained write (MB/s)	460	460	460	460	400	540
Random Read IOPS (4K)	42,000	42,000	42,000	42,000	39,000	40,000
Random Write IOPS (4K)	26,000	26,000	26,000	26,000	16,000	18,000

Note: Performance varies from flash configurations or host system settings.
 IOPS: measured on 8GB span (16777216 sectors Disk Size), 32 Outstanding I/Os (QD=32), Full Random Data pattern, 4KB Align I/Os and test durations 15minutes

1.5 Pin Assignments

Figure 1-2: Micro-SATA connectors

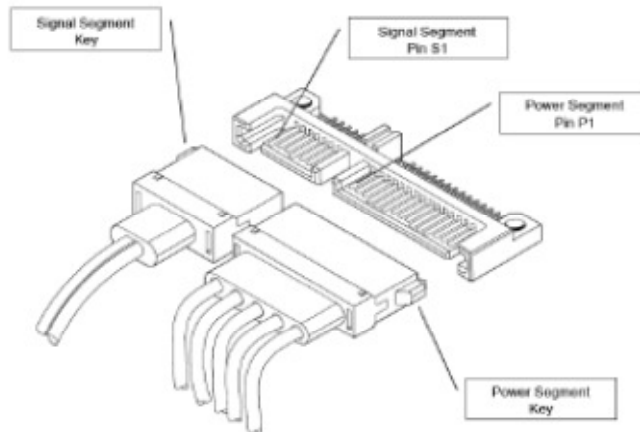

Table 1-3: Signal Segment

Pin	Signal	Description
S1		Ground
S2	RxP	Serial Data Receiver
S3	RxN	
S4		Ground
S5	TxN	Serial Data Transmitter
S6	TxP	
S7		Ground

Table 1-4: Power Segment

Pin	Signal
P1	Not Used (3.3V)
P2	Not Used (3.3V)
P3	Not Used (3.3V)
P4	Ground
P5	Ground
P6	Ground
P7	5V
P8	5V
P9	5V
P10	Ground
P11	Reserved
P12	Ground
P13	Not used (12V)
P14	Not Used (12V)
P15	Not Used (12V)

2. Software Interface

2.1 Command Set

Table 2-1 summarizes the command set with the paragraphs that follow describing the individual commands and the task file for each.

Table 2-1: Command set

Command	Code	Command	Code
Check-Power-Mode	E5H	Security-Disable-Password	F6H
Data Set Management	06h	Security-Erase-Prepare	F3H
DCO	B1h	Security-Erase-Unit	F4H
Download Microcode PIO	92h	Security-Freeze-Lock	F5H
Download Microcode DMA	93h	Security-Set-Password	F1H
Execute-Drive-Diagnostic	90H	Security-Unlock	F2H
Flush-Cache	E7H	Seek	7XH
Identify-Drive	ECH	Set-Features	EFH
Idle	E3H	Set MAX Address	F9H
Idle-Immediate	E1H	Set MAX Address EXT	37H
Initialize-Drive-Parameters	91H	Set-Multiple-Mode	C6H
Read Buffer	E4	Set-Sleep-Mode	E6H
Read DMA (W retry)	C8H	SMART	B0H
Read DMA (W/O retry)	C9H	Stand-By	E2H
Read DMA EXT	25H	Stand-By-Immediate	E0H
Read FPDMA Queued	60H	Write Buffer	E8H
Read Log EXT	2FH	Write DMA	CAH or CBH
Read-Multiple	C4H	Write DMA EXT	35H
Read-Multiple EXT	29H	Write DMA FUA EXT	3DH
Read Native Max Address	F8H	Write FPDMA Queued	61H
Read Native Max Ext	27H	Write Log EXT	3FH
Read-Sector(s)	20H or 21H	Write-Multiple	C5H
Read-Sector(s) EXT	24H	Write-Multiple EXT	39H
Read-Verify-Sectors	40H or 41H	Write-Multiple FUA EXT	CEH
Read-Verify-EXT	42H	Write-Sector(s)	30H or 31H
Recalibrate	10H	Write-Sector(s) EXT	34H
		Write Uncorrectable	45H

3. Flash Management

3.1 Error Correction/Detection

The SATA Flash Drive implements a hardware BCH-based ECC scheme to achieve up to 120 bit correction per 2048-bytes.

3.2 Wear Leveling

All NAND flash devices are limited by a finite number of write cycles. Under a standard file system, frequent file table updates are mandatory. As a painful side effect of OS file overhead, some areas of flash address space wear out faster than others. As these certain sections get a substantially higher write occurrence the whole SATA Flash Drive can wear out very quickly. This uneven wear would significantly reduce the lifetime of the whole device, even if majority of the Flash sectors are far from the write cycle limit. Fortasa's SATA Flash Drive products offer advanced data wear leveling which distributes Flash writes evenly across the SATA Flash Drive memory space. By utilizing this advanced wear leveling feature, the lifetime of the media can be significantly extended.

3.3 Power Failure Management

The Low Power Detection on the Flash controller initiates cached data saving before the power supply to the device drops too low for operation. This feature prevents the device from system crash and ensures data integrity during an unexpected brownout. This feature makes sure that there are no catastrophic failures of the SATA Flash Drive due to system power glitches.

Note: The Flash controller unit of this product model is designed with an External DRAM as a write cache for improved performance and data efficiency. Though unlikely to happen in most cases, the data cached in the volatile DRAM might be potentially affected if a sudden power loss / brown-out condition takes place before the cached data is flushed into non-volatile NAND flash memory.

3.4 ATA Secure Erase

Accomplished by the Secure Erase (SE) command, which added to the open ANSI standards that control disk drives, "ATA Secure Erase" is built into the disk drive itself and thus far less susceptible to malicious software attacks than external software utilities. It is a positive easy-to-use data destroy command, amounting to electronic data shredding. Executing the command causes a drive to internally completely erase all possible user data. This command is carried out within disk drives, so no additional software is required. The erase process will not stop until it is completed. In case of power failure, the erase process will continue when the power is reapplied to the device.

3.5 S.M.A.R.T. Technology

S.M.A.R.T. is an acronym for Self-Monitoring, Analysis and Reporting Technology, an open standard allowing disk drives to automatically monitor their own health and report potential problems. It protects the user from unscheduled downtime by monitoring and storing critical drive performance and calibration parameters. Ideally, this should allow taking proactive actions to prevent impending drive failure. Fortasa SMART feature follows the ATA/ATAPI specifications, using the standard SMART command B0h to read data from the drive. Fortasa SMART defines vendor-specified SMART Attribute IDs in the SATA Flash Drive products. They represent initial bad block count, total later bad block count, maximum erase count, average erase count, power on hours and power cycle. Please contact Fortasa sales for SMART ID definitions.

3.6 TRIM Command Support

Over time the performance of SSD degrades as user continually writes and erases data. The ATA-TRIM command "formats" the SSD to optimize the drive performance. A TRIM enabled SSD running an OS with TRIM support will stay closer to its peak performance without much performance variance.

3.7 AES 256-bit Encryption

SAFD25N2-M incorporates Advanced Encryption Standard (AES) 256-bit which is an industry standard in data security and has been adopted by U.S. government and now widely used for symmetric-key data encrypting in order to meet higher level of data security requirements.

3.8 TCG OPAL SSC V1.0 Compliant

OPAL SSC (Security Subsystem Class) is specified by Trusted Computing Group. It is to define key management and access control features for self-encrypting drives. This specification uses a concept of pre-boot partition for user authentication. It is an optional authentication method in addition to ATA security. However, due to restriction on OPAL SSC specification, ATA security command will be disabled under OPAL SSC mode.

3.9 Thermal Sensor

SAFD25N2-M contains a Thermal Sensor that measures module temperature. The module temperature can be obtained by polling SMART Command attribute ID 194 (0xC2). When the device temperature reaches a pre-set temperature threshold, the module performance will be reduced to limit the power draw and prevent the module from overheating.

4. Environmental Specifications

4.1 Environments

Environmental specification of the SATA Flash Drive series follows the MIL-STD-810F standard as shown in Table 4-1.

Table 4-1: Environmental specifications

Environment		Specification
Temperature	Operation	0°C to +70°C (standard); -40°C to +85°C (industrial)
	Storage	-40°C to +100°C
Vibration		Sine wave: 5~55~5 Hz (X, Y, Z) Random: 10-2000 Hz, 16.3 G (X, Y, Z)
Shock-Operating		Acceleration: 1,500 G, 0.5 ms Peak acceleration: 50 G, 11 ms

4.2 Mean Time Between Failures (MTBF)

Mean Time Between Failures (MTBF) is predicted based on reliability data for the individual components in the SAFD drive. Based on provided component data, SATA Flash Drive is rated at more than 2,000,000 hours.

Notes about the MTBF:

The MTBF is predicated and calculated based on “Telcordia Technologies Special Report, SR-332, Issue 2” method.

4.3 Certification and Compliance

The SAFD25N2-M complies with the following standards:

- CE
- FCC
- RoHS

4.4 Endurance

The endurance of a storage device is predicted by a JEDEC approved test methodology. The data, reported in TeraBytes Written, is based on several factors related to device architecture and product usage, such as the amount of data written into the drive, block management conditions, and daily workload for the drive. Please contact Sales to learn more about the TBW analysis and calculations.

Capacity	TBW
64GB	128
128GB	257
256GB	514
512GB	1028
1TB	2057
2TB	4114

Notes:

- The measurement assumes the data written to the SSD for test is under a typical and constant rate.
- The measurement follows the standard metric: 1 TB (Terabyte) = 1000 GB.

5. Electrical Specification

5.1 Operating Voltage

Caution: Absolute Maximum Stress Ratings – Applied conditions greater than those listed under “Absolute Maximum Stress Ratings” may cause permanent damage to the device. This is a stress rating only and functional operation of the device at these conditions or conditions greater than those defined in the operational sections of this data sheet is not implied. Exposure to absolute maximum stress rating conditions may affect device reliability.

Table 5-1: Operating range

Range	Ambient Temperature	Conditions
Commercial	0°C to +70°C	5.0 V ±5% (4.75-5.25 V)
Industrial	-40°C to +85°C	5.0 V ±5% (4.75-5.25 V)

5.2 Power Consumption

Table 5-2 lists the SAFD 25N2-M power consumption.

Table 5-2 Typical power consumption

Performance \ Capacity	Capacity					
	64GB	128GB	256GB	512GB	1TB	2TB
Active Mode (mA)	460	460	720	870	890	1080
Idle Mode (mA)	40	55	55	60	60	60

6. Physical Characteristics

6.1 7mm Thickness Enclosure

Figure 6-1 illustrates the overall dimensions of the SAFD drive packaged in a 7mm Housing, as listed in Table 6-1.

Table 6-1 SAFD dimensions

Dimension	Millimeters (mm)
Height	7.00 ± 0.20
Width	69.85 ± 0.25
Length	100.00 ± 0.33

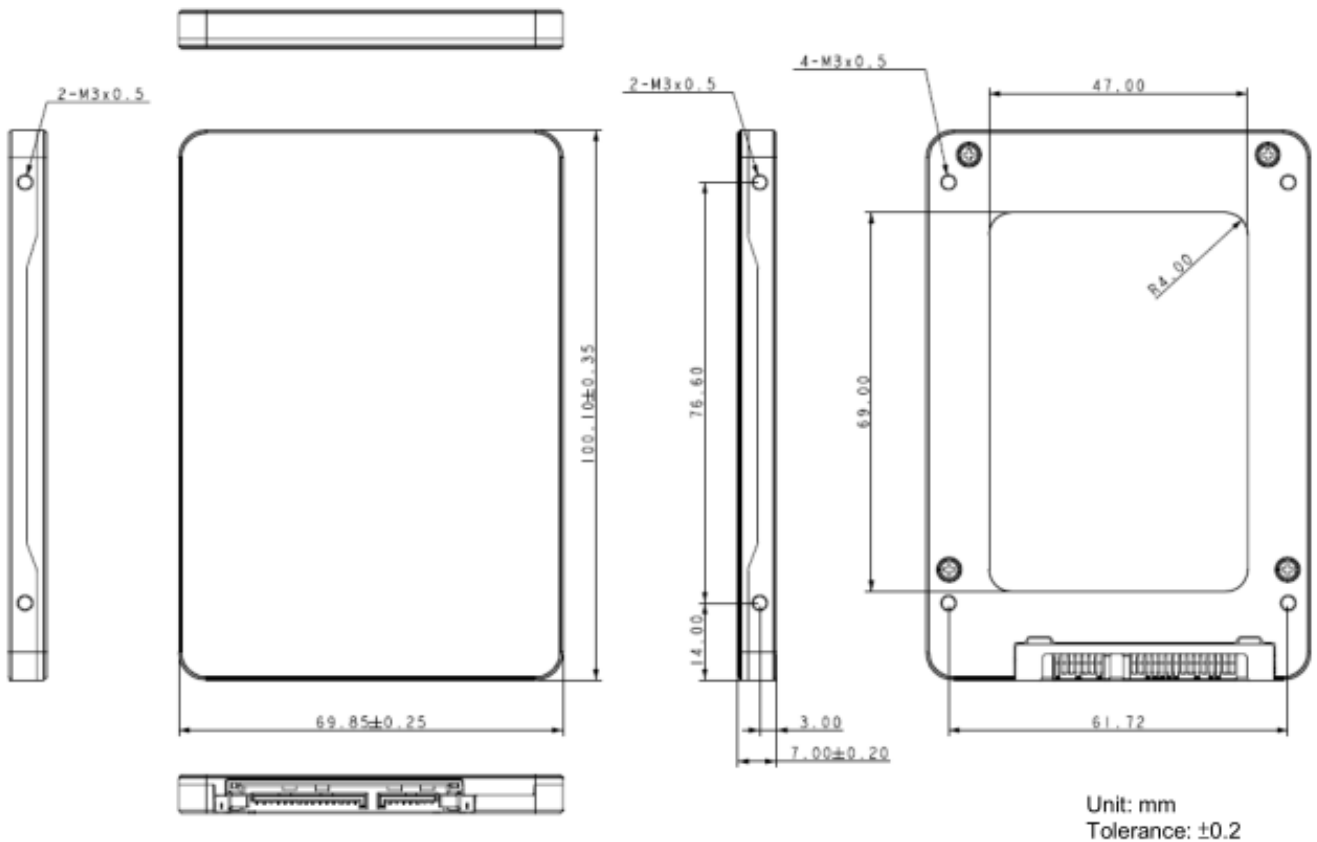
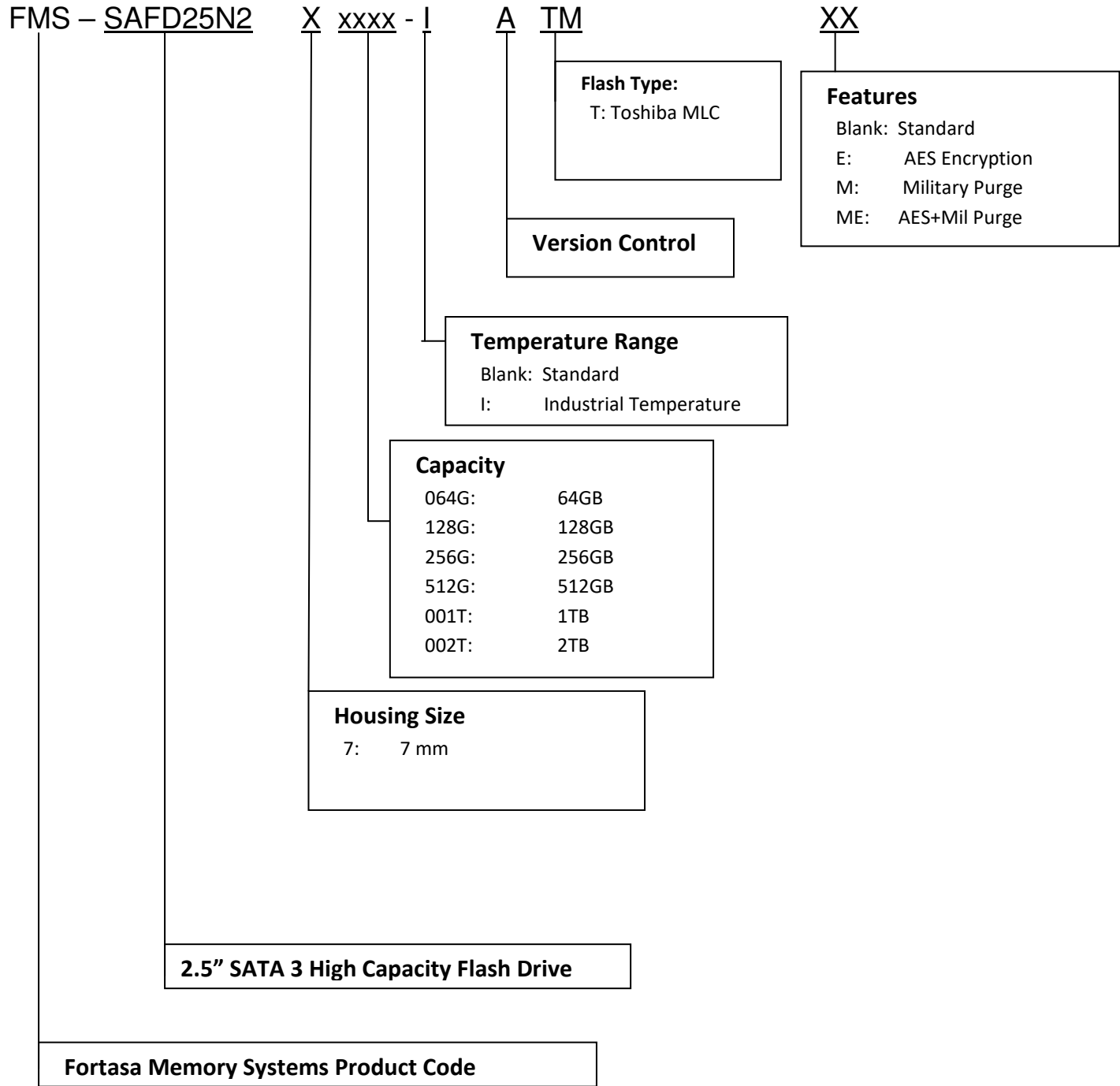

Figure 6-1 SFD25N2-M with 7mm Housing physical dimensions

7. Product Ordering Information

7.1 Product Code Designations



7.2 Valid Combinations

7mm Housing

Standard Configuration

Capacity	Standard Temperature Model Numbers	Industrial Temperature Model Numbers
64GB	FMS-SAFD25N27064G-ATM	FMS-SAFD25N27064G-IATM
128GB	FMS-SAFD25N27128G-ATM	FMS-SAFD25N27128G-IATM
256GB	FMS-SAFD25N27256G-ATM	FMS-SAFD25N27256G-IATM
512GB	FMS-SAFD25N27512G-ATM	FMS-SAFD25N27512G-IATM
1TB	FMS-SAFD25N27001T-ATM	FMS-SAFD25N27001T-IATM
2TB	FMS-SAFD25N27002T-ATM	FMS-SAFD25N27002T-IATM

AES Encryption

Capacity	Standard Temperature Model Numbers	Industrial Temperature Model Numbers
64GB	FMS-SAFD25N27064G-ATME	FMS-SAFD25N27064G-IATME
128GB	FMS-SAFD25N27128G-ATME	FMS-SAFD25N27128G-IATME
256GB	FMS-SAFD25N27256G-ATME	FMS-SAFD25N27256G-IATME
512GB	FMS-SAFD25N27512G-ATME	FMS-SAFD25N27512G-IATME
1TB	FMS-SAFD25N27001T-ATME	FMS-SAFD25N27001T-IATME
2TB	FMS-SAFD25N27002T-ATME	FMS-SAFD25N27002T-IATME

Military Purge

Capacity	Standard Temperature Model Numbers	Industrial Temperature Model Numbers
64GB	FMS-SAFD25N27064G-ATMM	FMS-SAFD25N27064G-IATMM
128GB	FMS-SAFD25N27128G-ATMM	FMS-SAFD25N27128G-IATMM
256GB	FMS-SAFD25N27256G-ATMM	FMS-SAFD25N27256G-IATMM
512GB	FMS-SAFD25N27512G-ATMM	FMS-SAFD25N27512G-IATMM
1TB	FMS-SAFD25N27001T-ATMM	FMS-SAFD25N27001T-IATMM
2TB	FMS-SAFD25N27002T-ATMM	FMS-SAFD25N27002T-IATMM

SATA Flash Drive – 2.5”

FMS-SAFD25N2XXXX-XAxxXX



AES Encryption + Military Purge

Capacity	Standard Temperature Model Numbers	Industrial Temperature Model Numbers
64GB	FMS-SAFD25N27064G-ATMEM	FMS-SAFD25N27064G-IATMEM
128GB	FMS-SAFD25N27128G-ATMEM	FMS-SAFD25N27128G-IATMEM
256GB	FMS-SAFD25N27256G-ATMEM	FMS-SAFD25N27256G-IATMEM
512GB	FMS-SAFD25N27512G-ATMEM	FMS-SAFD25N27512G-IATMEM
1TB	FMS-SAFD25N27001T-ATMEM	FMS-SAFD25N27001T-IATMEM
2TB	FMS-SAFD25N27002T-ATMEM	FMS-SAFD25N27002T-IATMEM

Note: Valid combinations are those products in mass production or will be in mass production. Consult your Fortasa sales representative to confirm availability of valid combinations and to determine availability of new product combinations



8. Revision History

Revision	Date	Description	Comments
1.0	4/20/2016	Initial Release	
1.1	12/9/2016	Added AES Encryption and Military Purge Information	