

**RoHS Compliant**

Slim SATA Flash Module - MO-297 Series

**Datasheet for S297-D 3D NAND Slim SATA Flash Module**

**March 26, 2020**

**Revision 1.0**

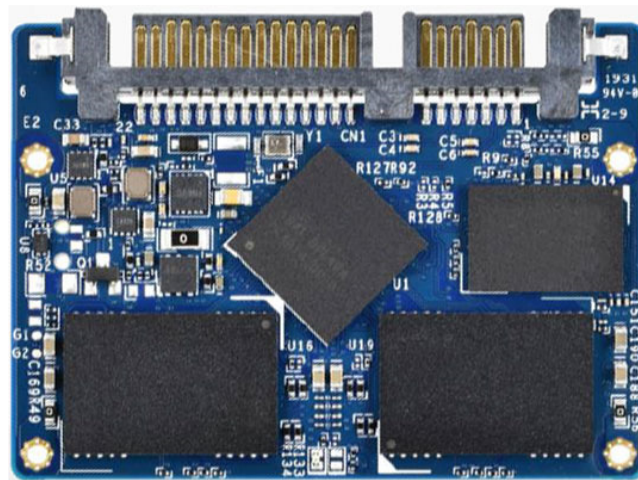

***This Specification Describes the Features and Capabilities of the Standard and Industrial Temperature MO-297 SATA Modules***

***Please Contact Fortasa Memory Systems Sales for any Custom Features Required For Your Specific Application***



1670 Amphlett Blvd  
Suite 214-33  
San Mateo, CA 94402 USA  
888-367-8588  
www.fortasa.com

# Slim SATA Flash Drive

## FMS-S297DxxxxA-xDx



### Features:

- **Compliant with Serial SATA Revision 3.1**
  - SATA 3.1 command set compatible
  - Serial SATA 3 – 6.0 Gbps interface
  - ATA-8 compatible command set
- **Temperature ranges**
  - Operation:
    - Standard Temperature: 0°C to 70°C
    - Industrial Temperature: -40°C to 85°C
  - Storage: -40°C to 100°C
- **NAND flash type: 3D TLC (BiCS3)**
- **Performance**
  - Burst transfer rate: 600 MB/sec
  - Performance
    - Sustained Read: up to 560 MB/sec
    - Sustained Write: up to 510 MB/sec
    - Random read 4K: up to 97,000 IOPS
    - Random write 4K: up to 85,000 IOPS
- **Connector Type**
  - 52-pin Slim SATA connector
- **Form factor**
  - Dimensions - 50.8 x 29.85 x 4.85, unit: mm
  - JEDEC MO-300 compliant
  - Net Weight: 7.80 g
- **Intelligent endurance design**
  - Built-in hardware ECC, based on Low Density Parity Check (LDPC) algorithm
  - Global wear-leveling scheme together with dynamical block allocation to significantly increase the lifetime of a flash device and optimize the disk performance
  - Flash bad-block management
  - SMART Command
  - *Power Failure Management*
  - *ATA Secure Erase*
  - *Trim Command*
- **Thermal Sensor for Temperature Management**
- **Endurance (in Drive Writes Per Day (DWPD))**
  - 30 GB: 1.59 DWPD
  - 60 GB: 1.97 DWPD
  - 120 GB: 2.94 DWPD
  - 240 GB: 3.03 DWPD
  - 480 GB: 3.01 DWPD
  - 960 GB: 3.13 DWPD
- **Capacity**
  - 30GB, 60GB, 120GB, 240GB, 480GB, 960GB
- **Low power consumption (typical)**
  - Supply voltage: 5.0 V ± 5%
  - Active mode: 530 mA
  - Idle mode: 100 mA
- **MTBF - >1,000,000 hours**
- **Security**
  - AES 256 Hardware Encryption
  - Trusted Computing Group (TCG) Opal 2.0 (optional)

---

## Table of Contents

1 Product Description .....	5
1.1 General Description.....	5
1.2 Capacity Specification.....	5
1.3 Performance Specification .....	6
1.4 Pin Assignments.....	6
1.5 LED Indicator Behavior .....	8
2. Software Interface .....	9
2.1 Command Set.....	9
3. Flash Management .....	10
3.1 Error Correction/Detection.....	10
3.2 Wear Leveling .....	10
3.3 Power Failure Management.....	10
3.4 ATA Secure Erase.....	10
3.5 S.M.A.R.T. Technology .....	11
3.6 TRIM Command Support.....	12
3.7 SATA Power Management .....	12
3.8 Thermal Sensor .....	12
3.9 AES 256-bit Encryption .....	12
3.10 TCG OPAL SSC V2.0 Compliant.....	12
4. Environmental Specifications .....	13
4.1 Environments .....	13
4.2 Mean Time Between Failures (MTBF) .....	13
4.3 Certification and Compliance.....	13
4.4 Endurance.....	14
5. Electrical Specification .....	15
5.1 Operating Voltage .....	15
5.2 Power Consumption .....	15
6. Physical Characteristics .....	16
6.1 Dimensions.....	16
6.1 Net Weight .....	16
7. Product Ordering Information.....	17

# Slim SATA Flash Drive

## FMS-S297DxxxxA-xDx



---

7.1 Product Code Designations .....	17
7.2 Valid Combinations.....	18
8. Revision History .....	19

## 1 Product Description

### 1.1 General Description

Fortasa's Slim SATA A-D is a high-performance, SATA interface, solid state drive (SSD) designed to replace a conventional SATA hard disk drive. Slim SATA supports standard SATA protocol and can be plugged into a standard mini PCIe connector commonly found in rugged laptops, military devices, thin clients, Point of Sale (POS) terminals, telecom, medical instruments, surveillance systems and industrial PCs. Complying with JEDEC MO-300 standard, the Slim SATA SSD is a widely adopted embedded storage with compact size and exceptional performance.

The Slim SATA A-D drive offers capacity of 960 gigabytes, providing full support for the SATA 6.0Gbit high-speed interface standard. It can operate at sustained access rates of up to 560 megabytes per second, which is much faster than other solid-state or traditional HDD SATA drives currently available on the market. **Manufactured using Industrial Temperature rated 3D NAND-flash, this SSD can work in highly demanding environment and withstand wide range of operating temperature from -40°C to +85°C.**

Slim SATA A-D is implemented using LDPC (Low Density Parity Check) ECC engine to extend SSD endurance and increase data reliability inside a flash chip. Additionally the drive offers high reliability global data wear-leveling algorithm to allow uniform use of all storage blocks, increasing the lifetime of Flash media and optimizing drive performance. The Slim SATA A-D also offers Self-Monitoring Analysis and Reporting Technology (S.M.A.R.T.) feature that monitors the drive accesses and provides the host with vital information about drive condition to schedule maintenance and service times.

### 1.2 Capacity Specification

Standard capacity specification of the Slim SATA A-D Flash Drive product is shown in Table 1-1. The table lists the specific capacity and the default numbers of heads, sectors and cylinders (CHS).

**Table 1-1: Capacity specifications**

Capacity	Total Bytes	Cylinders	Heads	Sectors	Max LBA
30GB	30,016,659,456	16383 <sup>1</sup>	16	63	58,626,288
60GB	60,022,480,896	16383 <sup>1</sup>	16	63	117,231,408
120GB	120,034,123,776	16383 <sup>1</sup>	16	63	234,441,648
240GB	240,057,409,536	16383 <sup>1</sup>	16	63	468,862,128
480GB	480,103,981,056	16383 <sup>1</sup>	16	63	937,703,088
960GB	960,197,124,096	16383 <sup>1</sup>	16	63	1,875,385,008

1. Cylinders, heads or sectors are not applicable for these capacities. Only LBA addressing applies.

*Please contact factory for any non-listed SATA Flash Drive capacity or custom CHS requirement.*

### 1.3 Performance Specification

Performance of the Slim SATA A-D Flash Drive is listed in Table 1-2.

**Table 1-2:** Performance specifications

Performance \ Capacity	30GB	60GB	120GB	240GB	480GB	960GB
<b>Sustained read (MB/s)</b>	295	555	560	560	560	560
<b>Sustained write (MB/s)</b>	125	245	480	500	505	520
<b>Random Read IOPS (4K)</b>	19,000	38,000	66,000	96,000	96,000	96,000
<b>Random Write IOPS (4K)</b>	29,000	60,000	83,000	85,000	85,000	85,000

Note: Performance varies from flash configurations or host system settings.

### 1.4 Pin Assignments

**Figure 1-2:** SATA connectors

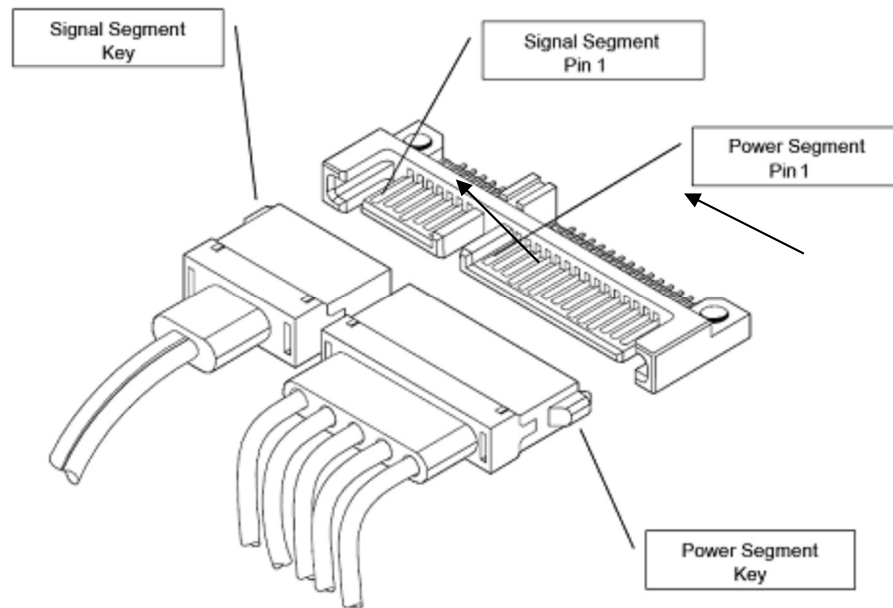
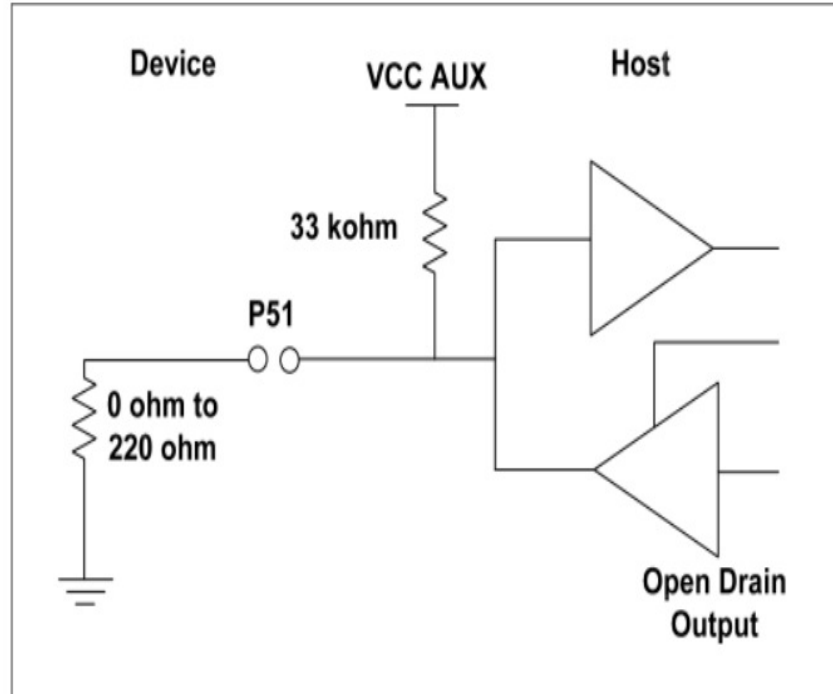

**Table 1-3:** Signal Segment

Pin	Signal	Description
S1		Ground
S2	RxP	Serial Data Receiver
S3	RxN	
S4		Ground
S5	TxN	Serial Data Transmitter
S6	TxP	
S7		Ground

**Table 1-4: Power Segment**

Pin	Signal
P1	Not Used (3.3V)
P2	Not Used (3.3V)
P3	Not Used (3.3V)
P4	Ground
P5	Ground
P6	Ground
P7	5V
P8	5V
P9	5V
P10	Ground
P11	DAS
P12	Ground
P13	Not used (12V)
P14	Not Used (12V)
P15	Not Used (12V)



**Bi-directional host-side implementation of P51 for compatibility with non-mSATA devices (Informative)**

# Slim SATA Flash Drive

## FMS-S297DxxxxA-xDx



### 1.5 LED Indicator Behavior

The behavior of the Slim SATA A-D Flash Drive device LED indicators is described in Table 1-4.

**Table 1-4:** LED Behavior

Location	Status	Description
LED A	DAS	LED blinks when the drive is being accessed

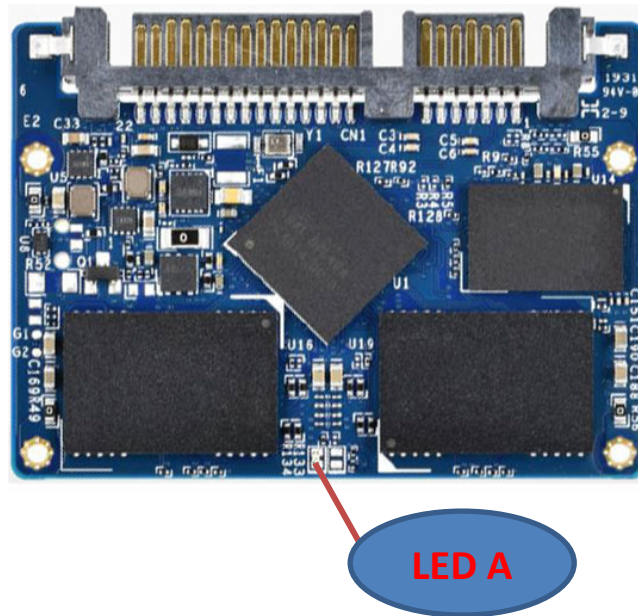



## 2. Software Interface

### 2.1 Command Set

Table 2-1 summarizes the Slim SATA A-D command set.

**Table 2-1:** Command set

Command	Code	Command	Code
Check-Power-Mode	E5H	Recalibrate	10H
Execute-Drive-Diagnostic	90H	Security-Freeze-Lock	F5H
Flush-Cache	E7H	Security-Set-Password	F1H
Identify-Drive	ECH	Security-Unlock	F2H
Idle	E3H	Seek	7xH
Idle-Immediate	E1H	Set-Features	EFH
Initialize-Drive-Parameters	91H	SMART	B0H
Read DMA	C8H	Set-Multiple-Mode	C6H
Read DMA EXT	25H	Set-Sleep-Mode	E6H
Read FPDMA Queued	60H	Stand-By	E2H
Read Log DMA EXT	47H	Stand-By-Immediate	E0H
Read Log EXT	2FH	Write DMA	CAH
Read-Multiple	C4H	Write DMA EXT	35H
Read-Sector	20H	Write Log DMA EXT	57H
Read-Verify-Sectors	40H	Write FPDMA Queued	61H
Security-Disable-Password	F6H	Write Log EXT	3FH
Security-Erase-Prepare	F3H	Write-Multiple	C5H
Security-Erase-Unit	F4H	Write-Sector	30H

---

### 3. Flash Management

#### 3.1 Error Correction/Detection

The Slim SATA A-D implements a hardware ECC scheme, based on the Low Density Parity Check (LDPC). LDPC is a new class of linear block error correcting code which has substantial coding gain over previously common BCH code due to LDPC code integrating both hard decoding and soft decoding algorithms. With the reduced bit error rate, LDPC can extend SSD endurance and increase data reliability.

#### 3.2 Wear Leveling

All NAND flash devices are limited by a finite number of write cycles. Under a standard file system, frequent file table updates are mandatory. As a painful side effect of OS file overhead, some areas of flash address space wear out faster than others. As these certain sections get a substantially higher write occurrence the whole Flash Drive can wear out very quickly. This uneven wear would significantly reduce the lifetime of the whole device, even if majority of the Flash sectors are far from the write cycle limit. Fortasa's Slim SATA A-D Flash Drive products offer advanced data wear leveling which distributes Flash writes evenly across the SATA Flash Drive memory space. By utilizing this advanced wear leveling feature, the lifetime of the media can be significantly extended.

#### 3.3 Power Failure Management

The Low Power Detection on the Flash controller initiates cached data saving before the power supply to the device drops too low for operation. This feature prevents the device from system crash and ensures data integrity during an unexpected brownout. This feature makes sure that there are no catastrophic failures of the SATA Flash Drive due to system power glitches.

#### 3.4 ATA Secure Erase

Accomplished by the Secure Erase (SE) command, which is part of the ANSI standards that control disk drives, "ATA Secure Erase" is built into the disk drive itself and thus far less susceptible to malicious software attacks than external software utilities. Execution of this command amounts to electronic data shredding and causes the SSD to internally completely erase all possible user data. Aside from user data, all data erase counters and other internal controller information stored on the Flash media will be also permanently deleted. The erase process will not stop until it is completed. In case of power failure, the erase process will continue when the power is reapplied to the device.

### 3.5 S.M.A.R.T. Technology

S.M.A.R.T. is an acronym for Self-Monitoring, Analysis and Reporting Technology, an open standard allowing disk drives to automatically monitor their own health and report potential problems. It protects the user from unscheduled downtime by monitoring and storing critical drive performance and calibration parameters. Ideally, this should allow taking proactive actions to prevent impending drive failure.

Code	SMART Subcommand
D0h	READ DATA
D1h	READ ATTRIBUTE THRESHOLDS
D2h	Enable/Disable Attribute Autosave
D4h	Execute Off-line Immediate
D5h	Read Log (optional)
D6h	Write Log (optional)
D8h	Enable Operations
D9h	Disable operations
DAh	Return Status

#### General SMART attribute structure

Byte	Description
0	ID (Hex)
1 – 2	Status flag
3	Value
4	Worst
5*-11	Raw Data

\*Byte 5: LSB

#### SMART attribute ID list

ID (Hex)	Attribute Name
9 (0x09)	Power-on hours
12 (0x0C)	Power cycle count
163 (0xA3)	Max. erase count
164 (0xA4)	Avg. erase count
166 (0xA6)	Total later bad block count
167 (0xA7)	SSD Protect Mode (vendor specific)
168 (0xA8)	SATA PHY Error Count
171 (0xAB)	Program fail count
172 (0xAC)	Erase fail count
175 (0xAF)	Bad Cluster Table Count
192 (0xC0)	Unexpected Power Loss Count
194 (0xC2)	Temperature
231 (0xE7)	Lifetime left
241 (0xF1)	Total sectors of write

---

### 3.6 TRIM Command Support

Over time the performance of SSD degrades as user continually writes and erases data. The ATA-TRIM command “formats” the SSD to optimize the drive performance. A TRIM enabled SSD running an OS with TRIM support will stay closer to its peak performance without much performance variance.

### 3.7 SATA Power Management

The Slim SATA A-D devices support the following SATA power saving modes:

- ACTIVE: PHY ready, full power, Tx & Rx operational
- PARTIAL: Reduces power, resumes in under 10  $\mu$ s (microseconds)
- SLUMBER: Reduces power, resumes in under 10 ms (milliseconds)
- HIPM: Host-Initiated Power Management
- DIPM: Device-Initiated Power Management
- AUTO-SLUMBER: Automatic transition from partial to slumber.

Note:

1. The behaviors of power management features depend on host/device settings.

### 3.8 Thermal Sensor

Slim SATA A-D contains a Thermal Sensor that measures module temperature. The module temperature can be obtained by polling SMART Command attribute ID 194 (0xC2). When the device temperature reaches a pre-set temperature threshold, the module performance will be reduced to limit the power draw and prevent the module from overheating.

### 3.9 AES 256-bit Encryption

Slim SATA A-D incorporates Advanced Encryption Standard (AES) 256-bit which is an industry standard in data security and has been adopted by U.S. government and now widely used for symmetric-key data encrypting in order to meet higher level of data security requirements.

### 3.10 TCG OPAL SSC V2.0 Compliant

OPAL SSC (Security Subsystem Class) is specified by Trusted Computing Group. It is to define key management and access control features for self-encrypting drives. This specification uses a concept of pre-boot partition for user authentication. It is an optional authentication method in addition to ATA security. However, due to restriction on OPAL SSC specification, ATA security command will be disabled under OPAL SSC mode.

## 4. Environmental Specifications

### 4.1 Environments

Environmental specification of the Slim SATA A-D Flash Drive series follows the MIL-STD-810F standard as shown in Table 4-1.

**Table 4-1:** Environmental specifications

Environment		Specification
Temperature	Operation	0°C to 70°C (Standard); -40°C to 85°C (Industrial)
	Storage	-40°C to 100°C
Operating Vibration		7.69 GRMS, 20~2000 Hz/random (compliant with MIL-STD-810G)
Non-Operating Vibration		4.02 GRMS, 15~2000 Hz/random (compliant with MIL-STD-810G)
Operating Shock		50G, 11ms
Non-Operating Shock		1500G, 0.5ms (compliant with MIL-STD-883K)

Note: This Environmental Specification table indicates the conditions for testing the device. Real world usages may affect the results.

### 4.2 Mean Time Between Failures (MTBF)

Mean Time Between Failures (MTBF) is predicted based on reliability data for the individual components in the SAFD drive. Based on provided component data, Slim SATA A-D Flash Drive is rated at more than 1,000,000 hours.

Notes about the MTBF:

The MTBF is predicated and calculated based on “Telcordia Technologies Special Report, SR-332, Issue 2” method.

### 4.3 Certification and Compliance

The Slim SATA A-D complies with the following standards:

- CE
- FCC
- RoHS
- MIL-STD-810F

### 4.4 Endurance

The endurance of a storage device is predicted by a JEDEC approved test methodology. The data, reported in Data Writes Per Day (DWPD), is based on several factors related to device architecture and product usage, such as the amount of data written into the drive, block management conditions, and daily workload for the drive. Please contact Sales to learn more about this analysis and calculations.

Capacity	DWPD
30GB	1.59
60GB	1.97
120GB	2.94
240GB	3.03
480GB	3.01
960GB	3.13

Notes:

This estimation complies with JEDEC JESD-219A random client workload.

- Flash vendor guaranteed 3D NAND TLC P/E cycle: 3K
- WAF may vary from capacity, flash configurations and writing behavior on each platform.
- 1 Terabyte = 1,024GB
- DWPD (Drive Writes Per Day) is calculated the number of times that user can overwrite the entire capacity of an SSD per day of its lifetime during the warranty period. (3D NAND TLC warranty: 2 years)

## 5. Electrical Specification

### 5.1 Operating Voltage

**Caution: Absolute Maximum Stress Ratings** – Applied conditions greater than those listed under “Absolute Maximum Stress Ratings” may cause permanent damage to the device. This is a stress rating only and functional operation of the device at these conditions or conditions greater than those defined in the operational sections of this data sheet is not implied. Exposure to absolute maximum stress rating conditions may affect device reliability.

**Table 5-1:** Operating range

Range	Ambient Temperature	Power
Standard	0°C to +70°C	5V ± 5% (4.75-5.25V)
Industrial	-40°C to +85°C	

### 5.2 Power Consumption

Tables 5-2 lists the Slim SATA A-D power consumption.

**Table 5-2** Slim SATA A-D power consumption (typical)

Performance \ Capacity	30GB	60GB	120GB	240GB	480GB	960GB
	<b>Active Mode (mA)</b>	295	380	465	495	515
<b>Idle Mode (mA)</b>	95	95	100	100	100	100

Note: Results may differ from various flash configurations or host system setting.

## 6. Physical Characteristics

### 6.1 Dimensions

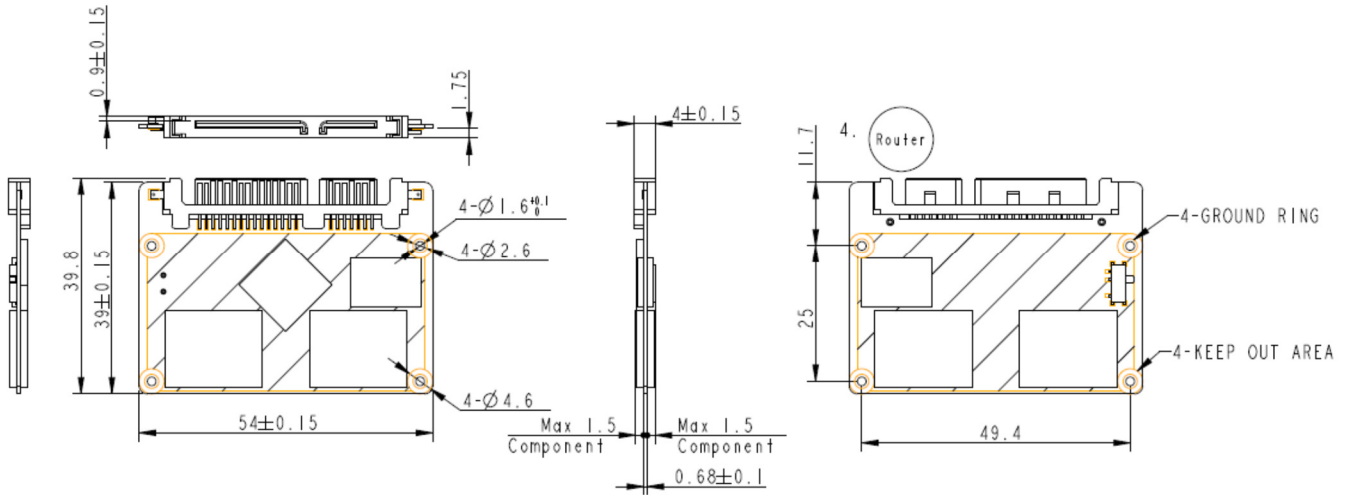

Units: mm

### 6.1 Net Weight

Capacity	Net Weight (g)
30GB	5.38
60GB	5.44
120GB	6.56
240GB	6.56
480GB	7.56
960GB	7.56



## 7. Product Ordering Information

### 7.1 Product Code Designations

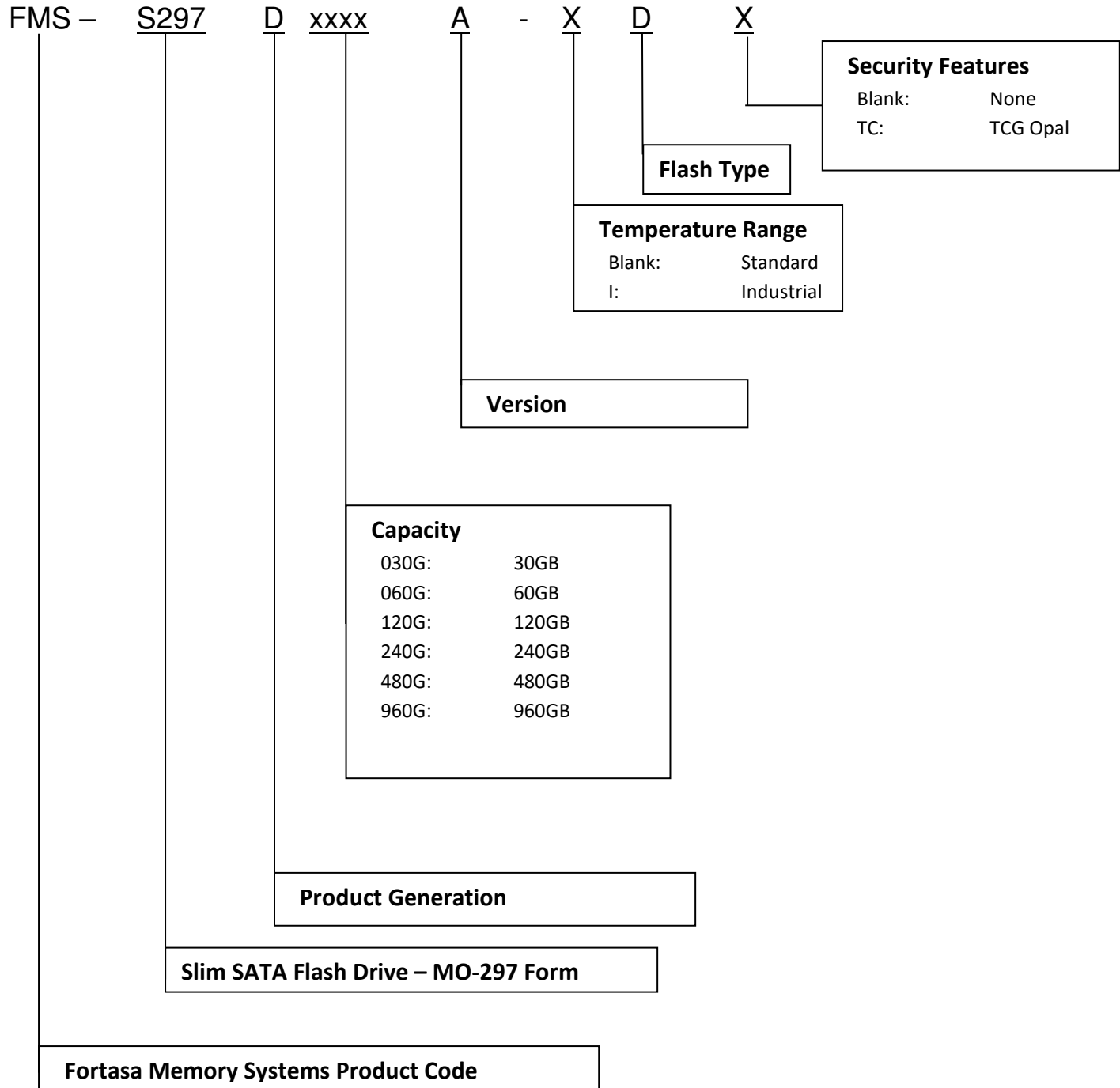

## 7.2 Valid Combinations

### Slim SATA A-D TCG Opal Not Enabled

Capacity	Standard Temperature	Industrial Temperature
30GB	FMS-S297D030GA-D	FMS-S297D030GA-ID
60GB	FMS-S297D060GA-D	FMS-S297D060GA-ID
120GB	FMS-S297D120GA-D	FMS-S297D120GA-ID
240GB	FMS-S297D240GA-D	FMS-S297D240GA-ID
480GB	FMS-S297D480GA-D	FMS-S297D480GA-ID
960GB	FMS-S297D960GA-D	FMS-S297D960GA-ID

### Slim SATA A-D – TCG Opal Enabled

Capacity	Standard Temperature	Industrial Temperature
30GB	FMS-S297D030GA-DT	FMS-S297D030GA-IDT
60GB	FMS-S297D060GA-DT	FMS-S297D060GA-IDT
120GB	FMS-S297D120GA-DT	FMS-S297D120GA-IDT
240GB	FMS-S297D240GA-DT	FMS-S297D240GA-IDT
480GB	FMS-S297D480GA-DT	FMS-S297D480GA-IDT
960GB	FMS-S297D960GA-DT	FMS-S297D960GA-IDT

**Note:** Valid combinations are those products in mass production or will be in mass production. Consult your Fortasa sales representative to confirm availability of valid combinations and to determine availability of new product combinations

---

## 8. Revision History

Revision	Date	Description	Comments
1.0	3/26/2020	Initial Release	

Copyright © 2020 Fortasa Memory Systems, Inc. All Rights Reserved.

Information in this document is subject to change without prior notice.

Fortasa name and the Fortasa logo are trademarks or registered trademarks of  
Fortasa Memory Systems, Inc.

Other brands, names, trademarks or registered trademarks may be claimed as the property of  
their respective owners.