

***RoHS Compliant***  
**SATA Flash Drive Series**  
***Datasheet for mini mSATA A family***

**September 6, 2017**

**Revision 1.5**



***This Specification Describes the Features and Capabilities of  
the Standard and Industrial Temperature  
mini mSATA Flash Drives***

***Please Contact Fortasa Memory Systems Sales for any  
Custom Features Required For Your Specific Application***



1111 Triton Dr  
Suite 100  
Foster City, CA 94404 USA  
888-367-8588  
www.fortasa.com

---

Features:

- **Compliant with Serial SATA Revision 3.1**
  - SATA 1.5 and 2 command set compatible
  - Serial SATA 3 – 6.0 Gbps interface
  - ATA-8 compatible command set
- **Temperature ranges**
  - Operation:
    - Standard Temperature: 0°C to 70°C
    - Enhanced Temperature: -40°C to 85°C
  - Storage: -40°C to 100°C
- **NAND flash type: SLC**
- **Performance**
  - Burst transfer rate: 600 MB/sec
  - Sustained Performance
    - Read: up to 65 MB/sec
    - Write: up to 60 MB/sec
    - Random read (4K): up to 15,000 IOPS
    - Random write (4K): up to 15,000 IOPS
- **Connector Type**
  - 52-pin mSATA connector
- **Form factor**
  - mSATA Mini (29.85 x 26.80 x 3.95, unit: mm)
  - JEDEC MO-300B compliant
- **Intelligent endurance design**
  - Built-in hardware ECC, enabling up to 40 bit correction per 1Kbyte sector
  - Global wear-leveling scheme together with dynamical block allocation to significantly increase the lifetime of a flash device and optimize the disk performance
  - Flash bad-block management
  - SMART Command
  - *Power Failure Management*
  - *ATA Secure Erase*
  - *Trim Command*
- **LED Indicators for Drive Behavior**
- **Thermal Sensor (optional)**
- **RoHS Compliant**
- **Capacity**
  - 1, 2, 4, 8, 16, 32GB
- **Low power consumption (typical)**
  - Supply voltage: 3.3 ± 5%V
  - Active mode: 330 mA
  - Idle mode: 100 mA
- **Endurance in Terabytes Written (TBW)**
  - 1 GB: 78 TBW
  - 2 GB: 154 TBW
  - 4 GB: 310 TBW
  - 8 GB: 620 TBW
  - 16 GB: 1231 TBW
  - 32 GB: 2868 TBW

---

## Table of Contents

1 Product Description .....	4
1.1 General Description.....	4
1.2 Capacity Specification.....	4
1.3 Performance Specification .....	5
1.4 Pin Assignments.....	5
2. Software Interface .....	7
2.1 Command Set.....	7
3. Flash Management .....	8
3.1 Error Correction/Detection.....	8
3.2 Wear Leveling .....	8
3.3 Power Failure Management.....	8
3.4 ATA Secure Erase .....	8
3.5 S.M.A.R.T. Technology .....	8
3.6 TRIM Command Support.....	8
3.7 SATA Power Management .....	9
4. Environmental Specifications .....	9
4.1 Environments .....	9
4.2 Mean Time Between Failures (MTBF) .....	9
4.3 Certification and Compliance.....	10
4.4 Endurance.....	10
5. Electrical Specification .....	11
5.1 Operating Voltage .....	11
5.2 Power Consumption .....	11
6. Physical Characteristics .....	12
6.1 Dimensions.....	12
7. Product Ordering Information.....	13
7.1 Product Code Designations .....	13
7.2 Valid Combinations.....	14
8. Revision History .....	15

## 1 Product Description

### 1.1 General Description

Fortasa's mini mSATA A is a high-performance, SATA interface, solid state drive (SSD) designed to replace a conventional SATA hard disk drive. mSATA supports standard SATA protocol and can be plugged into a standard mini PCIe connector commonly found in rugged laptops, military devices, thin clients, Point of Sale (POS) terminals, telecom, medical instruments, surveillance systems and industrial PCs. Complying with JEDEC MO-300 standard, the mSATA SSD is a widely adopted embedded storage with compact size and exceptional performance.

The mini mSATA A drive offers capacities of up to 128 gigabytes, providing full support for the SATA 6.0Gbit high-speed interface standard. It can operate at sustained access rates of up to 65 megabytes per second, which is much faster than other solid-state or traditional HDD SATA drives currently available on the market. **Manufactured using Industrial Temperature rated SLC NAND-flash, this SSD can work in highly demanding environment and withstand wide range of operating temperature from -40°C to +85°C.**

mini mSATA A offers high reliability global data wear-leveling scheme to allow uniform use of all storage blocks, increasing the lifetime of Flash media and optimizing drive performance. The mini mSATA A also offers Self-Monitoring Analysis and Reporting Technology (S.M.A.R.T.) feature monitors the drive accesses and provides the host with vital information about drive condition to schedule maintenance and service times.

### 1.2 Capacity Specification

Standard capacity specification of the mini mSATA A Flash Drive product are shown in Table 1-1. The table lists the specific capacity and the default numbers of heads, sectors and cylinders (CHS) for each product line.

**Table 1-1: Capacity specifications**

Capacity	Total Bytes	Cylinders	Heads	Sectors	Max LBA
2GB	2,011,226,112	15525	16	63	3,928,176
4GB	4,011,614,208	15525	16	63	7,835,184
8GB	8,012,390,400	15525	16	63	15,649,200
16GB	16,013,942,784	16383 <sup>1</sup>	16	63	31,277,232
32GB	32,017,047,552	16383 <sup>1</sup>	16	63	62,533,296

1. Cylinders, heads or sectors are not applicable for these capacities. Only LBA addressing applies.

*Please contact factory for any non-listed SATA Flash Drive capacity or custom CHS requirement.*

### 1.3 Performance Specification

Performances of the mini mSATA A Flash Drive are listed in Tables 1-2.

**Table 1-2:** Performance specifications

<b>Performance \ Capacity</b>	<b>2GB</b>	<b>4GB</b>	<b>8GB</b>	<b>16GB</b>	<b>32GB</b>
<b>Sustained read (MB/s)</b>	60	65	55	65	65
<b>Sustained write (MB/s)</b>	27	55	37	60	60
<b>Random Read IOPS (4K)</b>	11,000	15,000	12,000	14,000	15,000
<b>Random Write IOPS (4K)</b>	1,000	3,000	4,000	11,000	15,000

Note: Performance varies from flash configurations or host system settings.

### 1.4 Pin Assignments

Pin assignment of the mini mSATA A is shown in Figure 1-2 and described in Table 1-3.

**Figure 1-2:** mini mSATA A pin assignment



# mSATA mini Flash Drive

## FMS-MSMNxxxxX-xT



Pin	Assignment	Description	Pin	Assignment	Description
1	N/A	N/A	27	Ground	Return Current Path
2	3.3V	3.3V source	28	N/A	N/A
3	N/A	N/A	29	Ground	Return Current Path
4	Ground	Return Current Path	30	N/A	N/A
5	N/A	N/A	31	Rx-	SATA Differential
6	N/A	N/A	32	N/A	N/A
7	N/A	N/A	33	Rx+	SATA Differential
8	N/A	N/A	34	Ground	Return Current Path
9	Ground	Return Current Path	35	Ground	Return Current Path
10	N/A	N/A	36	Reserved	No Connect
11	N/A	N/A	37	Ground	Return Current Path
12	N/A	N/A	38	Reserved	No Connect
13	N/A	N/A	39	3.3V	3.3V source
14	N/A	N/A	40	Ground	Return Current Path
15	Ground	Return Current Path	41	3.3V	3.3V source
16	N/A	N/A	42	N/A	N/A
17	N/A	N/A	43	Ground	Return Current Path
18	Ground	Return Current Path	44	N/A	N/A
19	N/A	N/A	45	Reserved	N/A
20	N/A	N/A	46	N/A	N/A
21	Ground	Return Current Path	47	Reserved	N/A
22	N/A	N/A	48	N/A	N/A
23	Tx+	SATA Differential	49	DAS	Device Activity Signal
24	3.3V	3.3V source	50	Ground	Return Current Path
25	Tx-	SATA Differential	51	Presence Detection	Shall be pulled to GND by device
26	Ground	Return Current Path	52	3.3V	3.3V source

Table 1-3: Pin Assignment Description

## 2. Software Interface

### 2.1 Command Set

Table 2-1 summarizes the mini mSATA A command set.

**Table 2-1:** Command set

Command	Code	Command	Code
Check-Power-Mode	E5H	Recalibrate	10H
Execute-Drive-Diagnostic	90H	Security-Freeze-Lock	F5H
Flush-Cache	E7H	Security-Set-Password	F1H
Identify-Drive	ECH	Security-Unlock	F2H
Idle	E3H	Seek	7xH
Idle-Immediate	E1H	Set-Features	EFH
Initialize-Drive-Parameters	91H	SMART	B0H
Read DMA	C8H	Set-Multiple-Mode	C6H
Read DMA EXT	25H	Set-Sleep-Mode	E6H
Read FPDMA Queued	60H	Stand-By	E2H
Read Log DMA EXT	47H	Stand-By-Immediate	E0H
Read Log EXT	2FH	Write DMA	CAH
Read-Multiple	C4H	Write DMA EXT	35H
Read-Sector	20H or 21H	Write Log DMA EXT	57H
Read-Verify-Sectors	40H or 41H	Write FPDMA Queued	61H
Security-Disable-Password	F6H	Write Log EXT	3FH
Security-Erase-Prepare	F3H	Write-Multiple	C5H
Security-Erase-Unit	F4H	Write-Sector	30H or 31H

---

### 3. Flash Management

#### 3.1 Error Correction/Detection

The mini mSATA A implements a hardware BCH-based ECC scheme to achieve up to 40 bits of error in 1K byte page.

#### 3.2 Wear Leveling

All NAND flash devices are limited by a finite number of write cycles. Under a standard file system, frequent file table updates are mandatory. As a painful side effect of OS file overhead, some areas of flash address space wear out faster than others. As these certain sections get a substantially higher write occurrence the whole Flash Drive can wear out very quickly. This uneven wear would significantly reduce the lifetime of the whole device, even if majority of the Flash sectors are far from the write cycle limit. Fortasa's mini mSATA A Flash Drive products offer advanced data wear leveling which distributes Flash writes evenly across the SATA Flash Drive memory space. By utilizing this advanced wear leveling feature, the lifetime of the media can be significantly extended.

#### 3.3 Power Failure Management

The Low Power Detection on the Flash controller initiates cached data saving before the power supply to the device drops too low for operation. This feature prevents the device from system crash and ensures data integrity during an unexpected brownout. This feature makes sure that there are no catastrophic failures of the SATA Flash Drive due to system power glitches.

#### 3.4 ATA Secure Erase

Accomplished by the Secure Erase (SE) command, which is part of the ANSI standards that control disk drives, "ATA Secure Erase" is built into the disk drive itself and thus far less susceptible to malicious software attacks than external software utilities. Execution of this command amounts to electronic data shredding and causes the SSD to internally completely erase all possible user data. Aside from user data, all data erase counters and other internal controller information stored on the Flash media will be also permanently deleted. The erase process will not stop until it is completed. In case of power failure, the erase process will continue when the power is reapplied to the device.

#### 3.5 S.M.A.R.T. Technology

S.M.A.R.T. is an acronym for Self-Monitoring, Analysis and Reporting Technology, an open standard allowing disk drives to automatically monitor their own health and report potential problems. It protects the user from unscheduled downtime by monitoring and storing critical drive performance and calibration parameters. Ideally, this should allow taking proactive actions to prevent impending drive failure. Fortasa SMART Attribute IDs include Initial bad block count, Bad block count, Spare block count, Maximum erase count, Average erase count and Power cycle.

#### 3.6 TRIM Command Support

Over time the performance of SSD degrades as user continually writes and erases data. The ATA-TRIM command "formats" the SSD to optimize the drive performance. A TRIM enabled SSD running an OS with TRIM support will stay closer to its peak performance without much performance variance.



### 3.7 SATA Power Management

The mini mSATA A devices support the following SATA power saving modes:

- ACTIVE: PHY ready, full power, Tx & Rx operational
- PARTIAL: Reduces power, resumes in under 10  $\mu$ s (microseconds)
- SLUMBER: Reduces power, resumes in under 10 ms (milliseconds)
- HIPM: Host-Initiated Power Management
- DIPM: Device-Initiated Power Management
- AUTO-SLUMBER: Automatic transition from partial to slumber.

Note:

1. The behaviors of power management features depend on host/device settings.

## 4. Environmental Specifications

### 4.1 Environments

Environmental specification of the mini mSATA A Flash Drive series follows the MIL-STD-810F standard as shown in Table 4-1.

**Table 4-1:** Environmental specifications

Environment		Specification
Temperature	Operation	0°C to 70°C (Standard); -40°C to 85°C (Industrial)
	Storage	-40°C to 100°C
Vibration		Sine wave: 10~2000 Hz, 15G (X, Y, Z) Random: 10-2000 Hz, 7.7Grms (X, Y, Z)
Shock		Operating: 50 G, 11 ms Non-operating: 1500 G, 0.5 ms
Humidity		RH 90% under 40°C

### 4.2 Mean Time Between Failures (MTBF)

Mean Time Between Failures (MTBF) is predicted based on reliability data for the individual components in the mSATA drive. Based on provided component data, mini mSATA A Flash Drive is rated at more than 2,000,000 hours.

Notes about the MTBF:

The MTBF is predicated and calculated based on “Telcordia Technologies Special Report, SR-332, Issue 2” method.

---

### 4.3 Certification and Compliance

The mini mSATA A complies with the following standards:

- CE
- FCC
- RoHS
- MIL-STD-810F

### 4.4 Endurance

The endurance of a storage device is predicted by a JEDEC approved test methodology. The data, reported in TeraBytes Written, is based on several factors related to device architecture and product usage, such as the amount of data written into the drive, block management conditions, and daily workload for the drive. Please contact Sales to learn more about the TBW analysis and calculations.

Capacity	TBW
<b>2GB</b>	<b>154</b>
<b>4GB</b>	<b>310</b>
<b>8GB</b>	<b>620</b>
<b>16GB</b>	<b>1231</b>
<b>32GB</b>	<b>2868</b>

Notes:

- The measurement assumes the data written to the SSD for test is under a typical and constant rate.
- The measurement follows the standard metric: 1 TB (Terabyte) = 1000 GB.

## 5. Electrical Specification

### 5.1 Operating Voltage

**Caution: Absolute Maximum Stress Ratings** – Applied conditions greater than those listed under “Absolute Maximum Stress Ratings” may cause permanent damage to the device. This is a stress rating only and functional operation of the device at these conditions or conditions greater than those defined in the operational sections of this data sheet is not implied. Exposure to absolute maximum stress rating conditions may affect device reliability.

**Table 5-1:** Operating range

Range	Ambient Temperature	3.3V
Commercial	0°C to +70°C	3.3V ±5% (3.135 - 3.465 V)
Enhanced	-40°C to +85°C	

### 5.2 Power Consumption

Tables 5-2 lists the Mini mSATA A power consumption.

**Table 5-2** mini mSATA A power consumption (typical)

Performance \ Capacity	2GB	4GB	8GB	16GB	32GB
	<b>Active Mode (mW)</b>	230	270	220	250
<b>Idle Mode (mW)</b>	80	75	100	100	90

## 6. Physical Characteristics

### 6.1 Dimensions

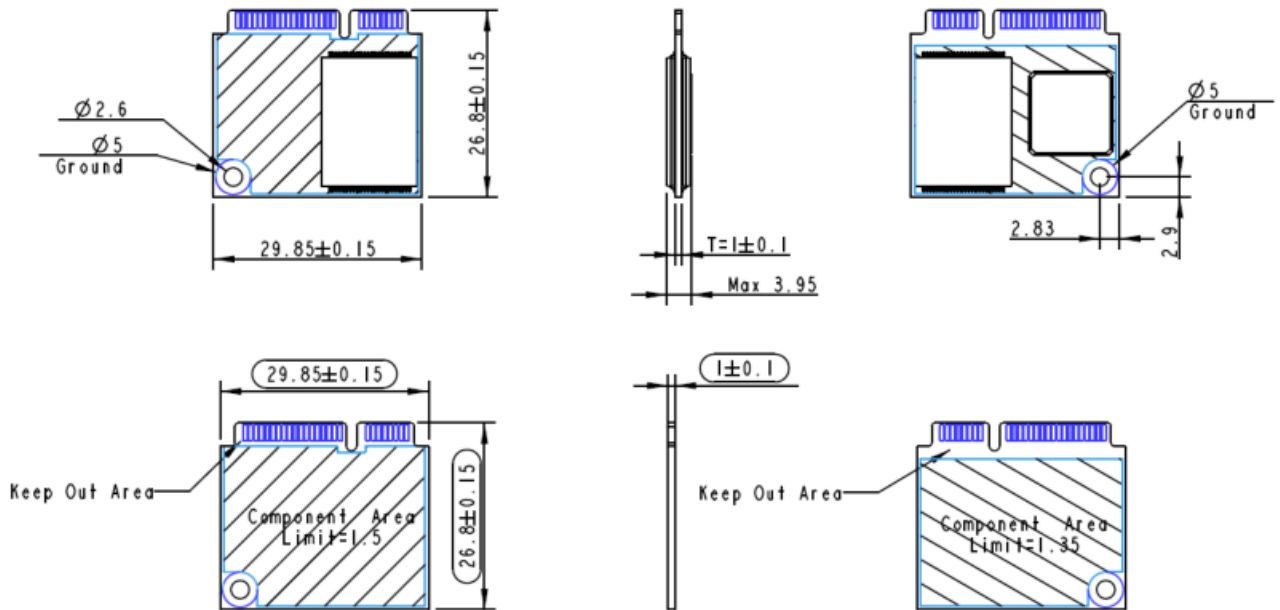

Units: mm  
Tolerance:  $\pm 0.2$

## 7. Product Ordering Information

### 7.1 Product Code Designations

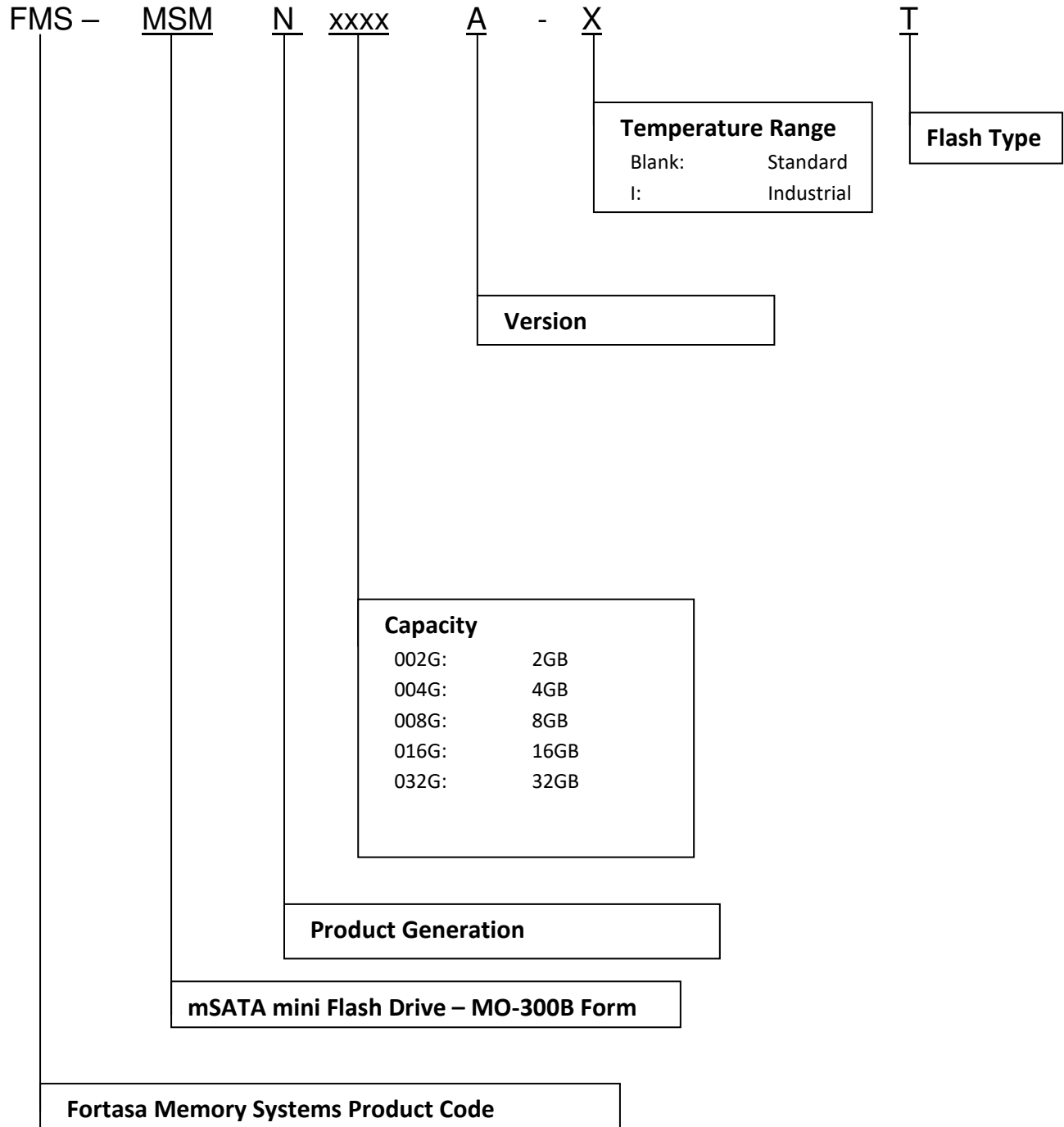

## 7.2 Valid Combinations

### mini mSATA A

Capacity	Standard Temperature	Industrial Temperature
1GB	FMS-MSMN001GA-T	FMS-MSMN001GA-IT
2GB	FMS-MSMN002GA-T	FMS-MSMN002GA-IT
4GB	FMS-MSMN004GA-T	FMS-MSMN004GA-IT
8GB	FMS-MSMN008GA-T	FMS-MSMN008GA-IT
16GB	FMS-MSMN016GA-T	FMS-MSMN016GA-IT
32GB	FMS-MSMN032GA-T	FMS-MSMN032GA-IT

**Note:** Valid combinations are those products in mass production or will be in mass production. Consult your Fortasa sales representative to confirm availability of valid combinations and to determine availability of new product combinations

---

## 8. Revision History

Revision	Date	Description	Comments
1.0	1/11/2017	Initial Release	
1.1	2/8/2017	Updated mechanical specifications	
1.2	2/16/2017	Added Thermal Sensor as an optional feature on Features page	
1.3	3/30/2017	Updated product ordering information	
1.4	3/31/2017	Modified form factor on Features page and 1.1 Introduction	
1.5	9/6/2017	Added 2-4GB support	